

EPSON

COLOR INK-JET PRINTER

EPSON Stylus Color 600

SERVICE MANUAL

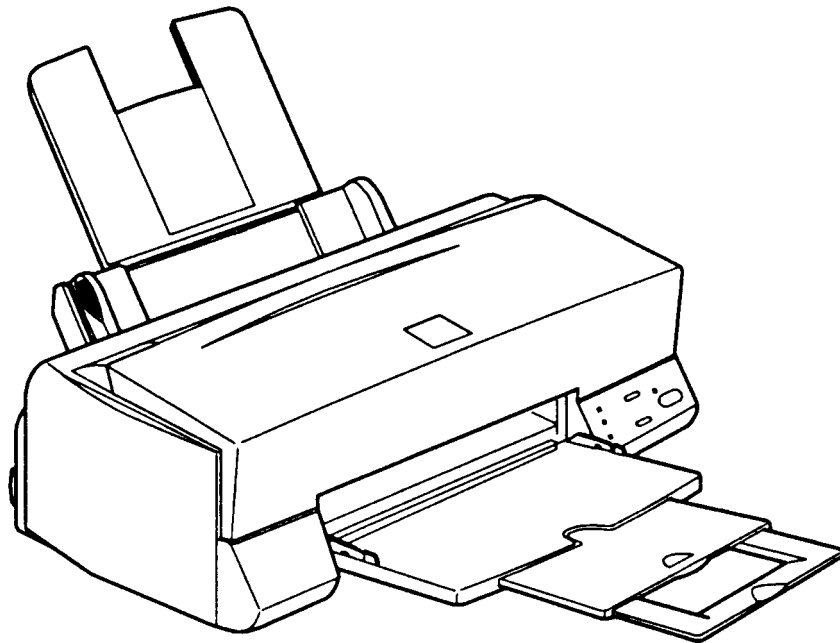

SEIKO EPSON CORPORATION

4007367

NOTICE

- All rights reserved. Reproduction of any part of this manual in any form whatsoever without SEIKO EPSON's express written permission is forbidden.
- The contents of this manual are subjects to change without notice.
- All efforts have been made to ensure the accuracy of the contents of this manual. However, should any errors be detected, SEIKO EPSON would greatly appreciate being informed of them.
- The above notwithstanding SEIKO EPSON can assume no responsibility for any errors in this manual or the consequences thereof.

EPSON is a registered trademark of SEIKO EPSON CORPORATION.

General Notice:

Other product names used herein are for identification purposes only and may be trademarks or registered trademarks of their respective companies.

*Copyright © 1997 by SEIKO EPSON CORPORATION
Nagano, Japan*

PRECAUTIONS

Precautionary notations throughout the text are categorized relative to 1) personal injury and 2) damage to equipment.

WARNING Signals a precaution which, if ignored, could result in serious or fatal personal injury. Great caution should be exercised in performing procedures preceded by WARNING Headings.

CAUTION Signals a precaution which, if ignored, could result in damage to equipment.

The precautionary measures itemized below should always be observed when performing repair/maintenance procedures.

WARNING

1. ALWAYS DISCONNECT THE PRODUCT FROM BOTH THE POWER SOURCE AND PERIPHERAL DEVICES PERFORMING ANY MAINTENANCE OR REPAIR PROCEDURES.
2. NO WORK SHOULD BE PERFORMED ON THE UNIT BY PERSONS UNFAMILIAR WITH BASIC SAFETY MEASURES AS DICTATED FOR ALL ELECTRONICS TECHNICIANS IN THEIR LINE OF WORK.
3. WHEN PERFORMING TESTING AS DICTATED WITHIN THIS MANUAL. DO NOT CONNECT THE UNIT TO A POWER SOURCE UNTIL INSTRUCTED TO DO SO. WHEN THE POWER SUPPLY CABLE MUST BE CONNECTED, USE EXTREME CAUTION IN WORKING ON POWER SUPPLY AND OTHER ELECTRONIC COMPONENTS.

CAUTION

1. REPAIRS ON EPSON PRODUCT SHOULD BE PERFORMED ONLY BY EPSON CERTIFIED REPAIR TECHNICIAN.
2. MAKE CERTAIN THAT THE SOURCE VOLTAGE IS THE SAME AS THE RATED VOLTAGE, LISTED ON THE SERIAL NUMBER/RATING PLATE. IF THE EPSON PRODUCT HAS A PRIMARY AC RATING DIFFERENT FROM AVAILABLE POWER SOURCE, DO NOT CONNECT IT TO THE POWER SOURCE.
3. ALWAYS VERIFY THAT THE EPSON PRODUCT HAS BEEN DISCONNECTED FROM THE POWER SOURCE BEFORE REMOVING OR REPLACING PRINTED CIRCUIT BOARDS AND/OR INDIVIDUAL CHIPS.
4. IN ORDER TO PROTECT SENSITIVE MICROPROCESSORS AND CIRCUITRY, USE STATIC DISCHARGE EQUIPMENT, SUCH AS ANTI-STATIC WRIST STRAPS, WHEN ACCESSING INTERNAL COMPONENTS.
5. REPLACE MALFUNCTIONING COMPONENTS ONLY WITH THOSE COMPONENTS BY THE MANUFACTURE; INTRODUCTION OF SECOND-SOURCE ICs OR OTHER NONAPPROVED COMPONENTS MAY DAMAGE THE PRODUCT AND VOID ANY APPLICABLE EPSON WARRANTY.

PREFACE

This manual describes functions, theory of electrical and mechanical operations, maintenance, and repair of EPSON Stylus Color 600.

The instructions and procedures included herein are intended for the experience repair technician, and attention should be given to die precautions on the preceding page. The Chapters are organized as follows:

CHAPTER 1. GENERAL DESCRIPTION

Provides a general product overview, lists specifications, and illustrates the main components of the printer.

CHAPTER 2. OPERATING PRINCIPLES

Describes the theory of printer operation.

CHAPTER 3. DISASSEMBLY AND ASSEMBLY

Includes a step-by-step guide for product disassembly and assembly.

CHAPTER 4. ADJUSTMENT

Includes a step-by-step guide for adjustment.

CHAPTER 5. TROUBLESHOOTING

Provides EPSON-approved techniques for troubleshooting.

CHAPTER 6. MAINTENANCE

Describes preventive maintenance techniques and lists lubricants and adhesives required to service the equipment.

APPENDIX

Describes connector pin assignments, circuit diagrams, circuit board component layout and exploded diagram.

The contents of this manual are subject to change without notice.

REVISION SHEET

Revision	Issued Data	Contents
Rev. A		First issue

TABLE OF CONTENTS

CHAPTER 1.	GENERAL DESCRIPTION
CHAPTER 2.	OPERATING PRINCIPLES
CHAPTER 3.	DISASSEMBLY AND ASSEMBLY
CHAPTER 4.	ADJUSTMENT
CHAPTER 5.	TROUBLESHOOTING
CHAPTER 6.	MAINTENANCE
APPENDIX	

Chapter 1

Product Descriptions

1.1 Features	1-1
1.2 Specifications	1-2
1.2.1 Printing Specification	1-2
1.2.2 Paper Specification	1-5
1.2.2.1 Cut Sheet	1-5
1.2.2.2 Transparency Film / Glossy Paper	1-5
1.2.2.3 Envelope	1-5
1.2.2.4 Index Card.....	1-5
1.2.3 Adjust Lever Settings (PG adjust lever)	1-6
1.2.4 Printable Area	1-7
1.2.4.1 Cut Sheet	1-7
1.2.4.2 Envelope	1-8
1.2.5 Environmental Condition	1-9
1.2.6 Ink Cartridge Specifications	1-10
1.2.6.1 Black Ink Cartridge	1-10
1.2.6.2 Color Ink Cartridge	1-11
1.2.7 Physical Specification	1-12
1.2.8 Electric Specification	1-13
1.2.9 Reliability	1-13
1.2.10 Safety Approvals	1-13
1.2.11 Acoustic Noise	1-13
1.2.12 CE Marking	1-13
1.2.13 Printer Language and Emulation	1-14
1.3 Interface	1-16
1.3.1 Parallel Interface (Forward Channel)	1-16
1.3.2 Parallel Interface (Reverse Channel)	1-17
1.3.2.1 Prevention Hosts from Data Transfer time-out.....	1-19
1.3.3 Serial Interface	1-20
1.4 Control Panel	1-21
1.4.1 Indicators	1-21
1.4.2 Panel Functions	1-22
1.4.3 Printer Condition and Panel Status	1-23
1.5 Error Status	1-24
1.5.1 Ink Out	1-24
1.5.2 Paper Out	1-24
1.5.3 Paper Jam	1-24
1.5.4 No Ink-Cartridge Error	1-25
1.5.5 Maintenance Request	1-25
1.5.6 Fatal Errors	1-25
1.6 Printer Initialization	1-26
1.6.1 Initialization Settings	1-26
1.7 Main Components	1-27
1.7.1 Printer Mechanism	1-27
1.7.2 C200 MAIN Board	1-28
1.7.3 C206 PSB/PSE Board	1-29
1.7.4 C206 PNL Board	1-29

1.1 Features

EPSON Stylus Color 600 is designed for low price for that high performance. The major printer features are;

- High color print quality
 - 1440(H) x 720(V) dpi printing
 - Standard 4 color printing (CMY+Bk)
 - Traditional and New Microwave control to eliminate banding
- Built-in auto sheet feeder
 - Holds 100 cut-sheets (64g/±u)
 - Holds 10 envelopes
 - Holds 10 transparency films
 - Holds 65 special papers
- High-speed print
 - 200cps (at LQ/10CPI; No-Draft mode)
 - By driving the printhead at frequency; 1.44KHz, printing speed is twice faster than Stylus Color.
- Compact size
 - Non-operating : 429mm(W) x 275mm(D) x 168mm(H)
 - Operating : 429mm(W) x 613mm(D) x 309mm(H)
 - Weight : 5.2Kg (without cartridge)
- Acoustic noise
 - Approximately 47dB(A)
- Two built-in standard I/F
 - Bi-directional Parallel I/F (IEEE-1284 level 1 device)
 - Serial I/F (Macintosh-compatible / up to 900Kbps)

The table below shows consumable for EPSON Stylus Color 600.

Table 1-1 Available Consumable

Item	Code	Remark
Black Ink Cartridge	S020093	Color: Black
Color Ink Cartridge	S020089	Color: Cyan/Magenta/Yellow
EPSON 360 dpi Ink Jet Paper	S041025	Size: A4(200 sheets)
EPSON 360 dpi Ink Jet Paper	S041059	Size: A4(100 sheets)
EPSON 360 dpi Ink Jet Paper	Product number	Size: Letter(100 sheets)
Photo Quality Ink Jet Paper	S041026	Size: A4(200 sheets)
Photo Quality Ink Jet Paper	S041061	Size: A4(100 sheets)
Photo Quality Ink Jet Paper	S041062	Size: Letter
Photo Quality Ink Jet Paper	S041067	Size: Legal
Photo Quality Glossy Paper(New Release)	S041126	Size: A4
Photo Quality Glossy Paper(New Release)	S041124	Size: Letter
Photo Quality Glossy Film	S041071	Size: A4
Photo Quality Glossy Film	Product Numbers	Size: Letter
Photo Quality Glossy Film	S041107	Size: A6
Ink Jet Transparencies	S041063	Size: A4
Ink Jet Transparencies	Product Numbers	Size: Letter
Photo Quality Ink Jet Card	S041054	Size: A6
Photo Quality Ink Jet Card	S041121	Size: 5 x 8 inches
Photo Quality Ink Jet Card	S041122	Size: 10 x 8 inches
Photo Quality Self Adhesive Sheet	S041106	Size: A4

1.2 Specifications

This section describes the product specifications for EPSON Stylus Color 600.

1.2.1 Printing Specification

- Print method
 - On-demand color ink jet printing
- Nozzle configuration
 - Black: 64 nozzles (32 nozzles x2 staggered / Nozzle pitch = 180dpi/vertical)
 - Color: 32 nozzles (per color (CMY) / Nozzle pitch = 90dpi/vertical)
- Print Direction
 - Bi-directional printing with logical seeking for text and graphics
- Print Buffer: 32KBytes
- Print speed and Printable Columns

Table 1-2 Print Speed (Text Mode)

Character Pitch	Printable Column	Draft Speed (CPS)	LQ Speed (CPS)
10 CPI (Pica)	80	400	200
12 CPI (Elite)	96	480	240
15 CPI	120	600	300
17 CPI (Pica Condensed)	137	684	342
20 CPI (Elite Condensed)	160	800	400

Table 1-3 Print Speed (Raster Graphics Mode)

Horizontal Resolution	Printable Area	Available Dot	CR Speed (IPS)
180 dpi	8.26 inch	1488	20
360 dpi	8.26 inch	2976	20
720 dpi	8.26 inch	5952	20

- Nozzle arrangement: See figure below.

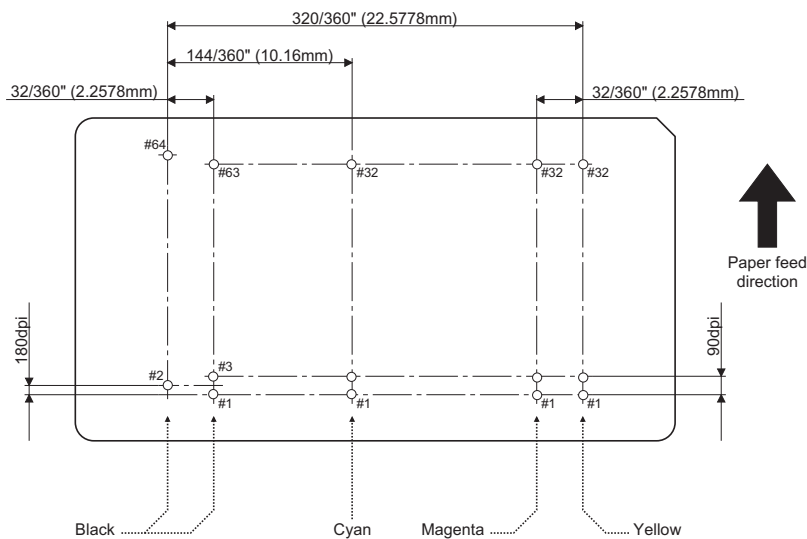

*Viewed from the back of the head

Figure 1-1. Nozzle Layout

- ❑ Paper Feeding Method
 - Friction feed with built in ASF (Auto Sheet Feeder)
- ❑ Line Spacing
 - 1/6 inch or programmable at 1/360 inch
- ❑ Paper Path
 - Top entry (from ASF) only
- ❑ Feeding Speed
 - 66.6 ms (at 1/6 inch line-feed)
 - 3.0 inch/sec (76.2 mm/sec / at continuous-feed)
- ❑ ASF Capacity
 - Size :Index card to Legal
 - Thickness *1 :Less than 8mm
 - Paper capacity *2 :Normal cut sheets =100 sheets (64g/m²)
 - :Envelops =10
 - :Coated papers (360dpi) =65
 - :Coated papers (720dpi) =65
 - :Glossy papers *3 *4 =30
 - :Transparency films *4 =30
 - :Index cards *4 =30

Notes) *1: Total thickness of paper stack on the ASF.

*2: Those numbers above should be considered as reference. The actual paper accumulation should be considered first.

*3: Only when the top margin is set for 30mm with A4/Letter size paper, otherwise only one sheet can be set at a time.

*4: Specified paper must be set at the bottom of stack to ensure proper feeding operation:

- Normal paper =Glossy paper, Transparency film
- Card Board =Index card
(The one packed with the index card package)

EPSON Stylus Color 600

- ❑ Control Code
 - ESC/P2 and expanded raster graphics code
 - EPSON Remote command
- ❑ Character Tables

Legal and 14 international character sets

 - Standard version: 11 character tables (See Table 1-4 for details)
 - NLSP version: 19 character tables (See Table 1-4 for details)
- ❑ Typeface *1
 - Bit map LQ font:

EPSON Roman	(10/12/15 CPI, Proportional)
EPSON Sans Serif	(10/12/15 CPI, Proportional)
EPSON Courier	(10/12/15 CPI)
EPSON Prestige	(10/12/15 CPI)
EPSON Script	(10/12/15 CPI)
 - Scaleable font:

EPSON Roman	(10.5 pt, 8 to 32 pt (every 2 pt))
EPSON Sans Serif	(10.5 pt, 8 to 32 pt (every 2 pt))
EPSON Roman T	(10.5 pt, 8 to 32 pt (every 2 pt))
EPSON Sans Serif H	(10.5 pt, 8 to 32 pt)

Note) *1: Each typeface has four different font style; Normal, Bold, Italic and Bold-Italic.

Table 1-4 Character Table and Typeface

Version	Character Table	Bit-map Font	Scaleable Font	
Common		EPSON - ; Roman Sans Serif Courier Prestige Script	EPSON - ; Roman Sans Serif	EPSON - ; Roman T Sans Serif H
Standard	Italic PC437 (US / Standard Europe) PC850 (Multilingual) PC860 (Portuguese) PC861 (Icelandic) PC863 (Canadian-French) PC865 (Nordic) BRASCII Abicom Roman 8 ISO Latin 1	Supported	Supported	Supported
NLSP	Italic PC437 (US / Standard Europe) PC850 (Multilingual)	Supported	Supported	Supported
	PC437 Greek PC852 (East Europe) PC853 (Turkish) PC855 (Cyrillic) PC857 (Turkish) PC866 (Russian) PC869 (Greek) MAZOWIA (Poland) Code MJK (CSFR) ISO 8859-7 (Latin/Greek) ISO Latin 1T (Turkish) Bulgaria (Bulgaria) PC774 Estonia ISO 8859-2 (ISO Latin 2) PC866 LAT	Supported	Supported	Not Supported

1.2.2 Paper Specification

This section describes the types of paper that can be used in this printer.

1.2.2.1 Cut Sheet

[Size]	:A4	[Width 210mm (8.3") x Length 297mm (11.7")]
	:Letter	[Width 216mm (8.5") x Length 279mm (11.0")]
	:B5	[Width 182mm (7.2") x Length 257mm (10.1")]
	:Legal	[Width 216mm (8.5") x Length 356mm (14.0")]
	:Half Letter	[Width 139.7mm (5.5") x Length 215.9mm (8.5")]
	:Exclusive	[Width 190.5mm (7.5") x Length 254mm (10")]

[Thickness] :0.08mm (0.003") - 0.11mm (0.004")

[Weight] :64g/m² (17lb.) - 90g/m² (24lb.)

[Quality] :Exclusive paper, Bond paper, PPC

1.2.2.2 Transparency Film / Glossy Paper

[Size]	:A4	[Width 210mm (8.3") x Length 297mm (11.7")]
	:Letter	[Width 216mm (8.5") x Length 279mm (11.0")]
	:A6	[Width 105mm (4.1") x Length 148mm (5.8")]

[Thickness] :0.13mm (0.005") - 0.15mm (0.006")

:0.17mm (0.007") - 0.18mm (0.007") for glossy paper

Note) Transparency printing is only available at normal temperature.

1.2.2.3 Envelope

[Size]	: No.10	[Width 241mm (9 1/2") x Length 104.8mm (4 1/8")]
	: DL	[Width 220mm (8.7") x Length 110mm (4.3")]
	: C6	[Width 162mm (6.4") x Length 114mm (4.5")]

[Thickness] : 0.16mm (0.006") - 0.43mm (0.017")

[Weight] : 45g/m² (12lb.) - 75g/m² (20lb.)

[Quality] : Bond paper, Plain paper, Air mail

- Note)*
1. Envelop printing is only available at normal temperature.
 2. Keep the longer side of the envelope horizontally at setting.

1.2.2.4 Index Card

[Size]	:A6 Index card	[Width 105mm (4.1") x Length 148mm (5.8")]
	:5x8" Index card	[Width 127mm (5.0") x Length 203mm (8.0")]
	:10x8" Index card	[Width 127mm (5.0") x Length 203mm (8.0")]

[Thickness] :Less than 0.23mm(0.0091")

[Weight] :188g/m²

- Note)*
1. No curled, wrinkled, scuffing or torn paper be used.
 2. Set the lever to the proper position according to the paper type you print. (Refer to section 1.2.3 for details)
 3. Printing should be performed at room temperature in spite of the paper types.

1.2.3 Adjust Lever Settings (PG adjust lever)

The adjust lever located on the right side (blue knob) under the printer cover needs to be set to the proper position according to the paper you print (Refer to the table below). Also, if there is any dirt caused by friction on the wavy or wrinkled paper, this can be prevented by changing the lever position to rear position (marked with "+") in spite of paper types.

Table 1-5. Adjust Lever Settings

Paper	Lever position	PG adjustment value
Normal paper, Coated paper Transparency film Label	Front	0 mm (1.1mm between head and platen)
Envelopes	Rear	0.9 mm (2.0mm between head and platen)

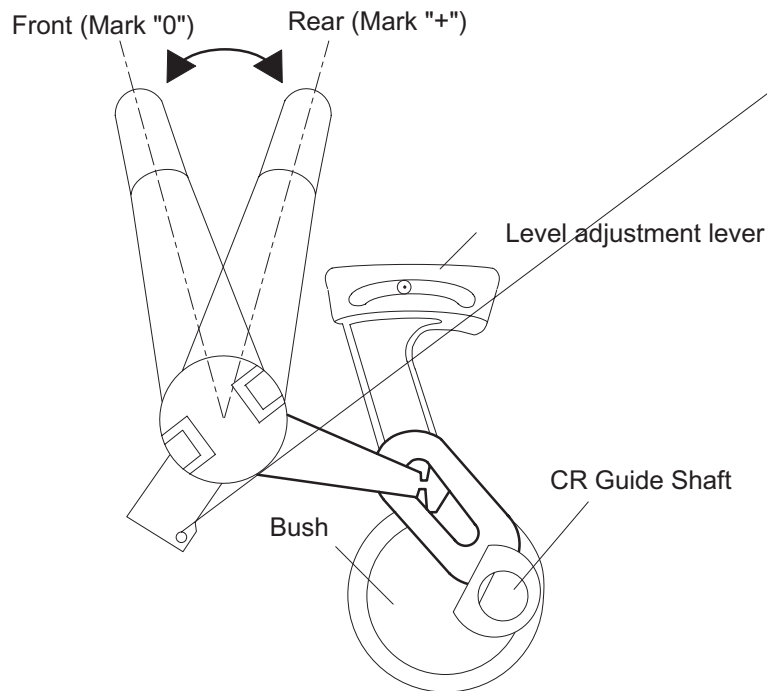

Figure 1-2. Adjust Lever Settings

1.2.4 Printable Area

1.2.4.1 Cut Sheet

Following tables show printable areas at Character mode and Raster Graphics mode.

Table 1-6. Character Table

Paper size	PW (Paper width) (typ.)	PL (Paper Length) (typ.)	LM (Left margin) (min.)	RM (Right margin) (min.)	TM (Top margin) (min.)	BM (Bottom margin) (min.)
A4	210mm(8.3")	297mm(11.7")	3mm(0.12")	3mm(0.12")	3mm(0.12")	14mm(0.54")
Letter	216mm(8.5")	279mm(11.0")	3mm(0.12")	9mm(0.35")	3mm(0.12")	14mm(0.54")
B5	182mm(7.2")	257mm(10.1")	3mm(0.12")	3mm(0.12")	3mm(0.12")	14mm(0.54")
Legal	216mm(8.5")	356mm(14.0")	3mm(0.12")	9mm(0.35")	3mm(0.12")	14mm(0.54")
Statement	139.7mm(5.5")	215.9mm(8.5")	3mm(0.12")	3mm(0.12")	3mm(0.12")	14mm(0.54")
Executive	190.5mm(7.5")	254mm(10")	3mm(0.12")	3mm(0.12")	3mm(0.12")	14mm(0.54")

Table 1-7. Raster Graphics Mode

Paper size	PW (Paper width) (typ.)	PL (Paper Length) (typ.)	LM (Left margin) (min.)	RM (Right margin) (min.)	TM (Top margin) (min.)	BM (Bottom margin) (min.)
A4	210mm(8.3")	297mm(11.7")	3mm(0.12")	3mm(0.12")	3mm(0.12")	14mm(0.54")
Letter	216mm(8.5")	279mm(11.0")	3mm(0.12")	3mm(0.12")	3mm(0.12")	14mm(0.54")
B5	182mm(7.2")	257mm(10.1")	3mm(0.12")	3mm(0.12")	3mm(0.12")	14mm(0.54")
Legal	216mm(8.5")	356mm(14.0")	3mm(0.12")	3mm(0.12")	3mm(0.12")	14mm(0.54")
Statement	139.7mm(5.5")	215.9mm(8.5")	3mm(0.12")	3mm(0.12")	3mm(0.12")	14mm(0.54")
Executive	190.5mm(7.5")	254mm(10")	3mm(0.12")	3mm(0.12")	3mm(0.12")	14mm(0.54")

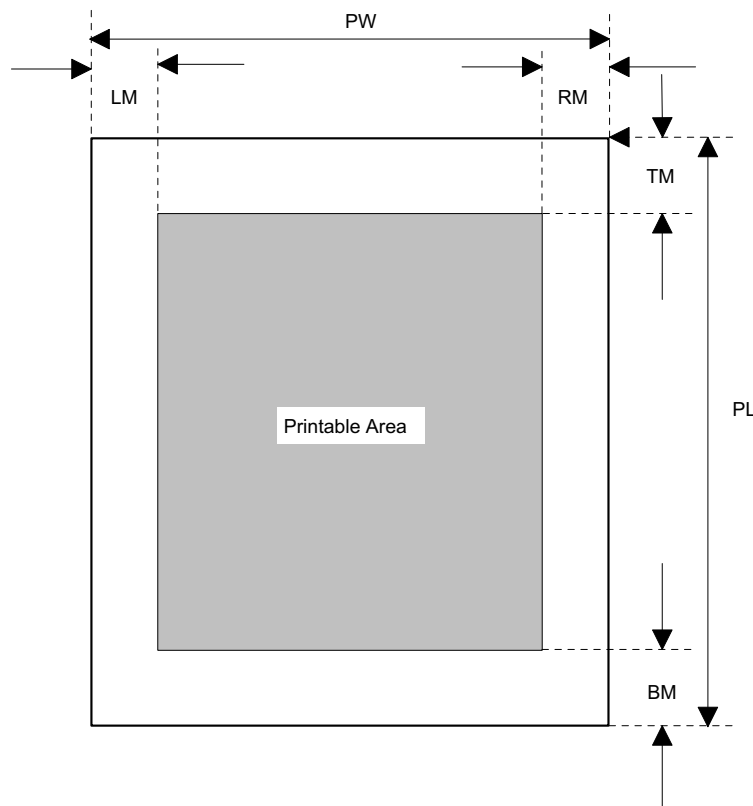

Figure 1-3. Printing Area for Cut Sheet

1.2.4.2 Envelope

The table and figure below show the printable area for envelopes.

Table 1-8. Envelope

Paper Size	LM (Left Margin) (min.)	RM (Right Margin) (min.)	TM (Top Margin) (min.)	BM (Bottom Margin) (min.)
#10	3mm (0.12")	28mm (1.10")	3mm (0.12")	14mm (0.55")
DL	3mm (0.12")	7mm (0.28")	3mm (0.12")	14mm (0.55")
C6	3mm (0.12")	3mm (0.12")	3mm (0.12")	14mm (0.55")

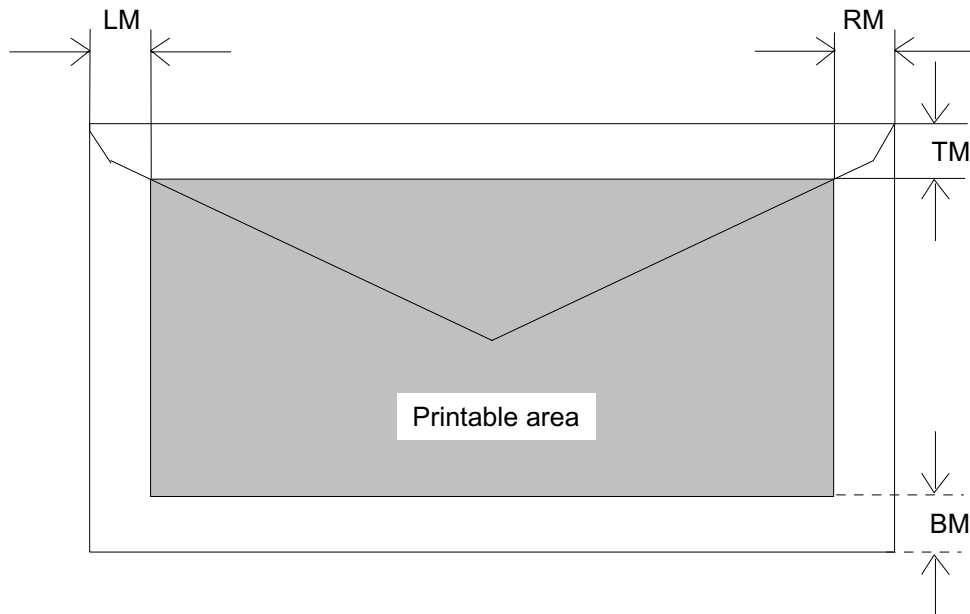

Figure 1-4. Printing Area for Envelope

1.2.5 Environmental Condition

- Temperature
 - Operating :10 - 35•• (Refer to the figure below for condition)
 - Non-operating :-20 - 60•• (with shipment container)

Note) Storage should be within one month at 40°C and 120 hours at 60°C.

- Humidity
 - Operating :20% - 80% RH
(without condensation. Refer to the figure below for condition)
 - Non-operating :5% - 85% RH
(without condensation and with shipment container)

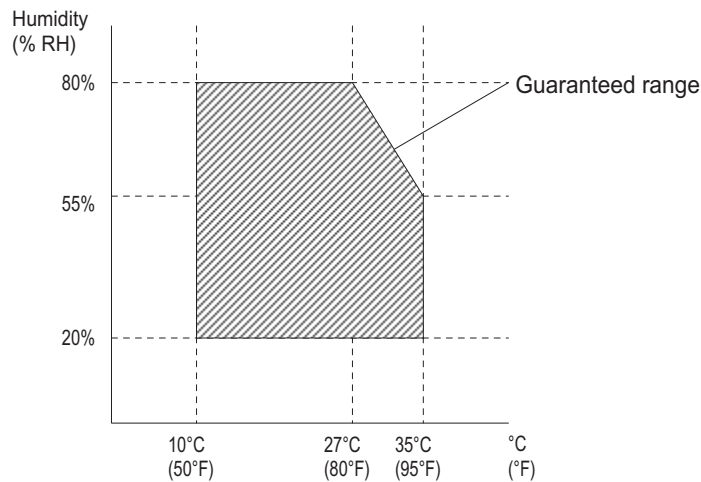

Figure 1-5. Temperature/Humidity of Range

- Resistance to shock
 - Operating :1G, within 1 ms (X,Y,Z directions)
 - Non-operating :2G, within 2 ms (X,Y,Z directions/with shipment container)
- Resistance to vibration
 - Operating :0.15G, 10•`55Hz (X,Y,Z directions)
 - Non-operating :0.50G, 10•`55Hz (X,Y,Z directions/with shipment container)

- Note)
1. During non-operating, make sure that the head is capped.
 2. During the transport, make sure that the head is capped and ink cartridge is installed to the printer.
 3. If the head is not capped at the power-off state, turn the power on with the ink cartridge installed and turn off the power after confirming that the head is correctly capped.
 4. Ink will be frozen under -4°C environment, however it will be useable after placing it more than 3 hours at 25°C.

1.2.6 Ink Cartridge Specifications

1.2.6.1 Black Ink Cartridge

Table 1-9. Black Ink Cartridge Specifications

Item	Specifications
Type	Black Ink Cartridge (Code: S020093)
Color	Black
Print capacity	540 pages / A4 (ISO/IE10561 Letter Pattern at 360 dpi)
Validity	2 years (sealed in package) / 6months(out of package)
Environmental conditions	<input type="checkbox"/> Temperature <ul style="list-style-type: none"> ■ Storage : -20 - 40°C (within a month at 40°C) ■ Packing storage : -30 - 40°C (within a month at 40°C) ■ Transit : -30 - 60°C (within 120 hours at 60°C and within a month at 40••) <input type="checkbox"/> Humidity <ul style="list-style-type: none"> ■ 5% - 85% (without condensation) <input type="checkbox"/> Resistance to vibration <ul style="list-style-type: none"> ■ Sealed in package : 5 - 55Hz ■ Acceleration : Less than 29.4m/s (3G) ■ Direction : X, Y, Z direction ■ Time : 1 hour <input type="checkbox"/> Drop <ul style="list-style-type: none"> ■ Sealed in package: <ul style="list-style-type: none"> <input type="checkbox"/> Dropping height : Less than 0.80m <input type="checkbox"/> Direction : Drop the package facing the bottom, sides and one edge down. ■ Out of package: <ul style="list-style-type: none"> <input type="checkbox"/> Dropping height : Less than 1.50m <input type="checkbox"/> Frequency : Once
Dimension	19.8mm(W) x 52.7(D) x 38.5mm(H)
Weight	<ul style="list-style-type: none"> ■ Total ink cartridge : 54g ■ Total ink : 16.4• } 0.5g (Amount in the ink cartridge) ■ Consumable ink : More than 12.1g(Useable ink quantity until ink ends)

- Note) 1. Ink cartridge can not re-fill, only ink cartridge is prepared for article of consumable.
 2. Do not use the ink cartridge which is passed away the ink life.
 3. Ink will be frozen under -4••environment, however it will be usual after placing it more than 3 hours at room temperature.

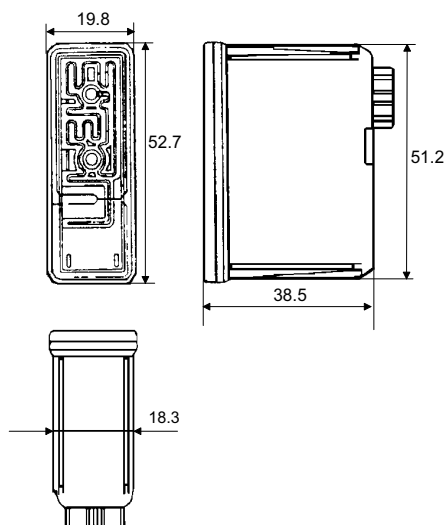

Figure 1-6. Ink Cartridge (Black)

1.2.6.2 Color Ink Cartridge

Table 1-10. Color Ink Cartridge Specification

Item	Specifications
Type	Color Ink Cartridge(Code: S020089)
Color	Magenta/Cyan/Yellow
Print capacity	300 pages / A4 (360 dpi, 5% duty each color)
Validity	2 years (sealed in package) / 6months(out of package)
Environmental conditions	<input type="checkbox"/> Temperature <ul style="list-style-type: none"> ■ Storage : -20•• - 40•• (within a month at 40••) ■ Packing storage : -30•• - 40•• (within a month at 40••) ■ Transit : -30•• - 60•• (within 120 hours at 60•• and within a month at 40••) <input type="checkbox"/> Humidity <ul style="list-style-type: none"> ■ 5% - 85% (without condensation) <input type="checkbox"/> Resistance to vibration <ul style="list-style-type: none"> ■ Sealed in package : 5 - 55Hz ■ Acceleration : Less than 29.4m/s (3G) ■ Direction : X, Y, Z direction ■ Time : 1 hour <input type="checkbox"/> Drop <ul style="list-style-type: none"> ■ Sealed in package : <ul style="list-style-type: none"> <input type="checkbox"/> Dropping height : Less than 0.80m <input type="checkbox"/> Direction : Drop the package facing the bottom, sides and one edge down. ■ Out of package: <ul style="list-style-type: none"> <input type="checkbox"/> Dropping height : Less than 1.50m <input type="checkbox"/> Frequency : Once
Dimension	42.9mm(W) x 52.7(D) x 38.5mm(H)
Weight	<ul style="list-style-type: none"> ■ Total ink cartridge : 68g ■ Total ink : 13.3• } 0.5g (Amount in the ink cartridge) ■ Consumable ink : More than 10.1g/each color (Useable ink quantity until ink ends)

- Note)
1. Ink cartridge can not re-fill, only ink cartridge is prepared for article of consumable.
 2. Do not use the ink cartridge which is passed away the ink life.
 3. Ink will be frozen under -4•• environment, however it will be usual after placing it more than 3 hours at room temperature.

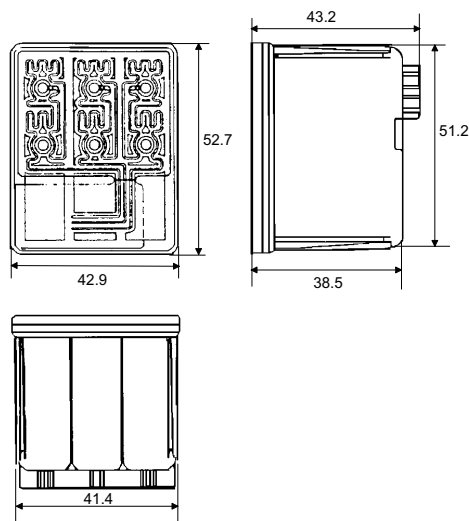

Figure 1-7. Ink Cartridge (Color)

1.2.7 Physical Specification

[Dimension] :429mm(W) x 234mm(D) x 162mm(H)
:429mm(W) x 695mm(D) x 309mm(H) with extended stacker and paper support.

[Weight] :5.2Kg

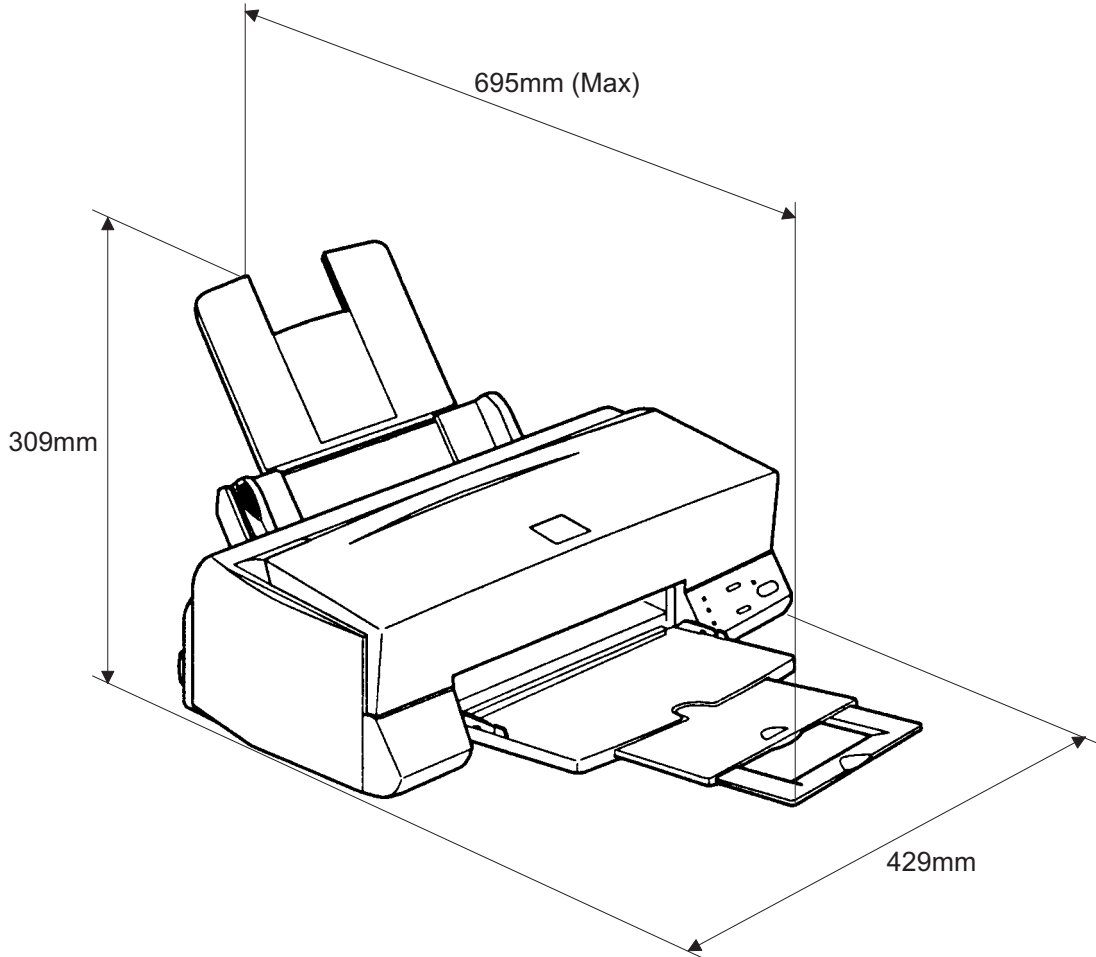

Figure 1-8. Dimension

1.2.8 Electric Specification

- [120V] Version
 - [Rated voltage] :AC120V
 - [Input voltage range] :AC103.5 - 132V
 - [Rated frequency range] :50 - 60Hz
 - [Input frequency range] :49.5 ~ 60.5Hz
 - [Rated current] :0.4A(Max. 0.5A)
 - [Power consumption] :Approx.15W(ISO/IEC 10561 Letter pattern)
(Energy Star compliant)
 - [Insulation Resistance] :10M ohms min.(between AC line and chassis, DC500V)
 - [Dielectric strength] :AC1000 V rms. 1 minute or AC1200Vrms. 1 second
(between AC line and chassis)

- [220 ~ 240V] Version
 - [Rated voltage] :AC220V - 240V
 - [Input voltage range] :AC198 - 264V
 - [Rated frequency range] :50 - 60Hz
 - [Input frequency range] :49.5 - 60.5Hz
 - [Rated current] :0.2 A(Max. 0.3A)
 - [Power consumption] :Approx.15W(ISO/IEC 10561 Letter pattern)
(Energy Star compliant)
 - [Insulation Resistance] :10M ohms min.(between AC line and chassis, DC500V)
 - [Dielectric strength] :AC1500 V rms. 1 minute (between AC line and chassis)

1.2.9 Reliability

- Total print volume :10,000 pages(A4, letter)
- Print head life :2000 million dots/nozzle

1.2.10 Safety Approvals

[120V version]

- Safety standard :UL1950 with D3
:CSA22.2 No.950 with D3
- EMC :FCC part 15 subpart B class B
:CSA C108.8 class B

[220 ~ 240V]

- Safety standard :EN 60950(VDE and NEMKO)
- EMC :EN55022(CISPR Pub.22) class B
:AS/NZS 3548 class B

1.2.11 Acoustic Noise

- Noise Level :Approx.45 dB(A) (According to ISO 7779)

1.2.12 CE Marking

[220-240V version]

- Low voltage Directive 73/23/EEC :EN60950
- EMC Directive 89/336/EEC :EN55022 Class B
:EN61000-3-2
:EN61000-3-3
:EN50082-1
:IEC801-2
:IEC801-3
:IEC801-4

1.2.13 Printer Language and Emulation

- Printer Language :ESC/P2
:EPSON Remote

- ESC/P control codes
 - General Operation:
 - Initialize Printer : ESC @
 - Unidirectional Printing : ESC U
 - CSF Mode Control : ESC EM

 - Paper feeding:
 - Form Feed : FF
 - Line Feed : LF
 - Line Spacing : ESC 0, ESC 2, ESC 3, ESC +
 - Carriage Return : CR

 - Page format:
 - Page Length :ESC (C, ESC C, ESC C0
 - Left / Right Margin :ESC Q, ESC1
 - Top / Bottom Margin :ESC (c, ESC N, ESC O

 - Printer position motion:
 - Horizontal Print Position :ESC \$, ESC\
 - Vertical Print Position :ESC(V, ESC (v
 - Tab Horizontally :ESC D, HT
 - Tab Vertically :ESC B, VT
 - Advance paper :ESC J

 - Font Selection:
 - Typeface :ESC k, ESC x
 - Pitch and Point :ESC X
 - Pitch :ESC P, ESC M, ESC g, ESC p
 - Italic Font :ESC 4, ESC 5
 - Bold Font :ESC E, ESC F
 - Master Select :ESC!

 - Font enhancement:
 - Double-Width :ESC W, DC4, SO
 - Condensed :DC2, SI
 - Double-height :ESC w
 - Double-Strike :ESC G, ESC H
 - Super / Subscript :ESC T, ESC S
 - Underline :ESC-
 - Line / Score :ESC(-
 - Character Style :ESC q

 - Spacing:
 - Intercharacter Space :ESC Space
 - HMI :ESC c
 - Define Unit :ESC (U

 - Character handling:
 - Character Table :ESC t, ESC (t
 - International Character :ESC R
 - User-Defined Characters :ESC %, ESC &, ESC:
 - Upper Control Codes :ESC 6, ESC7
 - Print Data as Characters :ESC(^

- Bit image:
 - Bit Image :ESC*

- Graphics:
 - Graphics Mode :ESC (G
 - Raster Graphics :ESC.
 - Microweave control :ESC (i
 - Dot size control :ESC (e
 - Horizontal Position :ESC (\
 - Printing Speed :ESC(s

- Printing mode:
 - Printing mode :ESC (K

- Color:
 - Printing Color :ESC r, ESC (r

- EEPROM control
 - EEPROM control :ESC |

1.3 Interface

This printer provides both parallel and serial interface as standard.

1.3.1 Parallel Interface (Forward Channel)

[Transmission mode]	:8 bit parallel, IEEE-1284 compatibility mode
[Synchronization]	:By /STROBE pulse
[Handshaking]	:BY BUSY and /ACKNLG signal
[Signal level]	:TTL compatible level
[Adaptable connector]	:57-30360 (amphenol) or equivalent

BUSY signal is set high before setting either/ERROR low or PE high and held high until all these signals return to their inactive state.

BUSY signal is at high level in the following cases.

- During data entry (see Data transmission timing)
- When input data buffer is full
- During -INIT signal is at low level or during hardware initialization
- During printer error (See /ERROR signal)
- When the parallel interface is not selected.

ERROR signal is at low level when the printer is in one of the following states.

- Printer hardware error (fatal error)
- Paper-out error
- Paper-jam error
- Ink-out error

PE signal is at high level during paper-out error.

Table 1-11 shows the signal and connector pin assignments for parallel interface(forward channel*1). In case of these signals, twist pair line is used and returning side is connected to signal GND (*1). Forward channel is the mode when the ordinary data such as print data is sent from the PC to the printer.

Table 1-11. Signal and Connector Pin Assignment for Parallel Interface

Pin No.	Signal Name	Return GND pin	I/O	Functional Description
1	/STROBE	19	In	The strobe pulse. Read-in of data is performed at the falling edge of this pulse.
2-9	DATA0-7	20-27	In	The DATA0 through DATA7 signals represent data bits 0 to 7, respectively. Each signal is at high level when data is logical 1 and low level when data is logical 0.
10	/ACKNLG	28	Out	This signal is a negative pulse indicating that the printer can again accept data.
11	BUSY	29	Out	A high signal indicates that the printer cannot receive data.
12	PE	28	Out	A high signal indicates paper-out error.
13	SLCT	28	Out	Always at high level when the printer is powered on.
14	/AFXT	30	In	Not used.
31	/INIT	30	In	The falling edge of a negative pulse or a low signal on this line causes the printer to initialize. Minimum 50 us pulse is necessary.
32	/ERROR	29	Out	A low signal indicates printer error condition.
36	/SLIN	30	In	Not used.
18	Logic H	-	Out	Pulled up to +5V via 3.9K ohm resistor.
35	+5V	-	Out	Pulled up to +5V via 3.3K ohm resistor.
17	Chassis GND	-	-	Chassis GND.
16,33,19-30	GND	-	-	Signal GND.
15,34	NC	-	-	Not connected.

Note) "I/O" refers to the direction of signal flow from the printer's point of view.

1.3.2 Parallel Interface (Reverse Channel)

[Transmission mode]	:IEEE-1284 nibble mode
[Synchronization]	:Refer to the IEEE-1284 specification
[Handshaking]	:Refer to the IEEE-1284 specification
[Data transmission timing]	:Refer to the IEEE-1284 specification
[Signal level]	:IEEE-1284 level 1 device :TTL compatible level
[Adaptable connector]	:57-30360 (amphenol) or equivalent
[Extensibility request]	:The printer responds affirmatively when the extensibility request values are 00H or 04H, that mean; 00H :Request Nibble Mode Reverse Channel Transfer. 04H :Request device ID; Return Data using Nibble Mode Rev Channel Transfer.

Note) The printer sends following device ID string when it is requested.

Table 1-12. Device ID Description

•q00H•r	•q3CH•r	Contents
MFG	EPSON	Production Maker
CMD	ESCPL2,BDC	Command system
MDL	Stylus[SP]Color[SP] 600	Model name
CLS	PRINTER	Class

- [00H] denotes a hexadecimal value of zero. MDL value depends on the EEPROM setting.
- MDL value depends on the EEPROM setting. Model name can be changed by changing a certain address in the EEPROM.

The table below shows pin assignment for reverse channel(*3). In these case of signals, twist pair line is used and returning side is connected to Signal GND. (*3):Reverse channel is the mode that any data is transferred from the printer to the PC.

Table 1-13. Pin Assignment for Reverse Channel

Pin No.	Signal Name	Return GND pin	I/O	Functional description
1	HostClk	19	In	Host clock signal.
2-9	Data0-7	20-27	In	The DATA0 through DATA7 signals represent data bits 0 to7, respectively. Each signal is at high level when data is logical 1 and low level when data is logical 0. These signals are used to transfer the 1284 extensibility request values to the printer.
10	PrtClk	28	Out	Printer clock signal.
11	PtrBusy, Data Bit-3,7	29	Out	Printer busy signal and reverse channel transfer data bit 3 or 7.
12	AckDataReq, DataBit-2,6	28	Out	Acknowledge data request signal and reverse channel transfer data bit 2 or 6.
13	Xflag, DataBit-1,5	28	Out	X-flag signal and reverse channel transfer data bit 1 or 5.
14	HostBusy	30	In	Host busy signal.
31	/INIT	30	In	Not used.
32	/DataAvail, DataBit-0,4	29	Out	Data available signal and reverse channel transfer data bit 0 or 4.
36	1284-Active	30	In	1284 active signal.
18	Logic-H	-	Out	Pulled up to +5V via 3.9K ohm resister.
35	+5V	-	Out	Pulled up to +5V via 3.3K ohm resister.
17	Chassis GND	-	-	Chassis GND.
16,33 19-30	GND	-	-	Signal GND.
15, 34	NC	-	-	Not connected.

Note) "I/O" refers to the direction of signal flow from the printer's point of view.

Following lists “Notes” when using Parallel Interface.

- ❑ “Return GND pin” in the table means twist pair return and is used for all control signals except for Logic H,+5V, Chassis, GND and NC. In this twist pair return, returning side is connected to GND (16,33, 19-30 pin) for twist pair return. Also, these cables are shielded wires and it is effective to connect to each chassis GND in the PC and printer for electrostatic noise.
- ❑ Conditions for Interface are based on TTL level. Rise and fall time should be within 0.2ms.
- ❑ Refer to the figure 1-9 for transmission timing of each signals.
- ❑ Do not perform data transmission ignoring /ACK or BUSY signal. (Perform the data transmission after confirming that /ACK and BUSY signals are Low.)
- ❑ It is possible to perform the printing test including interface circuit without using equipment from outside when 8-bit data signal(20-27 pin) is set to appropriate word code and connect them forcefully to /ACK and /STRB.

[Data Transmission Timing for Forward Channel]

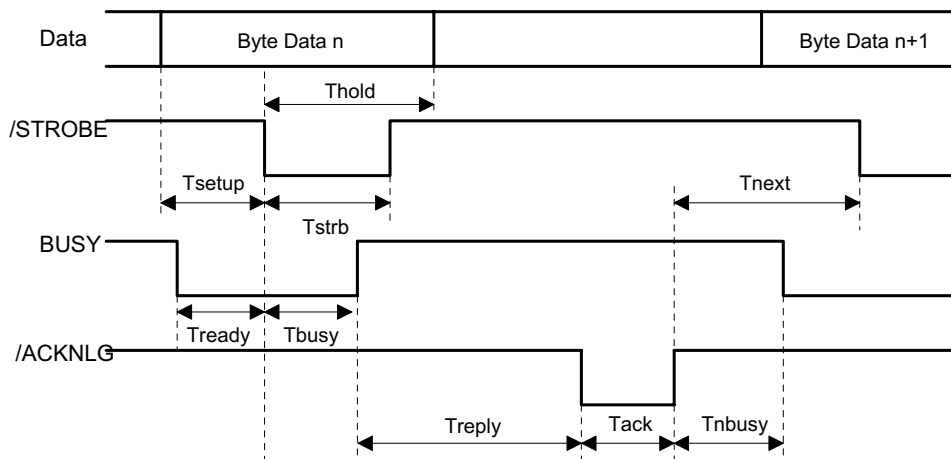

Figure 1-9. Parallel Interface Timing Chart(Forward Channel)

Table 1-14. Timing Parameters and Value

Parameter	Minimum	Maximum
tsetup	500ns	---
thold	500ns	---
tstb	500ns	---
tready	0	---
tbusy	---	500ns
tt-out*	---	120ns
tt-in**	---	200ns
treply	0	---
tack	500ns	10us
tnbusy	0	---
tnext	0	---

Note) *: Rise and fall time of every output signals.
 **: Rise and fall time of every input signals.

Table 1-15. Typical Time of Tack

Parallel I/F mode	Typical time of tack
High speed	2us
Normal speed	4us

[Signal level: TTL compatible (IEEE-1284 level 1 device)]

Table 1-16. Signal Level

Parameter	Minimum	Maximum	Condition
VOH*	---	5.5V	
VOL*	-0.5V	---	
IOH*	---	0.32mA	VOH = 2.4V
IOL*	---	12mA	VOL = 0.4V
CO	---	50pF	
VIH	---	2.0V	
VIL	0.8V	---	
IIH	---	0.32mA	VIH = 2.0V
IIL	---	12mA	VIL = 0.8V
CI	---	50pF	

Note) *: A low logic level on the Logic H signal is 2.0V or less when the printer is powered off and this signal is equal or exceeding 3.0V when the printer is powered on. The receiver shall provide an impedance equivalent to 7.5K ohm to ground.

[Data Transmission Timing for Reverse Channel]

The figure below shows timing chart of Parallel Interface Reverse channel.

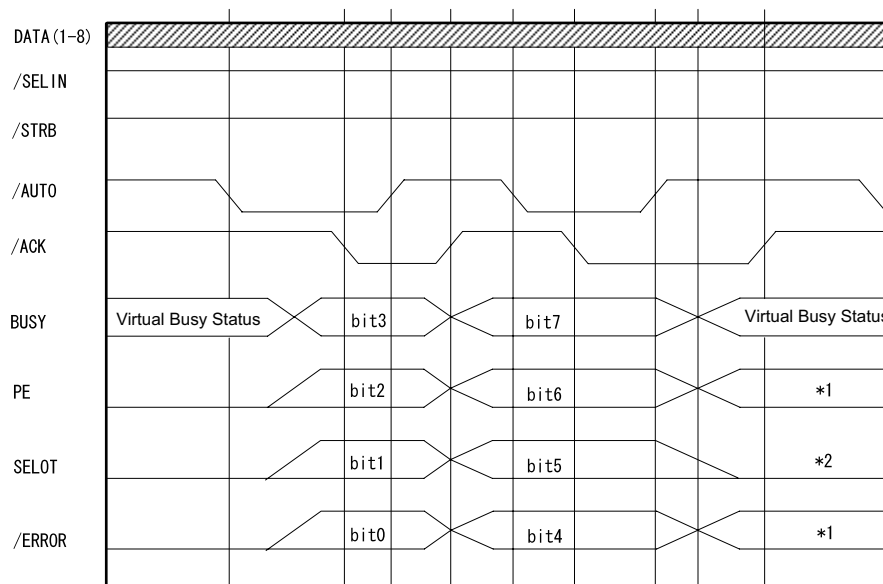

Figure 1-10. Parallel Interface Timing Chart(Reverse Channel)

1.3.2.1 Prevention Hosts from Data Transfer time-out

Generally, hosts abandon data transfer to peripherals when a peripheral is in the busy state for dozens of seconds continuously. To prevent hosts this kind of time-out, the printer receives data very slowly, several bytes per minute, even if the printer is in busy state. This slowdown is started when the rest of the input buffer becomes several hundreds of bytes. Finally, the printer is in the busy state continuously when the input buffer is full.

1.3.3 Serial Interface

[Standard]	:Based on RS-423
[Synchronization]	:Synchronous
[Bit Rate]	:Approx. 900Kbps
[Handshaking]	:X-ON/X-OFF, DTR Protocol
[Word Format]	:Data Bit = 8 bits
	:Parity Bit = None
	:Start Bit = 1 bit
	:Stop Bit = 1 bit
[Connector]	:8-pin mini-circular connector
[Recommended Cable]	:Apple System Peripheral-8 Cable (Part #: M0197)

Table 1-17. Pin Assignment

Pin No.	Signal Name	I/O	Description
1	SCLK	O	Synchronous clock signal
2	CTS	I	Clear To Send
3	TXD-	O	Transmit Data (-)
4	SG	I	(Signal Ground)
5	RXD-	I	Receive Data (-)
6	TXD+	O	Balanced Transmit Data (+)
7	DTR	O	Data Terminal Ready
8	RXD+	I	Balanced Receive Data (+)

Table 1-18. X-ON/X-OFF and DTR Status

State	Buffer Space	X-ON/X-OFF	DTR
Busy	Less than 3072 bytes	Send X-OFF code	OFF
Ready	More than 5120 bytes	Send X-ON code	ON

1.4 Control Panel

Since EPSON Stylus Color 600 does not require many buttons since printer driver can start various settings and motions. Therefore, there are only 2 non-lock type push switches, 1 lock type push switch and 4 LEDs.

Following figure shows control panel of EPSON Stylus Color 600.

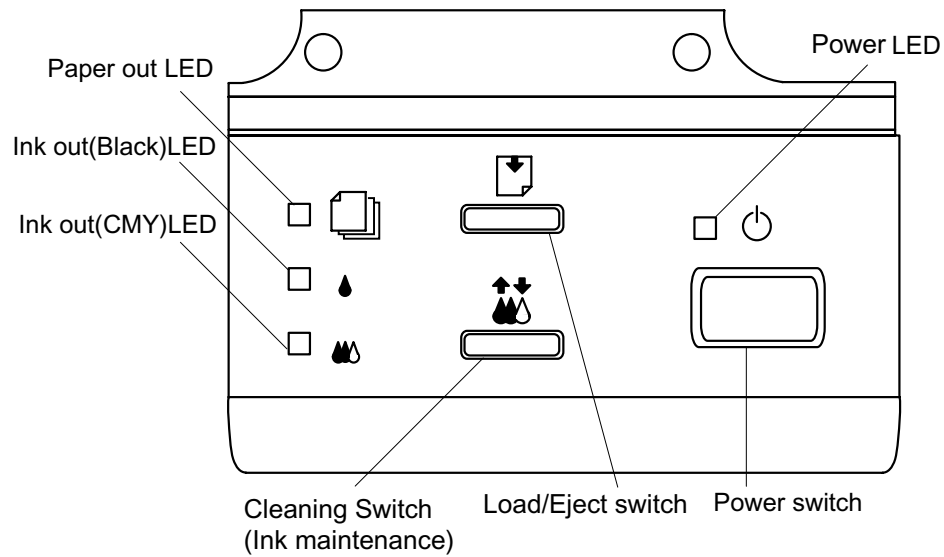

Figure 1-11. Control Panel

1.4.1 Indicators

- ❑ **Power**
Lights when the operate switch is "ON", and AC power is supplied.
- ❑ **Paper out**
Lights during the paper-out condition, and blinks during the paper-jam condition.
- ❑ **Ink Out (Black)**
Lights during no Black ink condition, and blinks during the Black ink low condition.
- ❑ **Ink Out (Color)**
Lights during no Color ink condition, and blinks during the Color ink low condition.

1.4.2 Panel Functions

•q Panel Functions •r

Table 1-19. Panel Function

Switch	Function
Load/Eject (Pushing within 0.5 seconds*)	<input type="checkbox"/> Loads or Eject the paper. <input type="checkbox"/> When the carriage is on the Ink Cartridge change position, return the carriage from Ink Cartridge change position.
Load/Eject (Pushing for 2 seconds*)	<input type="checkbox"/> Starts the Ink Cartridge change sequence.** Moves the carriage to cartridge change position.
Cleaning (Pushing for 2 seconds*)	<input type="checkbox"/> Starts the Head Cleaning sequence.*** <input type="checkbox"/> In the condition of "Ink Low" or "Ink Out" or "No Ink Cartridge" starts the Ink Cartridge change sequence.**
Cleaning (Pushing within 2 seconds*)	<input type="checkbox"/> When carriage is on the Ink Cartridge change position, return carriage from Ink Cartridge change position.

Note) *: 3 seconds is required at the User's manual.

** : This function is not available in printing status.

*** : The time to complete the sequence may vary depending on the printer's status.

•q Panel Functions with Power ON •r

Table 1-20. Panel Function with Power ON

Switch	Function
Load/Eject	<input type="checkbox"/> Starts status printings.**
Cleaning	<input type="checkbox"/> Enter the Default Setting mode
Load/Eject + Cleaning	<input type="checkbox"/> Enters the particular settings mode. (Factory use only.) To enter the particular settings mode, it is necessary to push followings switch while Paper Out LED is blinking.(It blinks about 5 seconds)

Note) **: status printings prints firmware version, ink counter, selected code page and nozzle check patterns.

•q Particular setting mode •r

Table 1-21. Particular Setting Mode

Switch	Function
Load/Eject	<input type="checkbox"/> Initialize EEPROM *** and reset Timer IC.

Note) ***: Refer to EEPROM map.

By performing a particular setting mode, Maintenance error can be cleared and certain addresses of EEPROM can also be reset.

❑ Maintenance Error Clear

- [Step 1] Turn the printer on while holding down Load/Eject and Cleaning switches at the same time.
(By operating this performance, the Paper Out LED starts blinking.)
- [Step 2] Push the Load/Eject switch while the Paper Out LED is blinking (5 seconds).

Following shows the lists that will be cleared by this performance.

- ❑ Clear the value of Ink Counter
- ❑ Clear Time IC
- ❑ Initialization of I/F selection (returns to AUTO)



- ☑ *EPSON Stylus Color 600 does not have "EEPROM All Clear" function like other printers. If the printer does not function well and falls into fatal error condition, replace the main board to see if the problem is rectified. (Refer to Chapter 4 "Adjustment" when you replace the main board since some adjustments will be necessary.)*
- ☑ *Be sure to replace a waste ink pad in the printer enclosure with a new one after you perform Maintenance error clear operation.*

1.4.3 Printer Condition and Panel Status

The table below shows printer condition and panel status. Since this table shows various error status and also present printer status, you can judge appropriate repair ways from this table.

Table 1-22. Printer Condition and Panel Status

Printer status	Indicators				Priority
	Power	Ink Out (Black)	Ink Out (Color)	Paper Out	
Power on condition	On	---	---	---	9
Ink sequence	Blink	---	---	---	6
Ink Cartridge change mode	Blink	---	---	---	5
Data processing	Blink	---	---	---	8
Paper Out	---	---	---	On	4
Paper jam condition	---	Off	Off	Blink	3
No Ink cartridge or Ink end(black)	---	On	---	---	7
Ink level low(black)	---	Blink	---	---	7
No Ink cartridge or Ink end(color)	---	---	On	---	7
Ink level low(color)	---	---	Blink	---	7
Enter EEPROM and Timer IC reset	---	On (1 second only)	On (1 second only)	On (1 second only)	--
Maintenance request	Blink	Blink	Blink	Blink	2
Fatal error	Blink	On	On	Blink	1

Note) "—" means no changes.

1.5 Error Status

When following status occur, the printer goes to the error status and stops taking data, setting the /ERROR signal in the interface as “Low”, and Busy signal as “High”. At this time, the printer goes to non printable status. Refer to section 1.4.2 for more details of LED Panel indicators during the various error status.

1.5.1 Ink Out

When the printer runs out the most part of the ink of any one color, it warns ink-low and keeps printing. When the printer runs out the whole ink of any one color, it stops printing and indicates ink-out error. User is requested to install a new ink-cartridge in this state. An ink-cartridge once taken out should never be used again. Re-installation of the cartridge not filled fully upsets the ink level detection and may cause a serious problem in the print head as a result.



Never use the ink cartridge once taken out from the printer.

Following explains the reason of the above warning.

- After the cartridge is once taken out, airs come in from the ink supply hole located at the top of cartridge and becomes bubbles, and they are absorbed into the head during printing performance. Therefore, the head will be unable to discharge the ink properly. Also, inevitable entering of bubbles when installing a new ink cartridge can be absorbed to ink itself since the ink itself in the cartridge is deaerated during the production process. However, this absorbing ability can last only about one hour after the cartridge is installed.
- Even after the bubble absorbing ability described above stops, there is no worry about entering bubbles as long as the ink cartridge is being installed to the printer. However, if the ink cartridge which does not have absorbing ability any more is once removed from the printer, new coming bubbles into the cartridge will never disappear naturally. These bubbles may cause not only printing malfunction but also thickening ink. This thickened ink goes into the head and clogs ink path in the head or nozzle and may cause serious head damage.
- As standard specification for EPSON Stylus Color 600, ink consumption counter is reset when the ink cartridge is removed. If an ink cartridge is removed and re-installed unnecessarily the value on the ink consumption monitor which the user can check will be wrong and printer may keep printing even though the ink cartridge is installed empty. This may cause head damage.

1.5.2 Paper Out

When printer fails to load a sheet after power on operation including timer-cleaning is done and Load/Eject button on the FF command or operation panel is pressed, it goes paper out error.

1.5.3 Paper Jam

When printer fails to eject a sheet even after feeding motion is completed or Load/Eject button on the FF command or operation panel is pressed, it goes paper jam error.

1.5.4 No Ink-Cartridge Error

Following reasons can be the causes when printer goes this error mode.

- ❑ When the printer is turned on for the first time.
(This is a normal error state and it returns to the normal state after installing an ink cartridge according to the ink cartridge exchange operation.)
- ❑ Ink cartridge exchange operation is done correctly. After the position of carriage is moved by exchange operation, if the cleaning switch is pushed without installing ink cartridge or if the carriage returns to the home-position automatically without doing any operation, it is considered as handling mistake. However, it returns to normal state by performing ink exchange operation again and installing cartridge correctly.
- ❑ If “No ink-cartridge error” appears even after the ink cartridge is installed, the printer must be something wrong and around the sensor area in the carriage need to be repaired.
- ❑ If sometimes printer can print normally but also sometimes “No ink-cartridge error” appears, the printer must be something wrong. (Same reason as above)

1.5.5 Maintenance Request

When the total quantity of ink wasted through the cleanings and flushing reaches to the limit, printer indicates this error and stops. The absorber in the printer enclosure is needed to be replaced with new one by a service person. The ink quantity that is absorbed by the absorber (waste ink pad) is monitored by the software counter as “total ink counter”. This counter is added by point system and absorber’s maximum ability is set at the following reference value.

$$29500 \times 0.012 \text{ ml} = \text{Approximately } 301 \text{ ml}$$

- 1-point = 0.0102 ml (the value which is multiplied evaporating rate and 1-dot ink weight 0.02 ml)
- 29500 = Maximum point number (Maintenance error threshold)

However, considering dispersion of ink absorbing quantity and the number of using nozzles, ink total value is calculated by the following formula.

$$301 \times 1.1/63\% = 526 \text{ ml (but up to } 532 \text{ ml can be retained)}$$



When you perform self- test after completing repairs, it is possible to check the present value of total ink counter and ink discharge conditions from all nozzles by performing status printing in the built-in function. Therefore, make sure that the printer has enough value of total ink counter (if the number is close to 29500 or not). If there is not enough value, the service man is required to judge if it is necessary to clear EEPROM after replacing the absorber (waste ink pad) or not. Refer to section 1.3.1 if you need to perform EEPROM Clear.

1.5.6 Fatal Errors

When printer detects fatal errors such as carriage control error or CG access error, it goes to this error mode. Refer to followings for each error.

- ❑ Carriage control Error: Parallel adjustment malfunction, Home-position malfunction, Timing belt tension malfunction, shortage of lubricant on the carriage guide shaft, etc.
- ❑ CG Access Error: Short circuit, etc.

1.6 Printer Initialization

EPSON Stylus Color 600 has three kinds of initialization methods. Following explains each initialization.

- Power-on initialization
This printer is initialized when turning the printer power on, or printer recognized the cold-reset command (remote RS command). When printer is initialized, following action is performed.
 - Initializes printer mechanism.
 - Clears input data buffer.
 - Clears print buffer.
 - Sets default values.

- Operator initialization
This printer is initialized when turning the printer power on again within 10 seconds from last power off, or printer recognize the /INIT signal (negative pulse) of parallel interface. When the printer is initialized, following action is performed.
 - Cap the printer head.
 - Eject a paper.
 - Clears input data buffer.
 - Clears print buffer.
 - Sets default values.

- Software initialization
The ESC@ command also initialize the printer. When printer is initialized, following action is performed.
 - Clears print buffer.
 - Sets default values.

1.6.1 Initialization Settings

EPSON Stylus Color 600 initializes following settings when the initialization is performed. Also, if the user changes the settings in the Panel setting, Default setting or Remote command setting, values or settings which are possible to be stored are initialized as initialization settings.

- | | |
|-------------------------|--|
| ■ Page position | :Page heading location as present paper location |
| ■ Line spacing | :1/6 inch |
| ■ Right margin position | :80 lines |
| ■ Left margin position | :first line |
| ■ Character pitch | :10CPI |
| ■ Printing mode | :Text mode (Not Raster graphics mode) |

1.7 Main Components

EPSON Stylus Color 600 has following major units. Also, it is one of the major characteristics that the bottom of the Printer mechanism plays the role as lower case at the same time.

- ❑ Upper case
- ❑ Printer Mechanism
- ❑ C200 MAIN Board (Main control circuit board)
- ❑ C206 PSB/PSE Board (Power supply circuit board)
- ❑ C206 PNL Board (Control panel circuit board)

1.7.1 Printer Mechanism

Unlike EPSON's previous ink jet printer mechanisms, one of the major characteristics of EPSON Stylus Color 600 is that the printer has no Engage/Disengage mechanism in order to change over pump mechanism and paper feeding mechanism. Instead, however, this change-over control is done by the distinction between turning direction of PF motor and position of present carriage unit. Also, another major characteristic is that print head is changed to be one unit combined with black and CMY. Nozzle configuration for black is 64 nozzles (the nozzle pitch of each column is 90dpi and between two consecutive nozzles in number (e.g. #1 and #2) is 180dpi). On the other hand, CMY nozzle has 32 nozzles (90dpi) for each color. Following figure shows exterior of mechanism.

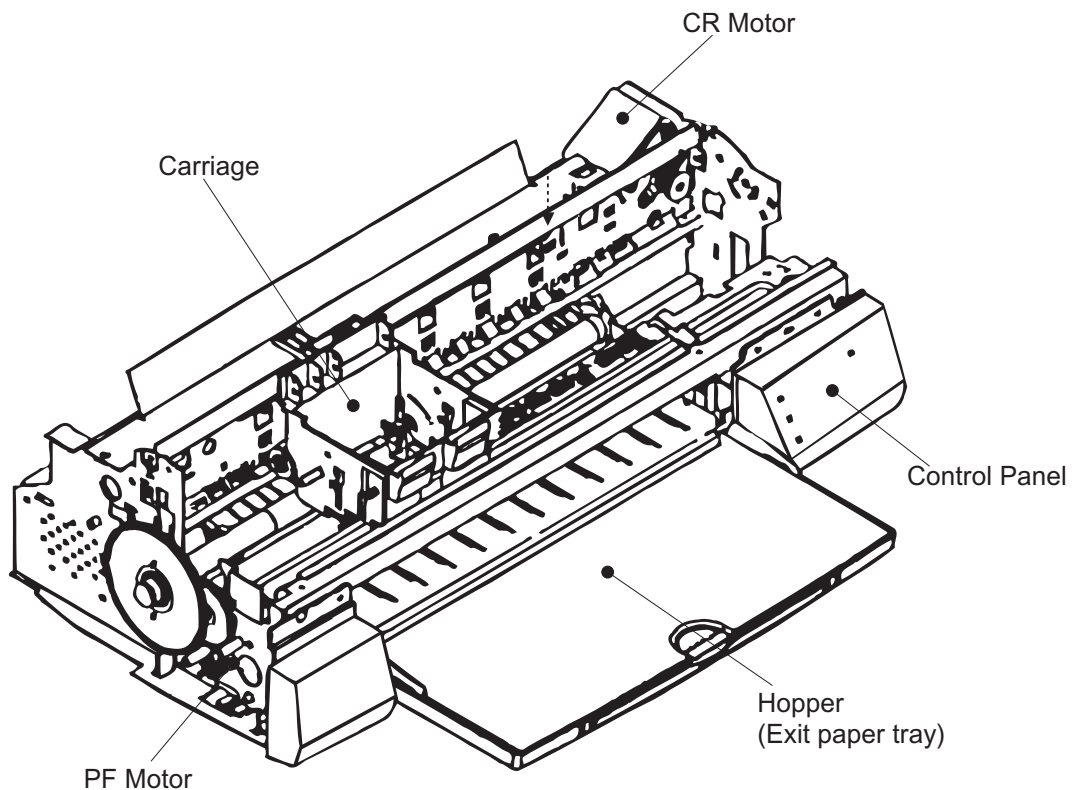

**ASF is not shown in the above figure.*

Figure 1-12. Exterior view of the Printer Mechanism

1.7.2 C200 MAIN Board

The C200 MAIN board controls whole mechanism operations and a data processing operation. Most of the functions of the circuit are integrated into single ASIC; E05B43YA (IC2) and this makes the board design very simple and reliable.

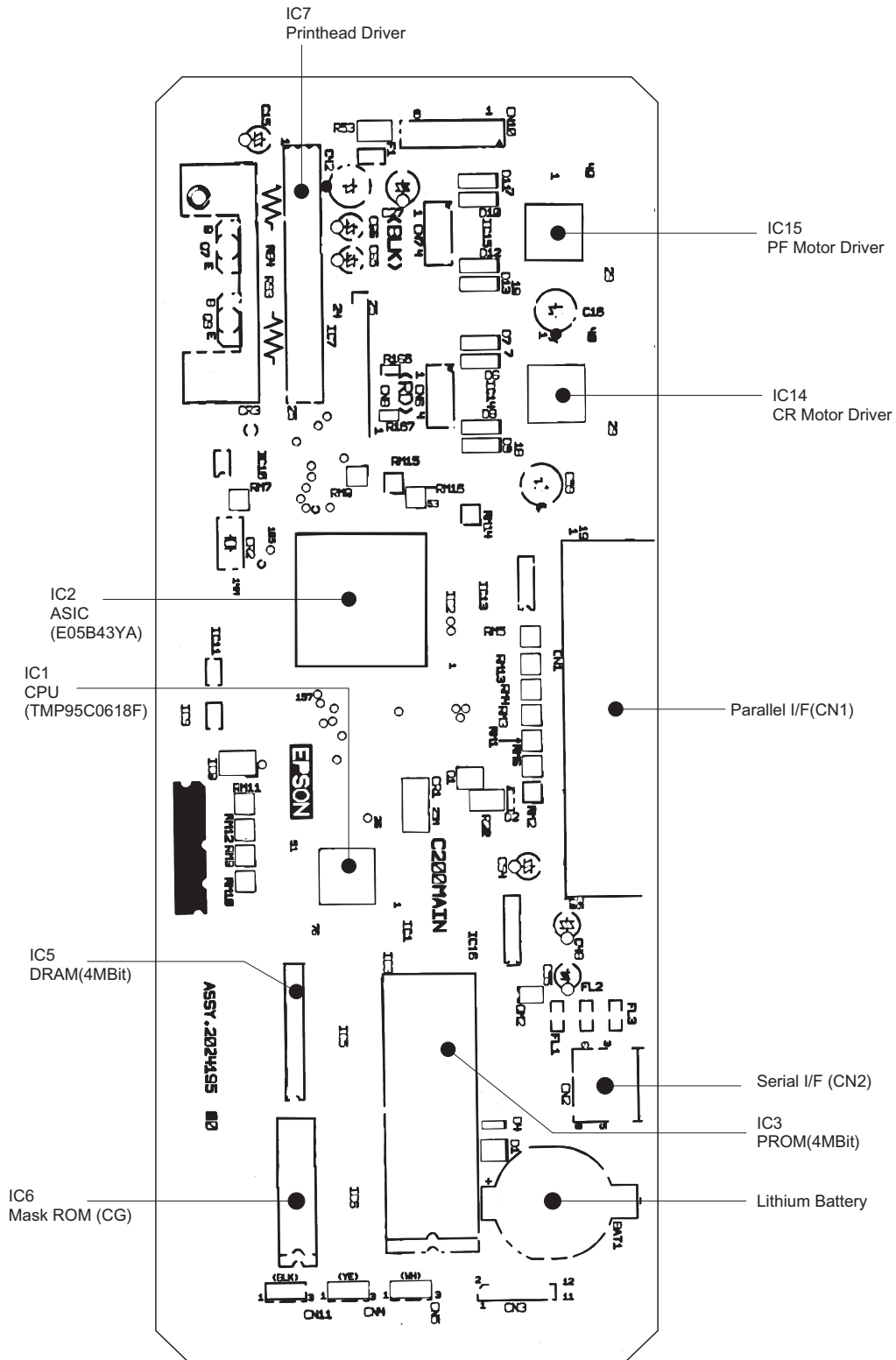

Figure 1-13. Exterior view of C200 Main Board

1.7.3 C206 PSB/PSE Board

The C206 PSB/PSE board is a switching regulator type power supply unit and constantly supplies stable logic and power voltages to the printer mechanism and the main control board. Also, since this C206 PSB/PSE board has the power switch in the secondly side of the circuit, it is possible to keep supplying electricity to the C200 MAIN control board for 30 seconds even after the power switch is turned off. Using this time difference, even when mis-operation is done by the user such as turning off the power during the middle of printing work, it prevents unexpected trouble with the printhead from occurring, by transferring the printhead to the cap position before complete shut down. The C206 PSB Board is for AC100 - 120V input voltage and the C206 PSE Board is for AC220 - 240V input voltage.

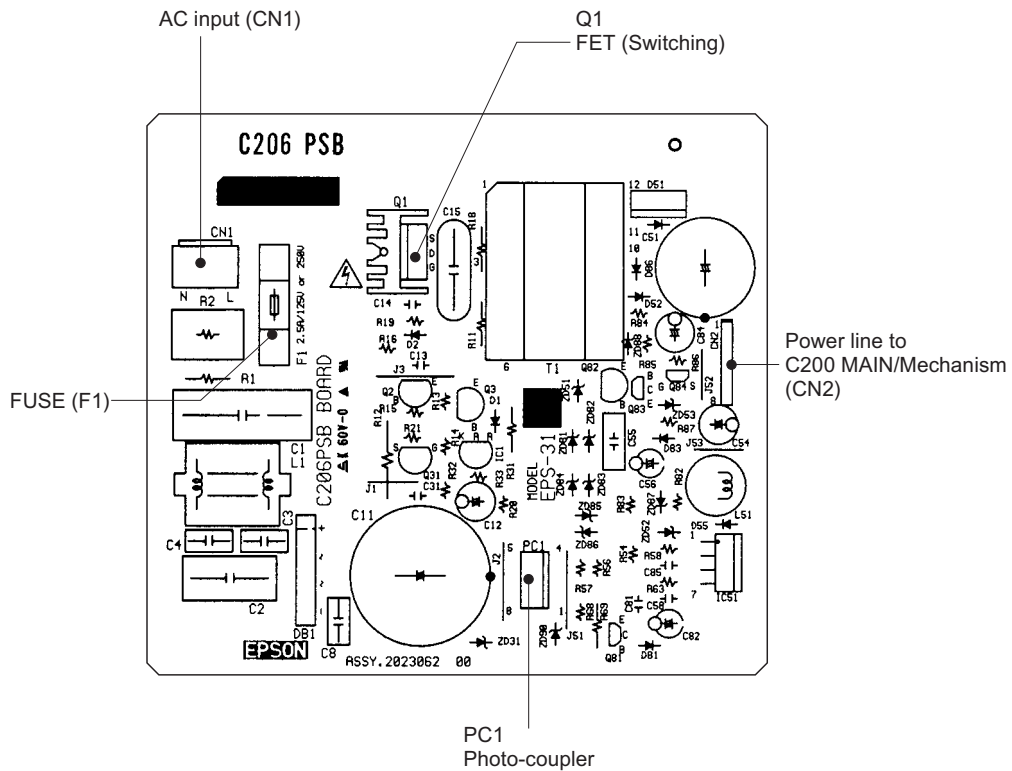

Figure 1-14. Exterior view of C206 PSB Power Supply Board

1.7.4 C206 PNL Board

The C206 PNL board is located in the panel case where is in the right bottom of the front of printer and consists of 3 switches, 4 LEDs.

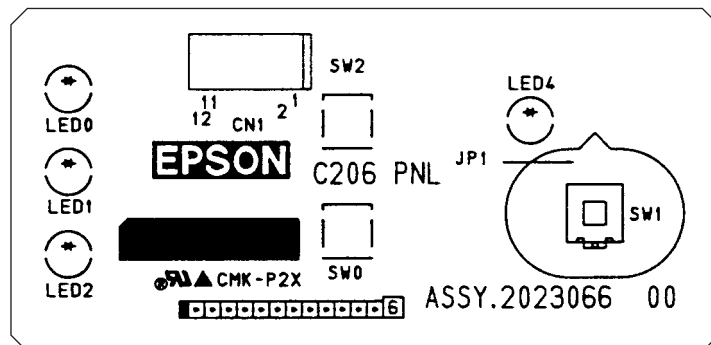

Figure 1-15. Exterior view of C206 PNL Board

Chapter 2

Operating Principles

2.1 OVERVIEW	2-1
2.1.1 Printer Mechanism	2-1
2.1.1.1 Printing Mechanism	2-2
2.1.1.1.1 Printing Process.....	2-3
2.1.1.1.2 Printing Method	2-4
2.1.1.2 Carriage Mechanism.....	2-7
2.1.1.2.1 Platen Gap Adjust Mechanism and Parallel adjustment Mechanism.....	2-10
2.1.1.3 Paper Feed Mechanism and Pump Mechanism	2-11
2.1.1.4 Ink System	2-14
2.1.1.4.1 Pump, Carriage Lock, Head Cleaner Mechanism	2-15
2.1.1.4.2 Cap Mechanism	2-17
2.2 Electrical Circuit Operating Principles	2-18
2.2.1 C206 PSB/PSE Power Board	2-19
2.2.2 C200 Main Board	2-21
2.2.2.1 Reset Circuits	2-23
2.2.2.2 Sensor Circuits	2-24
2.2.2.3 EEPROM Control Circuits.....	2-25
2.2.2.4 Timer Circuit	2-26
2.2.2.5 DRAM Control	2-26
2.2.2.6 Print Head Control Circuit	2-27
2.2.2.7 PF(Pump) Motor Drive Circuit	2-30
2.2.2.8 CR Motor Drive Circuit	2-31

2.1 OVERVIEW

This section describes Printer Mechanism, electric circuit board (C206 PSB, C200 Main, C206PNL board) of Stylus Color 600.

2.1.1 Printer Mechanism

Unlike previous EPSON Ink Jet printers, printer mechanism of Stylus Color 600 does not have exclusive mechanism to change over paper feeding and Pumping operation. In stead, this control is done by the turning direction of paper feed/pump motor and position of carriage at that time. Also, unlike previous print heads, print head of this printer is became one unit combined with black and CMY head. Black head has 64 nozzles, 180 dpi(vertical direction) and CMY head has 32 nozzles, 90 dpi (vertical direction). Also, since these print head is driven by frequency 14.4KHz, this printer can print double resolution(1440 dpi/100-dpi) than Stylus Color. Following figure2-1 shows outline of printer mechanism.

Since the head drive frequency of Stylus Color was 7.2KHz, it could be only 720-dpi printing when it driven by 100 cps carriage speed. It performs two-pass carriage operation when Stylus Color 600 performs the 1440 dpi printing towards the horizontal line.

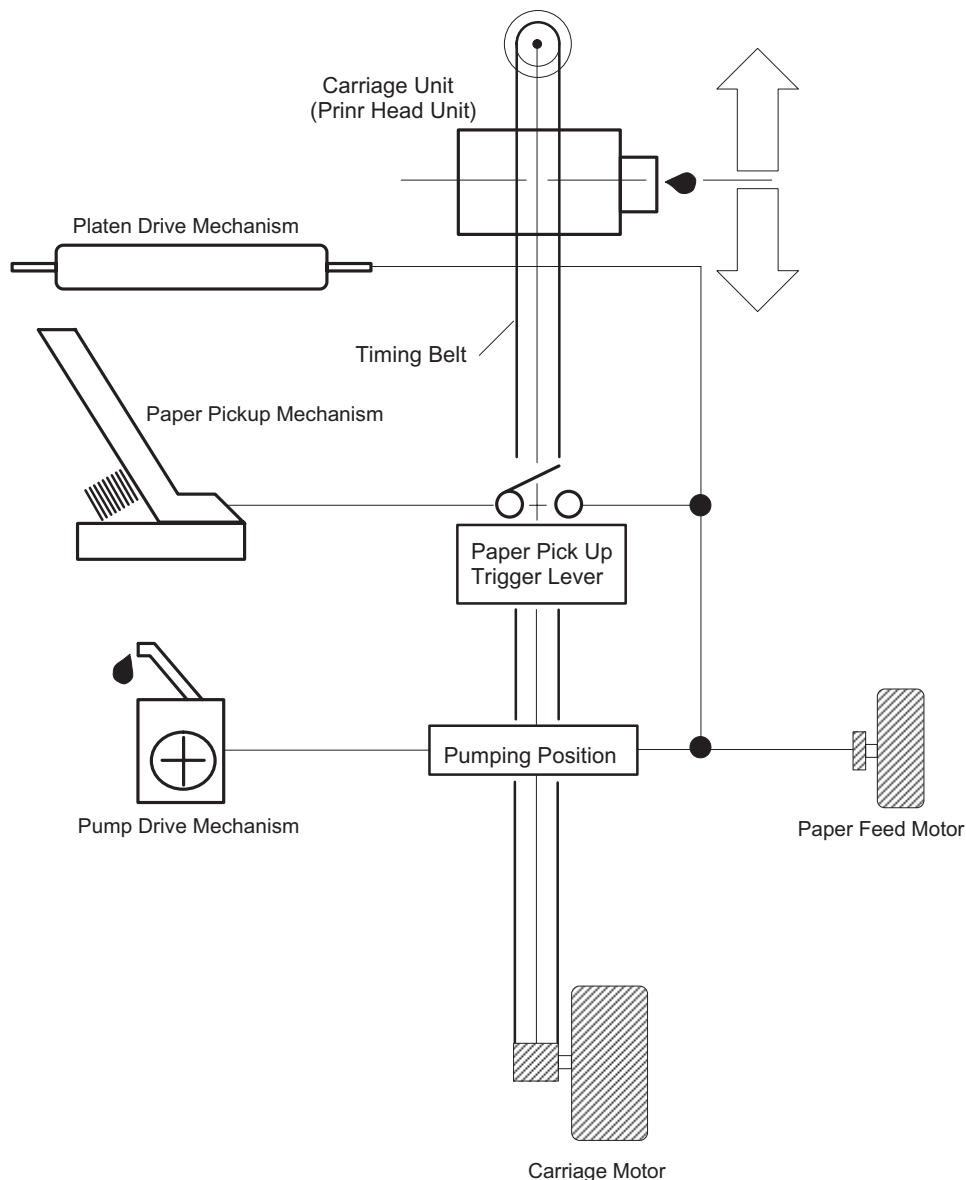

Figure 2-1. Stylus Color 600 Printer Mechanism Block Diagram

As major printer mechanisms in the figure 2-1, there are four major mechanisms as they are listed below.

- 1) Printing mechanism
- 2) Carriage unit
- 3) Paper pick up mechanism
- 4) Pump drive mechanism

2.1.1.1 Printing Mechanism

Basic principles of the print head which plays major role of printing mechanism is the same as previous models; on demand type MACH head method, but there is some difference in the resolution. (Refer to figure1-1) Also, unlike Stylus Color II, Stylus 820 and Stylus Color 200 automatic correction type, in order to fix the dispersion of multi layer piezo electric element which is used for driving each nozzles, it is necessary to input the VH value written on the side of print head by using exclusive program when you replace print head, control board, or the printer mechanism. (However, there are no resistor array for decide the VH voltage on the main control board.) Following explains print head.

- PZT
 - PZT is an abbreviation of Piezo Electric Element. Print signal from C200 board is sent through the driver board on the print head unit and to the PZT. Then, the PZT pushes the top cavity which has ink stored, and make the ink discharge from each nozzle located on the nozzle plate.
- Cavity Set
 - Ink which is absorbed from ink cartridge go through the filter and will be stored temporarily in this tank, which is called "cavity" until PZT is driven.
- Nozzle Plate
 - The board with nozzle holes on the printer head surface is called Nozzle Plate.
- Filter
 - When the ink cartridge is installed, if any dirt or dust around the cartridge needles are absorbed into the head inside, there is a great possibility of causing nozzle clog and disturbance of ink flow and finally causing alignment failure and dot-missing. In order to prevent this, filter is set at cartridge needle below and ink is once filtered here.

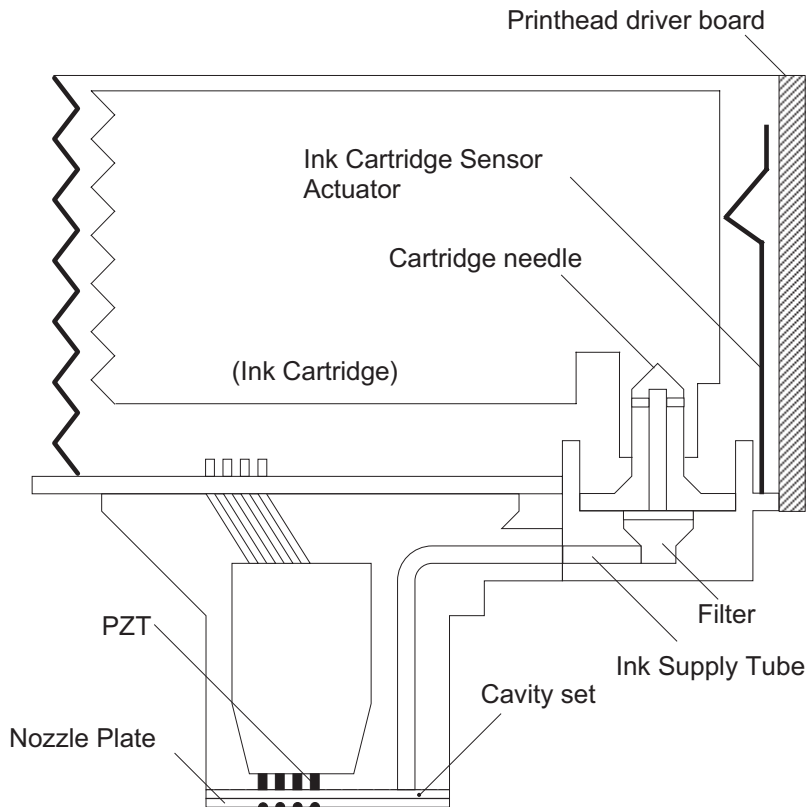

Figure 2-2. Print Head Sectional Drawing

2.1.1.1.1 Printing Process

Following figures indicate the sectional drawing of normal state and ejecting state of print head.

(1) Normal State:

When the print signal is not output, PTZ also does not move in the waiting state(normal state).

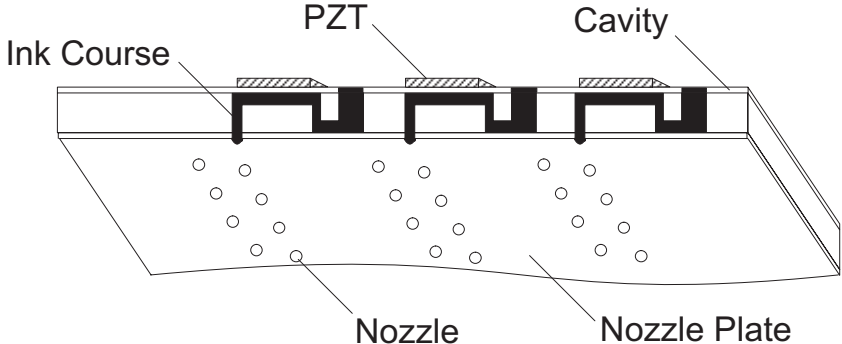

Figure 2-3. Print Head Normal State

(2) Ejecting State:

When the print signal is output from the C200 main board, IC(IR2C72C and IR2C73C:Nozzle Selector) located on the print head unit latches the data once by 1-byte unit. Appropriate PTZ latched by nozzle selector is pushed in to the cavity by applying common voltage from the C200 main board. By this operation, ink that is stored in the cavity pops out from nozzles.

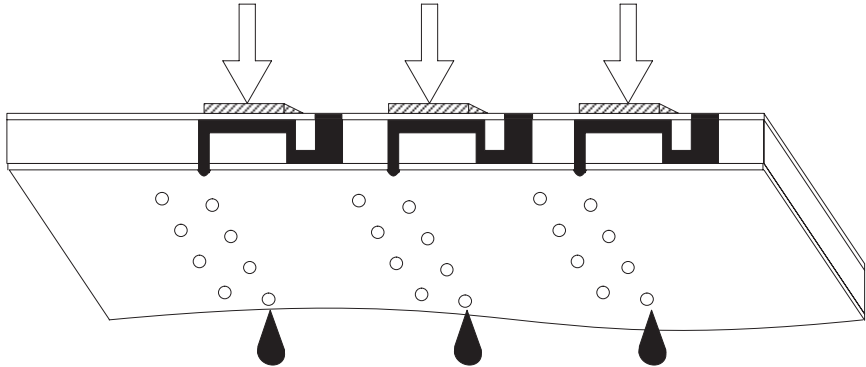

Figure 2-4. Print Head Ejecting State

2.1.1.1.2 Printing Method

This section explains printing method of actual printing such as printing text at various resolution select/printing mode and graphics printing. In order to prevent white or color banding which are peculiar problem of ink-jet, new Micro-Weave functions are added to the previous Micro-Weave function. The number of nozzles and printing mode according to the selected resolution are used separately by a user. The table below shows relation between selected resolution and printing mode.

- 1) Full Overlap Micro-Weave
- 2) Part Line Overlap Micro-Weave
- 3) Micro-Weave: (same as previous control)

Table 2-1. Resolution and Printing mode

Vertical direction [dpi]	Printing mode	Paper feed pitch [inch]	Forward Overlap-Nozzle	Non Overlap-Nozzle	Backward Overlap-Nozzle	Not used Nozzle
360	FOL M/W	15/360	#16•`#30	---	#1•`#15	#31•`#32
	M/W	31/360	---	#1•`#31	---	#32
720	FOL M/W	15/720	#16•`#30	---	#1•`#15	#31•`#32
	POL M/W	29/720	#30•`#32	#4•`#29	#1•`#3	---

- Note1: M/W means Micro-Weave.
- Note2: FOL means Full Overlap Micro-Weave.
- Note3: POL means Part line Overlap Micro- Weave.
- Note4: Forward Overlap-Nozzle and backward Overlap -Nozzle are described in the [1.Full Overlap Mirco-Weave] and [2.Part line Overlap Micro-Weave] below.

Following explains operation outlines of new Micro-Weave functions listed above.

[1. Full Overlap Micro-Weave]

In order to print one line at horizontal direction, this printing method is designed to complete a printing pattern by two-pass carriage operation with two different types of dot. When this two different types of dot pass one same line twice, it does not print the same dot twice.

- The nozzles whose configuration completely match to the black and CMY nozzle are used. (Usually Micro-Weave type)
- Therefore, all nozzles in case of CMY nozzle and #1•`#63 nozzles in the B2 line in case of black head are its objects. (B1 line is not used at Micro-Weave. Refer to figure1-1 for detail of nozzle configuration.)
- Out of these 4 color nozzle objects, the number of all nozzles which are going to be used are divided equally into 2 groups.
- Paper feeding will be done as many as each number of nozzles which are divided into two groups and the same number of dots.(for example, if there are two 10-nozzle groups during 360-dpi printing at longitudinal direction, paper feeding of 10/360-inch becomes available.) At this time, two groups perform Micro-Weave individually and particular lines are passed by two different nozzles.

Note1) These nozzles which are divided into two groups must be set and divided in order to be a pair of odd and even number.

Note2) Two groups which are divided according to each elements will be divided either even dot or odd dot when particular lines(level direction line) are formed and eventually, these lines will be completed at selected resolution. Following is a conceptual figure when full overlap micro-weave orms a particular line.

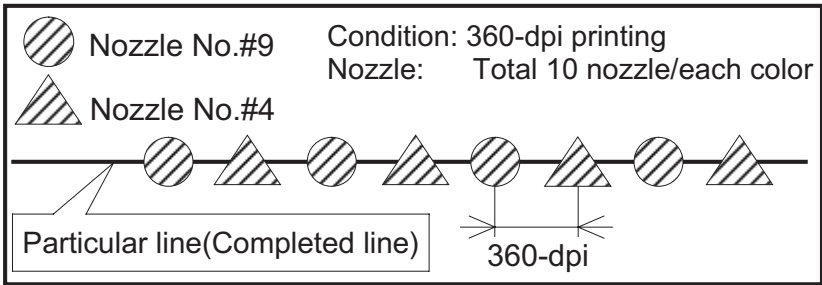

Figure 2-5. Full Overlap Micro-Weave

Note 3) The way firmware decides which nozzle becomes even dot or odd dot is determined as it is described below.

- If the line which is about to be printed is even line:
 - First dot prints odd dot lines and 2nd dot prints even dot lines.
- If the line which is about to be printed is odd line:
 - 1st dot prints even dot lines and 2nd dot prints odd dot lines. Eventually, horizontal resolution will be the same resolution as selected one.

[2.Part Line Overlap Micro-Weave]

This printing method is to perform Micro-Weave printing, overlapping a part of nozzles which are used for printing. As a result, a part of raster which is overlapped consists of different browse with different nozzles. The figure below shows 1-line Overlap at 5-dot sending as an example with explanation on the next page.

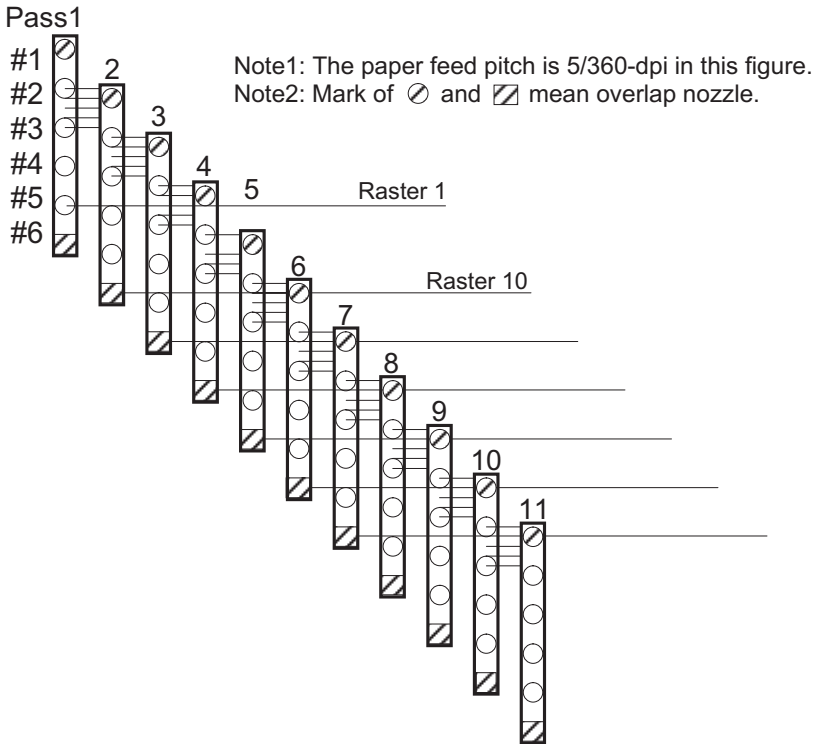

Figure 2-6. Part line Overlap Micro-Weave

- The difference between Full-Overlap Micro-Weave and Part line Overlap Micro-Weave are following;
 - **Full-Overlap Micro-Weave:**
Printing is performed, judging if nozzles are even or odd dot by 2 different dots with all different rasters.
 - **Part line Overlap Micro-Weave:**
After particular nozzles(only#1, and #6 in the figure2-7) are determined as overlap nozzles, even or odd dot will be determined like Full-overlap Micro-Weave does.
(Forward Overlap Nozzle is determined as even and backward nozzle is odd.)
Also, nozzles other than particular nozzles can print at even and odd dot just by one nozzle.

1) Overlap Nozzle : Head drive frequency is driven half of the ordinal one like 2) below.

2) Nozzle other than Overlap nozzle : Head drive frequency is twice as much as overlap nozzle.

Usually, the firmware changes over automatically these full overlap Micro-Weave, Part line Overlap Micro-Weave, and ordinal Micro-weave according to the selection of resolution. Also, when these three printing modes are performed by the Stylus Color 600, the printer performs top and bottom margin process in order to control the overprinting volume as little as possible.

2.1.1.2 Carriage Mechanism

Carriage mechanism is to drive the carriage with print head mounted from left to right or vice versa. The carriage drive motor in this printer is a 4-phase, 200-pole, stepping motor and is driven by 1-2phase, 2-2phase and W1-2phase drive method. This stepping motor allows the carriage to move freely to the particular positions which is necessary for various operation, such as paper feeding, ink absorbing, flashing, ink exchange and cleaning operations. The tables below shows carriage motor specifications and motor controls at each mode.

Table 2-2. Carriage Motor Specification

Item	Description
Motor type	4-phase/200-pole Stepping motor
Drive voltage Range	42VDC • } 5%
Internal coil resistance	7.8 ohms • } 10%(per phase under 25 • • environment)
Driving speed(frequency) range[csp(pps)]	5(60) • ` 340(4080)
Control method	Bi-Pola Drive

Table 2-3. Motor Control at Each Mode

Mode	Driving speed [CSP]	Drive frequency [PPS]	Drive method
High speed skip	340	4080	W1-2, 2-2,1-2phase drive*
Printing(Normal)	200	2400	W1-2phase drive
Printing(SLQ)	100	1200	W1-2phase drive
Capping	80	960	W1-2phase drive
Wiping	40	480	W1-2phase drive
Cap(valve release)	20	240	W1-2phase drive
Withdrawal of cap	5	60	W1-2phase drive

*Note 1): The reason why plural drive methods exist is that following some sequences described below exist in the each mode and stable carriage operation and printing are performed individually by different drive methods. This drive method is especially necessary for high speed skip.

- Acceleration 1 mode • " • Acceleration 2 mode • " • Deceleration 1 mode • " • Deceleration 2 mode

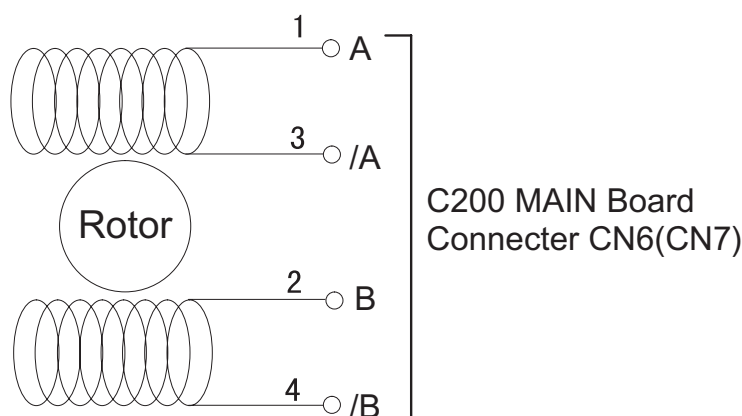

Figure 2-7.CR(PF/Pump) Motor Internal Block Diagram

EPSON Stylus Color 600

The table below shows W1-2 phase drive sequence at each steps when the rotor of carriage motor makes one rotation. In the Stylus Color 600, in addition to a function that printing is performed with W1-2 drive phase, high speed skip mode which is a function to skip over the blank from the end of the printing data to the next data starting point with high seed can be also performed by 2-2 and 1-2 phase drive. W1-2 phase requires 4 times as much steps as 2-2 phase drive, calculating 2-2 phase as standard. By using this method, it becomes possible to supply constant stable torque to the motor. As a result, it also became difficult to be influenced by vibration from the printer mechanism during printing.

Table 2-4. Motor Drive Sequence(W1-2 phase drive)

Sequence Number	Phase A				Phase B			
	Phase a	10a	I1a	Current Duty	Phase b	10b	I1b	Current Duty
0	0	1	0	+2/3	0	1	0	+2/3
1	0	0	1	+1/3	0	0	0	+1
2	X	1	1	0	0	0	0	+1
3	1	0	1	-1/3	0	0	0	+1
4	1	1	0	-2/3	0	1	0	+2/3
5	1	0	0	-1	X	0	1	+1/3
6	1	0	0	-1	1	1	1	0
7	1	0	0	-1	1	0	1	-1/3
8	1	1	0	-2/3	1	1	0	-2/3
9	1	0	1	-1/3	1	0	0	-1
10	X	1	1	0	1	0	0	-1
11	0	0	1	+1/3	1	0	0	-1
12	0	1	0	+2/3	1	1	0	-2/3
13	0	0	0	+1	1	0	1	-1/3
14	0	0	0	+1	X	1	1	0
15	0	0	0	+1	0	0	1	+2/3

This W1-2 phase drive (or 2W1-2 phase drive) is called Micro-step and is attached with so called $2/3 \cdot E_{Vref}$ or $1/3 \cdot E_{Vref}$ factor, compared with drive current value ($V_{ref}100\%$) which is supplied at 2-2phase drive. This Micro-Step allows the rotor to have delicate rotation. In the 2-2 phase drive method, it is usually required to take 4-step sequence in order to rotate the rotor once. However, in case of W1-2 phase, it is required to take 16-step sequence(in the table 2-4, sequence 0 ~ 15) which is 4 times more than 2-2 phase method to do that. Also, in case of 2W1-2 phase drive which can be seen in the Stylus Color etc., it takes 2-step to rotate the rotor once. The table below shows relation of rotation direction of rotor and carriage proceeding direction.

Table 2-5. Relationship Between Rotor Direction and Carriage Operation

Carriage proceeding direction	Rotation direction of Rotor	Drive method	Proceeding order of sequence
HP • → 80 column direction	Looking from rotor output side, clockwise direction	2-2, 1-2, W1-2 phase	Sequence No.0 • → 15
80 column • → HP direction	Looking from rotor output side, counterclockwise direction	2-2, 1-2, W1-2 phase	Sequence No.15 • → 0

The figure below shows carriage mechanism. The print head as a core of the printing mechanism is stored in the carriage unit. This print head keeps the tilt of print head in flexible and adjustable structure by moving the adjustment lever up and down by the tilt adjustment mechanism. (Refer to chapter 4 for more details) Also, parallelism adjustment lever is mounted on the left and right side of carriage guide shaft and it adjusts parallelism degree between platen and shaft when this shaft is installed to the printer mechanism. After this adjustment is completed and operate PG adjustment lever, it becomes possible to change the space between platen surface and print head surface into 2 phases; either 1.1mm to 1.8mm. It is possible to vary the space between platen surface and print head by rotating the axis of carriage guide shaft which itself is decentralized, with the operation of PG lever. This is the mechanism that user can adjust the appropriate PG value by himself according to the paper thickness or any other environmental conditions such as paper curl.

Carriage lock mechanism is to prevent the carriage from being left at uncap position for a long time because of vibration during the printer transport or mishandling by the users. If the carriage is left at uncap position and uncap state of the print head for long time, an ink on the print head surface gradually becomes viscosity. As a result, the nozzle will be unable to discharge an ink. To make matters worse, the holes(crater) of nozzle may be completely clogged by the viscosity ink and it may not be able to return to the normal condition just by cleaning operation. In order to prevent this, printer goes to carriage lock state at the following conditions.

- ❑ **After Power OFF operation:**
 - If the power is turned off on the way of printing or any other performance, carriage lock will be performed in the end after completing initialize operation.
- ❑ **After power ON operation:**
 - After power is turned on and automatic P-On Cleaning is performed, then carriage lock will be performed. P-On Cleaning is an automatic head cleaning that is performed when the power is turned on. The timer IC always calculates printer's power OFF time by the power of lithium battery mounted on the C200 main board. P-on cleaning function automatically selects the cleaning level according to the time which the printer is not in used.
- ❑ **After Eject the paper:**

After Load/Eject button is pressed and the paper is ejected, if the data is not input, the printer performs carriage lock and goes to standby state. However, if the paper is loaded to the printer inside by Load/Eject button, the printer does not perform the carriage lock operation.

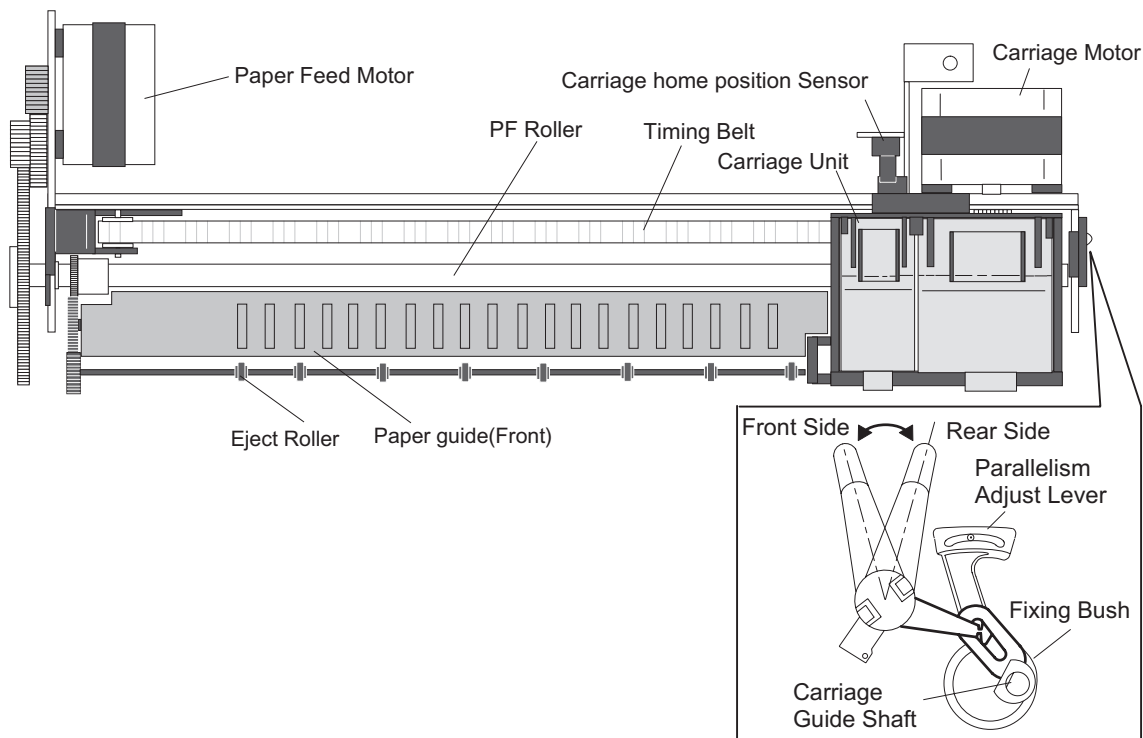

Figure 2-8. Carriage Mechanism(Top Viewing)

2.1.1.2.1 Platen Gap Adjust Mechanism and Parallel adjustment Mechanism

This mechanism can be set by the users and can prevent various problems related to low image density or print with any dirt by changing the positions of PG lever according to the paper types.

Table 2-6. Platen Gap Adjust Lever Setting

Paper	Lever position	PG adjustment value
Normal paper, Coated paper	Front	0 mm (1.1mm between head and platen)
Envelops	Rear	0.9mm (2.0mm between head and platen)

It is a major premise that parallel adjustment is done correctly for the space between head and platen (PG adjustment value above) which can be changed by platen gap adjustment. Parallel adjustment should be done when the serviceman mounts the carriage guide shaft on the printer mechanism during the production process or repair service. In the adjustment, the space between parallel adjustment lever and gauge should be 1.04 mm.

2.1.1.3 Paper Feed Mechanism and Pump Mechanism

Mechanisms that send the paper in the hopper to inside the printer and perform constant paper feed in order to perform printing on the sent paper are called paper feed mechanism as generic name. In the Stylus Color 600, 4-phase, 200-pole hybrid type pulse motor is used in the PF motor as a motive power of the paper mechanism and driving is done at 2-2 and 1-2 phase drive method. This motor is not only used as a power source for paper feed mechanism but also used as power source of pump mechanism which is necessary for print head cleaning. By using this pulse motor, it becomes possible to use high speed driver or intermittent drive for the various paper feeds and pump operations such as paper feed, slight paper feed, high and low speed absorption of pump operations. Following tables (Table 2-7 and 2-8) show PF motor specifications and control method at each mode.

Table 2-7. PF Motor Specification

Item	Description
Motor type	4-phase/200-pole Stepping motor
Drive voltage	42VDC • } 5%
Coil Resistance	7.8 ohms • } 10% (per 1 phase under 25 • • environment)
Drive frequency [csp(pps)]	400-4320Hz
Control method	Bi-Pola Drive

Table 2-8. Motor Control Method at Each Mode

Mode	Drive Method	Drive Frequency [Hz]	Pulse Space (f _{fs})
Paper feed A	2-2 phase	4320	231
Slight paper feed	1-2 phase	400	2500
Slight paper feed	1-2 phase	2400	417
High speed attraction of pump	2-2 phase	4100	243
Low speed attraction of pump	1-2 phase	1800	555
Low speed paper feed	1-2 phase	1200	833
Paper feed B	2-2 phase	3400	294
Paper feed C	1-2 phase	4000	250
Ordinal absorption of pump	1-2 phase	4100	243

Following tables show 1-2phase drive method at PF motor drive and each drive sequence at 2-2phase drive method.

Table 2-9. 1-2 Phase Drive Method

Step No.	Clockwise		Counter clockwise	
	Phase A	Phase B	Phase A	Phase B
1	+2/3	+2/3	+2/3	+2/3
	0	+1	+1	0
2	-2/3	+2/3	+2/3	-2/3
	-1	0	0	-1
3	-2/3	-2/3	-2/3	-2/3
	0	-1	-1	0
4	+2/3	-2/3	-2/3	+2/3
	+1	0	0	+1

Table 2-10. Drive Sequence at 2-2 Phase Drive

Step No.	Clockwise(CW)		Counter clockwise(CCW)	
	A	B	A	B
1	+2/3	+2/3	+2/3	+2/3
2	-2/3	+2/3	+2/3	-2/3
3	-2/3	-2/3	-2/3	-2/3
4	+2/3	-2/3	-2/3	+2/3

EPSON Stylus Color 600

Papers on the ASF (auto-sheet-feeder) supplied by the user are carried to the printer inside by paper pick up sequence. Unlike the previous models, ASF of Stylus Color 600 has multi feed prevention mechanism. Following explains this function and figure below shows its mechanism.

[1. Multi feed prevention mechanism]

When the Load/Eject button is pressed, reversed rotation of PF motor is performed. The return lever resets papers which are already in the out of stand by position in the stand by position and make it possible to perform stable paper feeding by picking up the paper again.

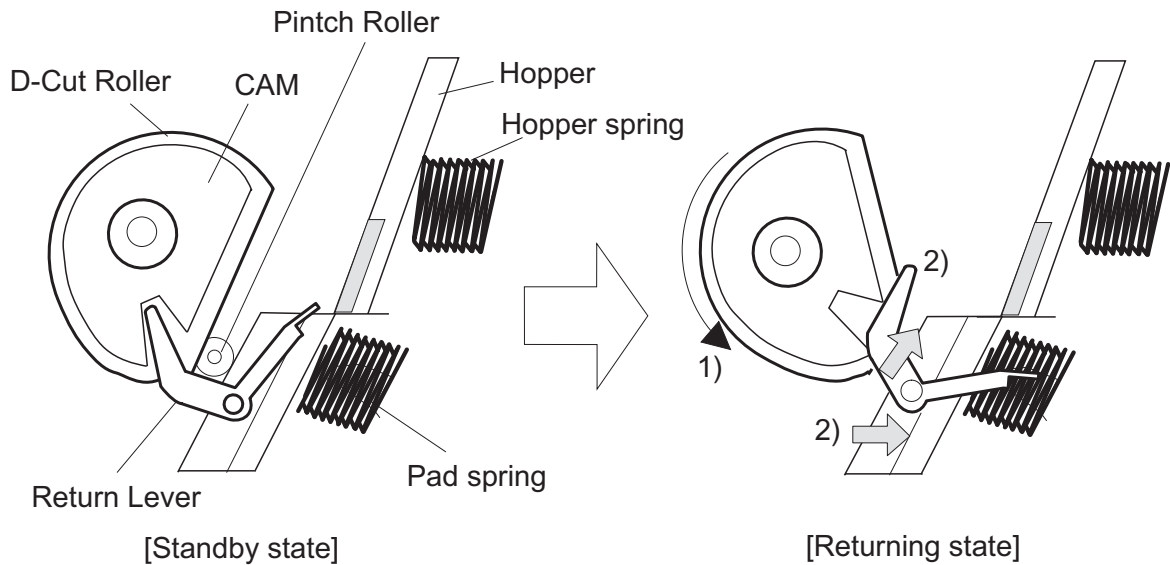

Figure 2-9. Multi Paper Feed Prevention Mechanism

Following explains process of multi feed prevention step by step. Refer to the figure above and confirm its operation.

- [Step 1]** When the load/Eject switch is pressed or printing order is input from the PC, PF motor rotates counterclockwise and makes the CAM rotate towards direction of 1 in the figure above.
- [Step 2]** When the CAM covers the notch by the return lever, that position is considered as home position, being monitored by ASF sensor.
- [Step 3]** When the CAM rotates toward 1 in the figure above, the return lever is pushed by the notch of CAM and falls towards 2. At this time, the return lever moves to direction 3 by this motion, and push down the pad which is waiting in the below part. At this time, friction of pinch roller and pad will be canceled.
- [Step 4]** The papers which are out of stand by position by the previous paper feed motion are returned to the paper stand by position by flip over strength of return lever. After this, PF motor rotates clockwise and the printer goes to pick up sequence.

In the paper pick up mechanism of Stylus Color 600, same mechanism as Stylus Color IIs/820 are applied. This mechanism changes adjoined lines of gear by colliding trigger lever with carriage unit and convey the motive power on the platen to the ASF side(paper roller). The figure below shows mechanism with explanation.

[2. Paper pick up mechanism]

When the Load/Eject switch is pressed or printing order is input, the carriage unit moves until the left edge and collides with paper pick up trigger lever. When the carriage collides with this trigger level, a planetary gear located on the same axis is also pushed at the same time and conveys the motive power on the platen to the adjoined gear line side for ASF drive.

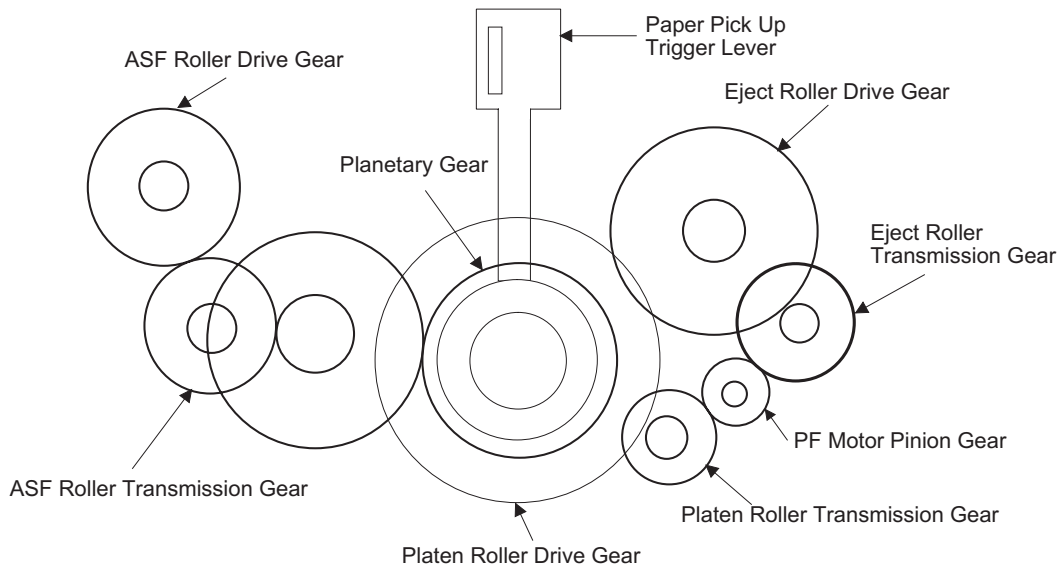

Figure 2-10. Paper Pick Up Mechanism

[3. Paper feed mechanism]

After papers in the ASF receive controls from pick up and multi feed prevention mechanism, they are sent to the printer inside. The papers picked up by paper roller in the ASF goes to between platen and roller support. Also, the eject roller pushes out the paper completely until the end and the roller support drops the paper in the eject tray. The eject roller is driven with an eject paper notched roller as pair where is located on the paper eject roller. Paper eject notched roller solves the deflection of paper that is in the between platen eject notched roller and paper eject roller and always keep a certain space between print head and paper surface. The figure below shows paper feed mechanism.

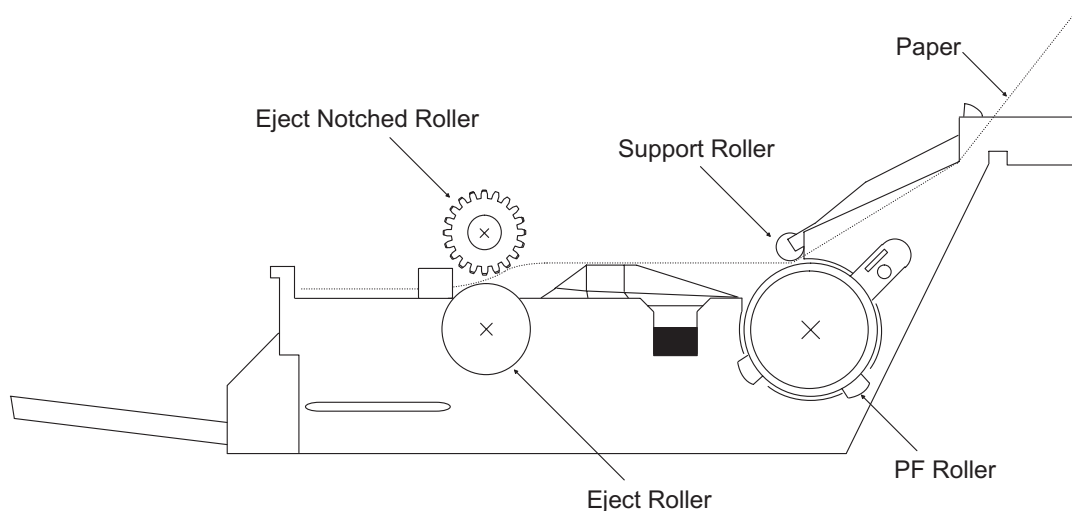

Figure 2-11. Paper Feed Mechanism

2.1.1.4 Ink System

Ink system mechanism consists of 1)cap mechanism, 2)pump mechanism, 3)carriage lock mechanism, 4)waste ink absorber and 5)ink sequence. Out of these mechanism, from 1) to 4) are physical mechanism and parts which are mounted on the printer mechanism and 5) ink sequence is performed automatically by firmware. Also, unlike previous models, since Stylus Color 600 has no engage/disengage mechanism to change over pump mechanism and paper feed mechanism, it is one of the major characteristics that pump and platen are always at work whenever the PF motor is driven. The figure below shows head positions when the ink system and various ink sequence are performed.

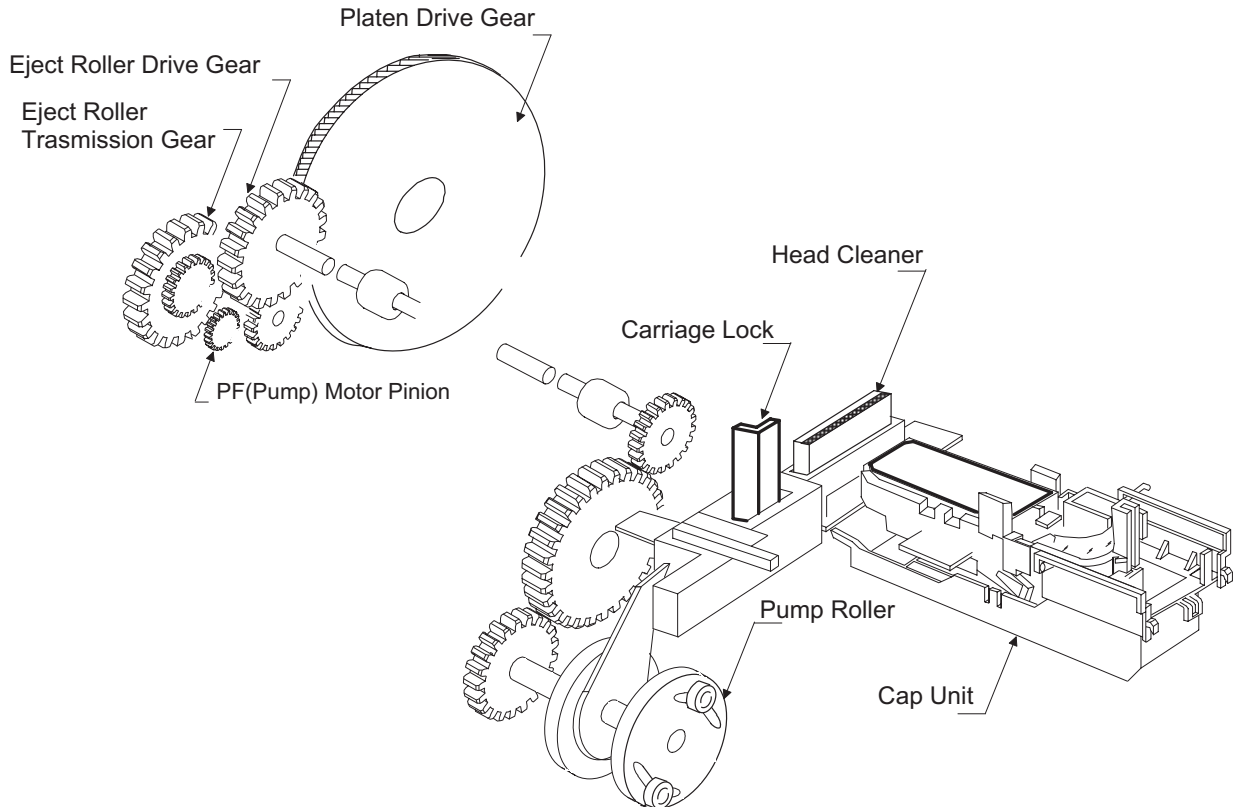

Figure 2-12. Ink System Mechanism

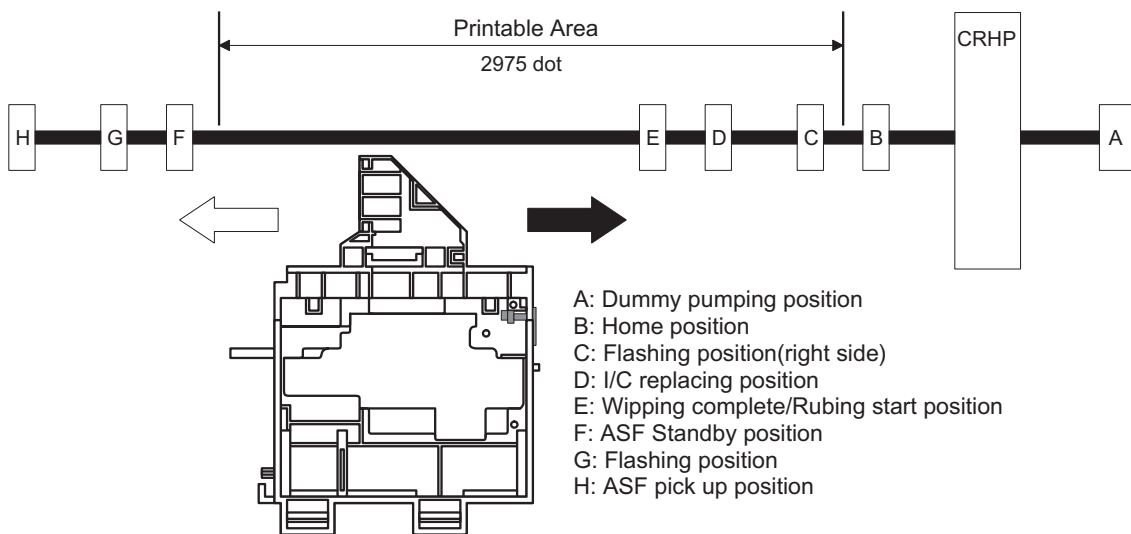

Figure 2-13. Major Ink Sequence Position on the Carriage Mechanism

2.1.1.4.1 Pump, Carriage Lock, Head Cleaner Mechanism

In the Stylus Color 600, there is no switch or mechanism to change over the pump/paper feed mechanism. Therefore, whenever the paper feed/pump motor rotate, pump drive roller in the pump unit inside rotates. However, ink absorption/non ink absorption are separated by the roller rotational direction. Also, even if the pump driver rotates toward ink absorption and the carriage position is in the false absorption position, only driving in the pump mechanism is performed and actual ink attraction is not done. The figure below shows process of conveying motive power to the pump drive roller.

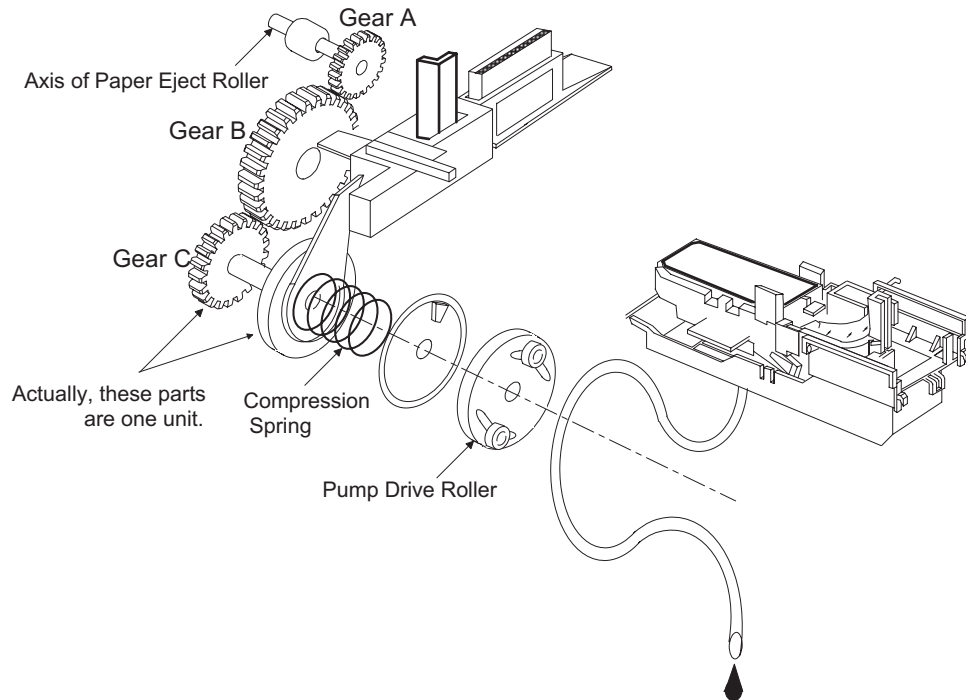

Figure 2-14. Pump Mechanism Power Transmission Process

The process of conveying the motive power to the paper eject roller by rotating the pinion of PF motor is described in figure 2-14. This motive power is conveyed to the Gear C through Gear B. In the figure above, although the lever in order to drive Gear C, carriage lock, head cleaner mechanism is shown separately, it is constructed as one unit. Since the engagement of these two parts depends on the tension of the compression spring, if the lever is burdened, only Gear C and pump roller rotate and no more motive power is conveyed to the lever part.

EPSON Stylus Color 600

The table below shows PF/Pump motor rotational direction and pump system operation.

Table 2-11. Relationship Between Pump Motor Rotation and Pump Operation

PF/Pump motor rotational direction	Pump unit operation
Clockwise(CW) forward rotation	1)Release from the Pump pressure welding 2)Head cleaner reset 3)Carriage lock reset
Counterclockwise(CCW) backward rotation	1)Rotation towards pump pressure welding 2)Head cleaner set 3)Carriage lock set

The figure below shows the pump operation at clockwise and counterclockwise rotation.

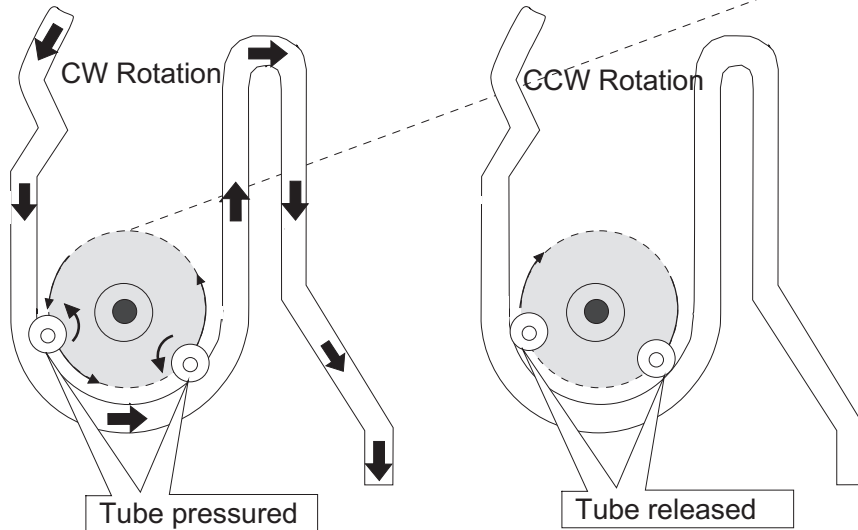

Figure 2-15. Pump Roller Rotation and it's Operation

In the ink absorptive operation such as cleaning, flushing initial ink charge except for printing operation, ink in the ink cartridge drains to the waste ink absorber(pad) through the cap by the pump unit drive. In case of printing and flashing drive, ink is popped out by the PZT in the print head, but in case of absorptive operation such as cleaning and initial ink charge, ink absorption is performed only by the pump drive without PZT drive after the head surface is adhered to the cap. The next page explains cap mechanism and relation between printer operation and cap.

2.1.1.4.2 Cap Mechanism

In the cap mechanism, in order to prevent ink from being thickened on the head surface, it is controlled that the head surface stays adherent to the rubber frame of the cap surface when the power is off. The absorber is spread in the cap and can hold a certain amount of ink which is absorbed from the head without draining it to the waste ink pad. Also, in the bottom of absorber, there are two valves in order to control adhesion of head and cap surface, and one exit to drain ink to the waste ink pad.

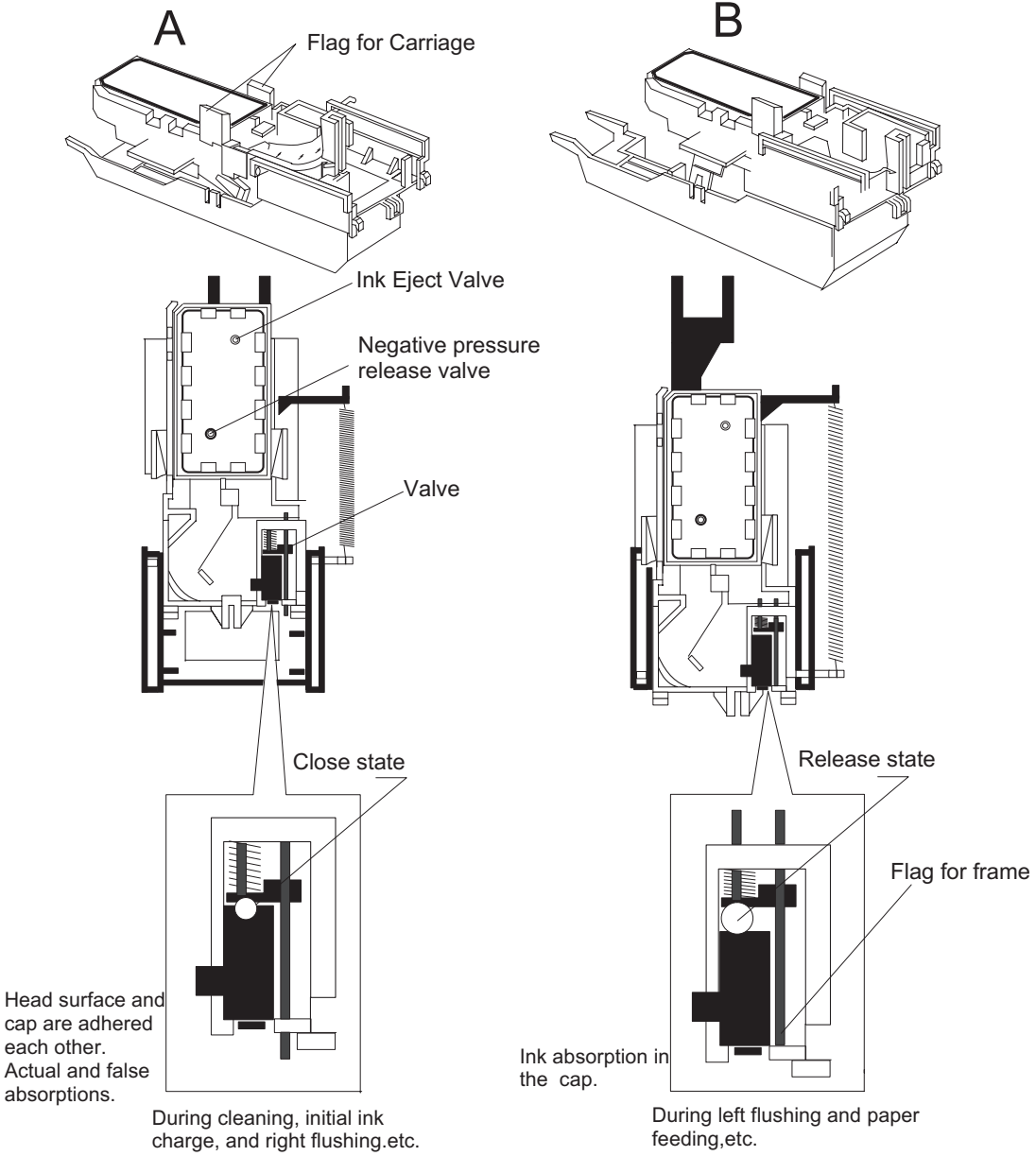

Figure 2-16. Cap Mechanism Operation Principle

If the carriage is out of HP (in this case, in the printable area or paper feed position), the valves on the cap mechanism stay in the position A in the figure above and are always closed. In this condition, the carriage collides with flag, actual ink absorption and slight ink absorption are performed. Also, by moving the carriage to further right side and colliding the flag for opening the valves with the frame, negative pressure is released in the state that head surface and cap are adhered. This makes it possible for ink on the nozzle plate surface to be ready for leaving from the cap in the stable condition.

2.2 Electrical Circuit Operating Principles

Stylus Color 600 contains the following four electric circuit boards.

- C206 PSB/PSE board
- C200 Main board
- Head Driver board
- C206 PNL board

C206 PSB/PSE, C200 board are explained in this section. The head drive board is installed in the head unit on the carriage. The figure below shows major connection of the 3 boards and their roles.

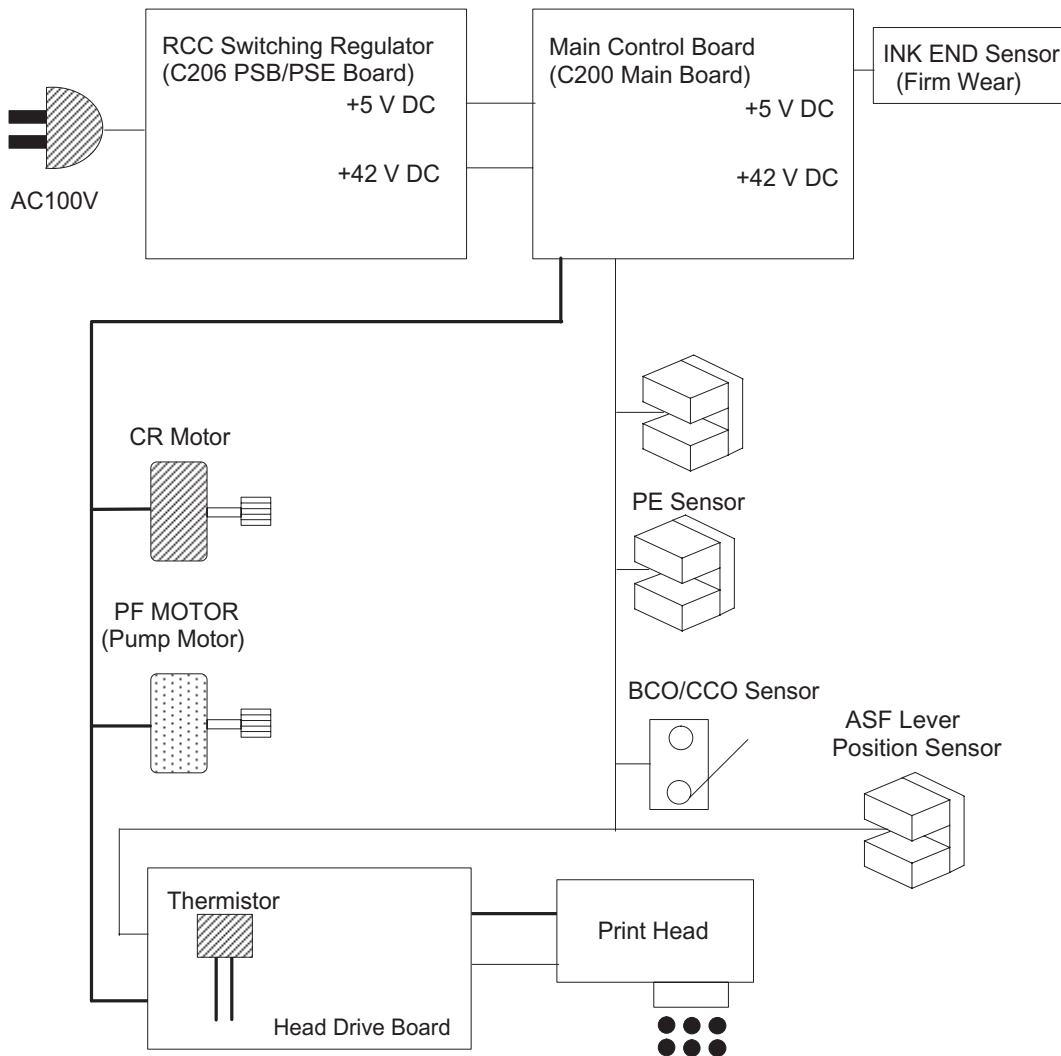

Figure 2-17. Electric Circuit of Stylus Color 600

2.2.1 C206 PSB/PSE Power Board

C206 PSB/PSE board is a power supply board with a RCC switching regulator, which generates +42VDC for drive part and +5VDC for logic part to drive the printer. One of the major characteristic of this board is that the same secondary switch is used as Stylus Color series printer. By using this switch, the following difference can be seen as superficial phenomena compared with products applied with primary switch method, such as Stylus Color IIs, II and Stylus 800/1000 series printer. The table 2-12 below shows application of voltages generated by C206 PSB/PSE board.

- 1) Even if the switch is turned off during the middle of printer operation, since the driving power is turned off after the carriage goes back to the carriage lock position, the possibility of clogging ink nozzle will be decreased.
- 2) If the switch is turned off when the papers in the printer are still being carried except for the papers in the hopper, the same operation mentioned above is performed and the driving power is turned off after the paper is completely ejected.

Table 2-12. Application of DC Voltage

Voltages	Application
+42VDC	<ul style="list-style-type: none"> ■ CR Motor ■ PF/Pump Motor ■ Head driving power supply
+5VDC	<ul style="list-style-type: none"> ■ Power supply for logic control <ul style="list-style-type: none"> ▪ System control signal ▪ Sensor circuit power supply voltage ▪ LED panel drive power supply ▪ Nozzle selector control signal power supply voltage

Figure 2-18 shows block diagram of C206 PSB/PSE board. The process from the input of AC100V to the output of DC42V and 5V is explained below.

- 1) Regardless of the state of power switch(On or OFF), the voltage is always applied in the primary side of the power supply board from the moment or at the state that AC-plug is plugged in. At this time, F1 plays a role of preventing AC100V from coming into the F1. L1 and R1-R2 also prevent high harmonic wave noise generated in the RC circuit filter which consist of C1 • ` C4 and R1 • ` R2 from going out, and eliminate the noise from outside here.
- 2) The AC is full-wave rectified by diode bridge DB1, and converted to $\sqrt{2}$ x AC in voltage by smoothing electrolytic capacitor C11.
- 3) The pressured up direct current makes Q1 On through the starting resistor R31 and starts the primary side of the circuit.
- 4) When the primary side is On state, the energy(current) led by the electromagnetic induction through the trans (T1) does not flow to the secondary side since the diode(D51) on the secondary side is installed in the opposite direction.
- 5) When the energy which is charged in the trans is reaching the saturated state, the voltage which makes the Q1 On becomes weak gradually. At the point that this voltage drops at the certain voltage, C13 absorbs the current in the opposite direction and Q1 is quickly shut off by the resulting sharp drop.
- 6) When the primary side is turned off, the energy charged in the T1 is opened according to the diode(D51) direction which is installed on the secondary side. Basically, 42 V DC is output by these circuit operations and the number of T1 spiral coil .
- 7) +5VDC is generated by pressured down this +42 V DC as power supply. IC51 pressures down the +42 V DC and generates precise +5V DC by chopping off the output, forming the standard santooth waveform by the outer RC integration circuit.

EPSON Stylus Color 600

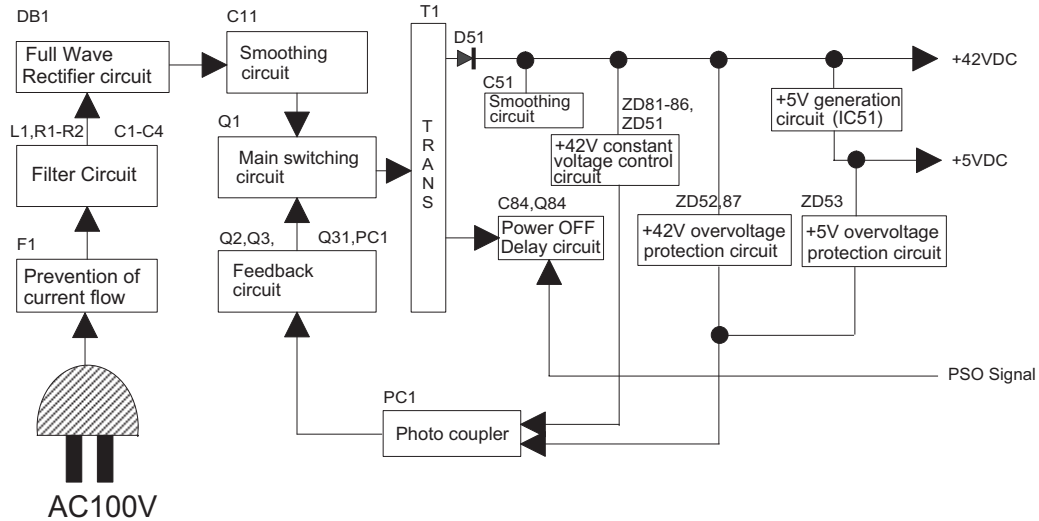

Figure 2-18. C206 PSB/PSE Board Block Diagram

The C206 PSB/PSE board has various control circuits to stop output if malfunction on the power supply board, on the main board or on the duty of printer mechanism happen. Following explains each control and protection circuits.

1) +42V Line Constant Voltage Control Circuit:

The output level of the +42V line is monitored by a detection circuit consisting of seven Zener diodes. This circuit prevents voltage from dropping for constant output voltage.

2) +5V Line Over voltage Protection Circuit:

This protection circuit is in the same line as +42V overvoltage protection circuit is located. The output voltage level of the +5V line is monitored by a Zener diode. This circuit shuts down the circuit operation forcefully when the voltage level exceeds +9V.

3) +42VDC Line Over voltage Circuit

This circuit is in the same line as +5V line over voltage protection circuit is located. The output level is monitored by two Zener diodes. If the voltage level exceeds +48VDC, this circuit stops circuit operation forcefully.

4) +5V Line Constant Voltage/Constant Current Control Circuit:

The output current is monitored by a +5VDC generation switching control IC(IC51), which also monitors the output voltage. This information is input to the internal comparator and stabilizes+5V line. Also, operation of the secondary side switch is explained below.

- 1) When the power is turned on, Q1 repeats ON/OFF automatically along with the increase and decrease of energy on the trans coil at the primary side. While the power is being on, PSC signal is input to the power supply board from the C200 main board.
- 2) This signal turns Q84 on and it becomes possible to discharge energy between 8-9 of T1. At this time, even if the power is turned off, the electrolytic capacitor keeps Q84 on for a while. By this electrolytic capacitor, output is hold at least 30 seconds even after the power is turned off. This time helps the printer to complete the P-Off operation.

2.2.2 C200 Main Board

Various DC voltage generated on the C206 PSB/PSE board is added various signals in order to drive the printer function on the C200 main board, and the drive of CR/PF(Pump) motor and printing head is performed. This control board consists of system part and drive part. In the system part, there are formation and controls of various signals in order to drive the CR/PF(pump) motor, sequence control by input from the sensor circuit, and also output of signal to select appropriate nozzle for the printing head. On the other hand, the drive part has constant current drive by the driver IC for the CR/PF(pump) motor drive and trapezoidal waveform circuit for head drive.

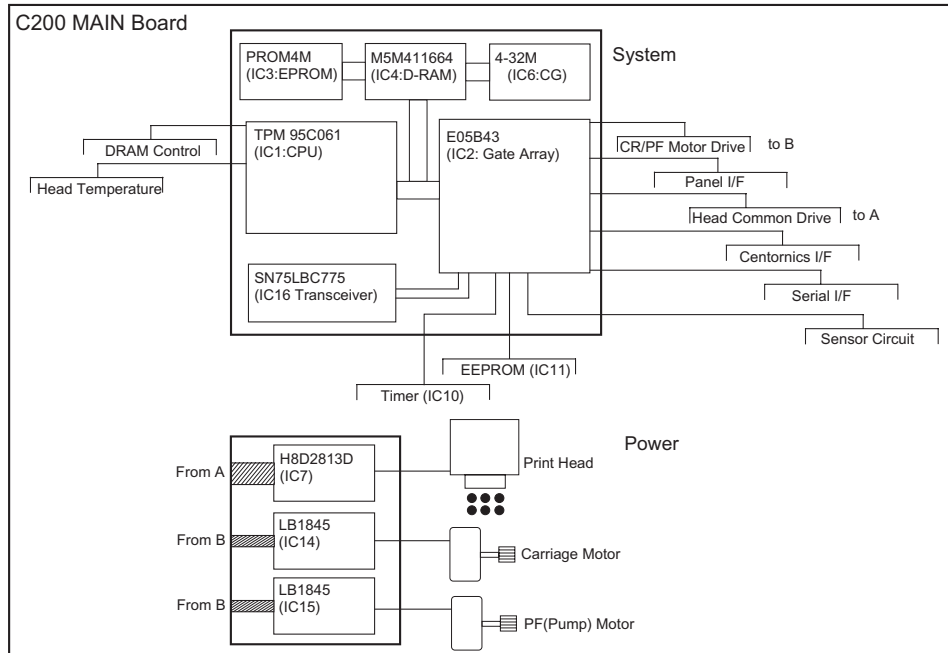

Figure 2-19. C200 Main Control Board Block Diagram

[CPU]

The C200 main board is controlled by a 16-bit CPU(TMP95C061AF) running at 25MHz. Gate array manages most of controls and monitors. Likewise Stylus Color, the D-RAM is applied for RAM which is used as work area for receiving data and developing the data and CPU manages its control such as CE, RAS/CAS controls.

[Gate Array]

E05B43 controls following functions.

- Motor control : Each motor performs data transmission(W1-2 phase) that motives Micro-Step.
- Head voltage control: In the ink jet printers, drive voltage wave form(trapezoidal wave form) in order to drive PZT is formed in the various shapes according to the types of the printers. Therefore, it is necessary to form appropriate drive form for each head. Head voltage control forms necessary waveform for each control signals and outputs them.
- EEPROM control: The correction value to eliminate the error of each printers at the production process is installed in the fixed address of IC. When the power is turned off, the contents set by users is written instantly, and is red to the RAM when the power is turned on.
- Sensor Data: The sensor detects information at the various conditions, which is necessary for the printer operation. The gate array recognizes signals and changes over to the next control.

EPSON Stylus Color 600

- Timer Data: The timer IC that uses lithium battery as power source monitors how long the power is off. When the power is turned on, it is changed to appropriate cleaning level according to the time that the power is off.
- Serial Data: The gate array receives serial data through the transceiver IC.
- Parallel I/F control: With the use of IEEE1284 Nibble mode, it became possible not only to receive the data from the host but also to return various information which the printer possesses to the host.

[Common Driver IC]

The trapezoidal wave form circuit for head drive is became to HIC from the previous discrete structure. Because of this, it is not necessary to adjust the adjustable VR on the board during production process. Various electric charge/discharge control signals are all processed in the HIC.

[CR/PF Motor Drive Circuit]

Constant current drive is performed by the HIC. Out of this, only CR Motor is controlled for Micro-Step control and HIC becomes possible to flow the appropriate current value at each steps. (PF Motor has only 1-2, 2-2phase drive method). Also, bipolar drive is performed on the 4 cables individually. Following pages explain each major control circuit.

2.2.2.1 Reset Circuits

The reset circuit prevents the CPU from running away, which is caused by the unstable voltage in the logic line during the power ON/OFF. Also, this circuit monitors level of power voltage at the overloading or malfunction on the circuit and manages the printer to operate normally, keeping the damage to the printer minimum during the abnormal situations. On the C200 main board, 2 ICs are mounted ; IC for monitoring the voltage level (logic line) and IC for monitoring the voltage level (power line) and both are monitored by the gate array and CPU.

The figure below shows reset circuit block diagram with explanation on the next page.

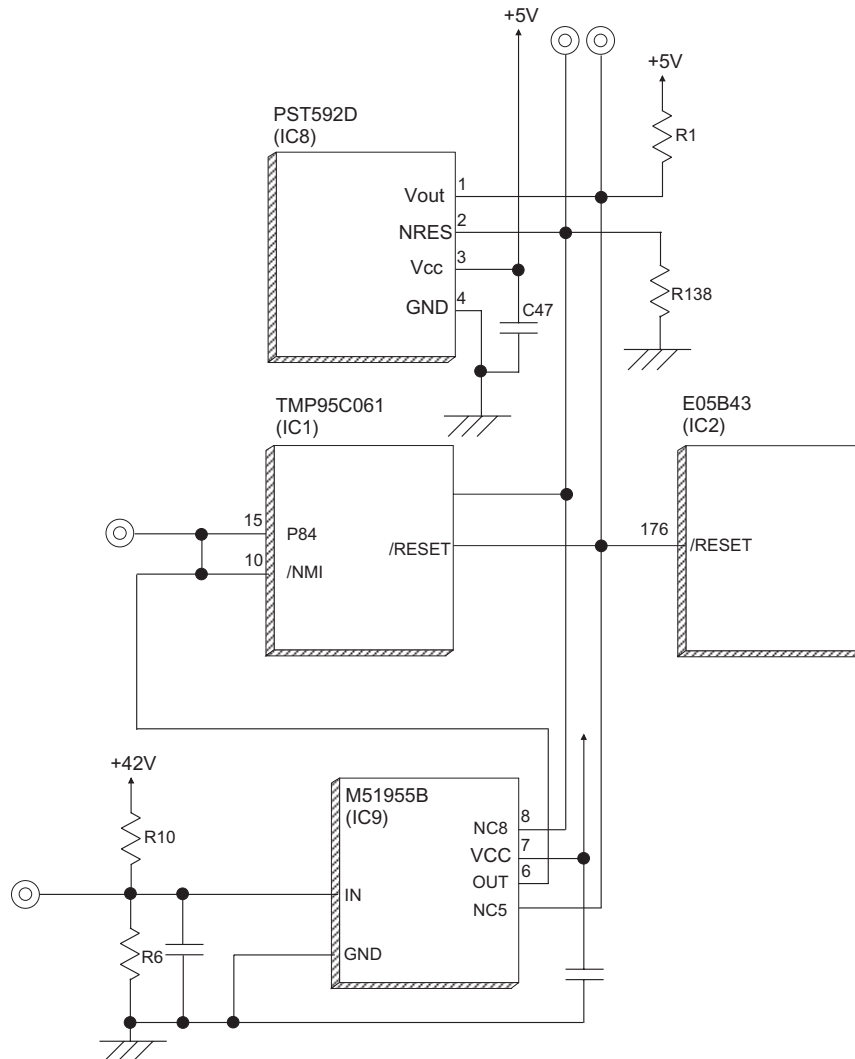

Figure 2-20. Reset Circuit Block Diagram

[PST592(IC8)]

The actual operation of the circuit is to keep outputting Low signal until +5V line goes up to +4.2V when the power is on, and to cancel the reset signal with output of High signal when the voltage goes up more than 4.2V.

[M51955(IC9)]

This IC also performs as monitor on the power line same as the reset IC for logic described above. High/Low is judged at the 33.2V.

[Relation between IC8 and IC9]

Reset signal which is low and output by IC9 is input to the CPU and gate array and system reset operation is performed. Also, this signal is detected on the IC9(IC for reset monitor, power line) and outputs the same Low signal towards CPU/NMI terminal by being input to NC5.

2.2.2.2 Sensor Circuits

The following sensor circuits are mounted in the Stylus Color 600 and selects appropriate operations based on the returned information.

- ASF Sensor: (Photo) An ASF sensor detects the position of return lever when the power is turned on, and causes the paper to be picked up by the pick up roller from the normal initial condition. (Refer to section 2.1.1.3 for detail.)
- PE Sensor: (Photo) A PE sensor determines if there is paper in the printer. Based on the signal form this sensor, a particular paper edge treatment such as Micro-weave printing is performed.
- HP Sensor: (Photo) A HP sensor detects the carriage home position. It is used for managing printing position and cleaning, etc.
- Thermistor Sensor: A thermistor sensor keeps stable printing quality, changing PZT drive voltage(VH) slightly according to changes of environmental temperature.
- Cartridge Sensors: Cartridge sensors are built into the Bk, CMY cartridge on the carriage unit respectively to determine if the cartridge is installed or not when it is exchanged or the power is turned on. In case of Stylus Color 600, the counter is reset at every time the cartridge is removed.

The figure below shows sensor circuit. Out of the data such as EPW with IEEE 1284 Nibble mode to be returned to the host, the data to indicate ink consumption is calculated and managed by the counter of the firmware. Therefore, it is omitted here.

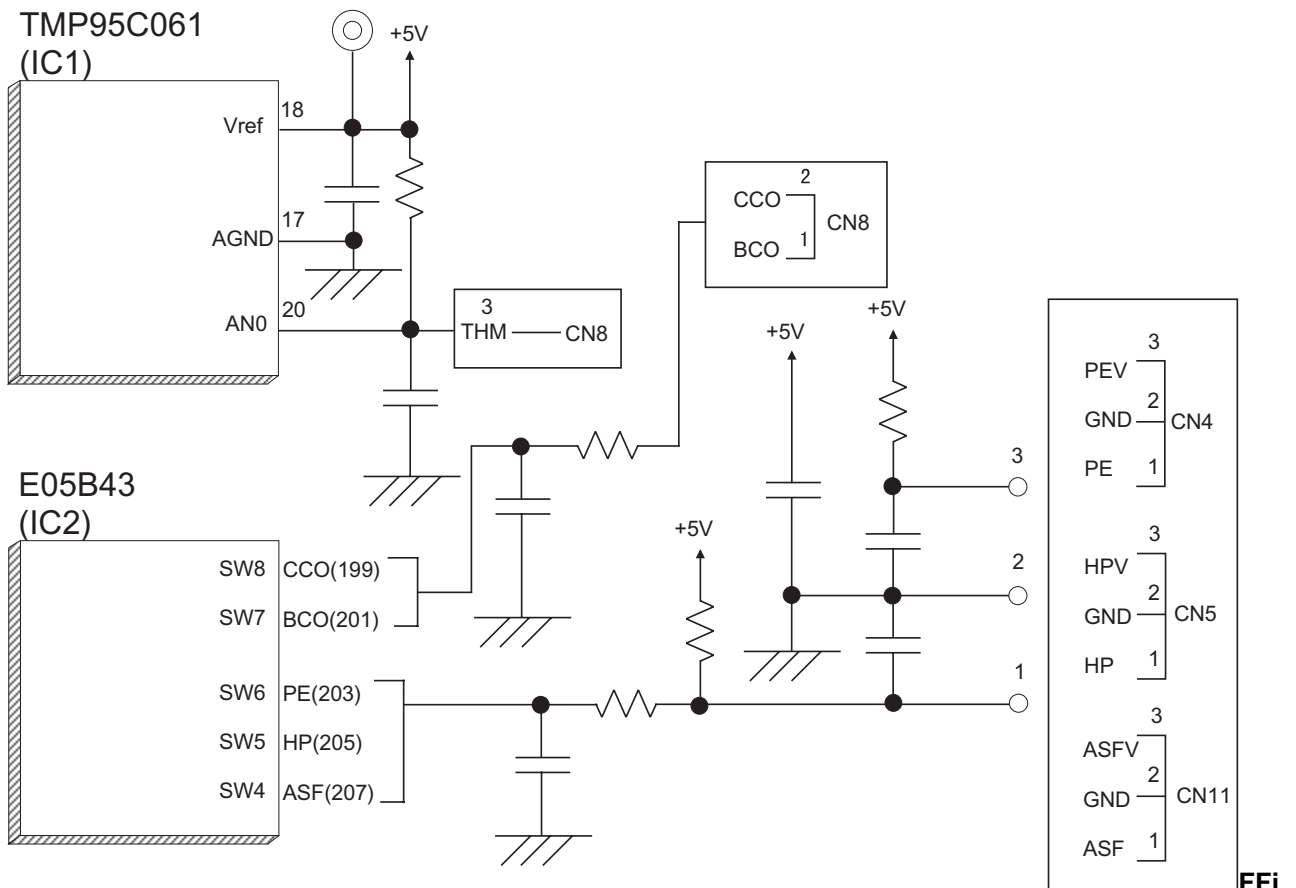

Figure 2-21. Sensor Circuit Block Diagram

2.2.2.3 EEPROM Control Circuits

The EEPROM of Stylus Color 600 has following contents. Gate array E05B43(IC2) controls operations of reading data when the power is on and writing data when the power is off.

- Ink consumption(Bk, CMY)
- CL counter(Various cleaning operations that are previously done are memorized)
- Destination information
- Information of various adjustment values(Bi-D, VH voltage, etc.)
- CPSI pass word
- Other various setting values by the user

EEPROM is connected to the Gate array by 4 lines and performs following functions. The figure below shows EEPROM control circuit.

- CS : Chip selection signal
- CK : Data synchronism clock pulse
- DI : Data writing line(serial data) at power off.
- DO : Data reading line(serial data) at power on.

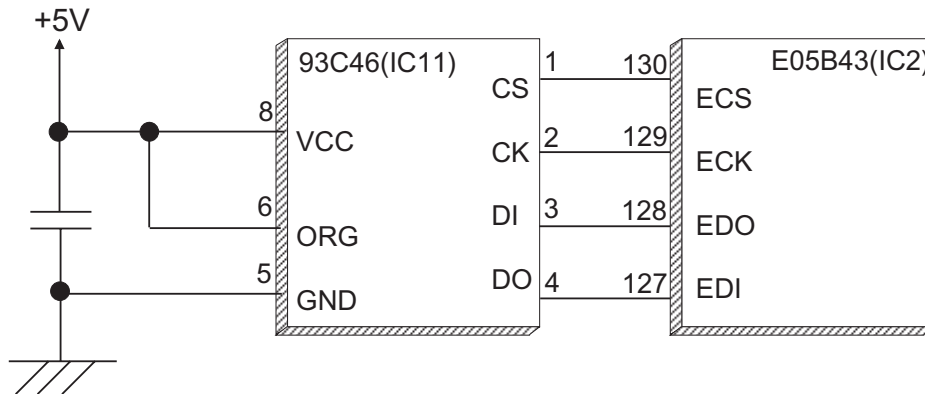

Figure 2-22. EEPROM Circuit Block Diagram

2.2.2.4 Timer Circuit

The lithium battery is mounted on the C200 main board and calculates how long the printer is not in used. The timer IC(IC10) starts counting with oscillation motivated by the CR3 using this battery as a power source. The figure below shows connection of the Timer circuit.

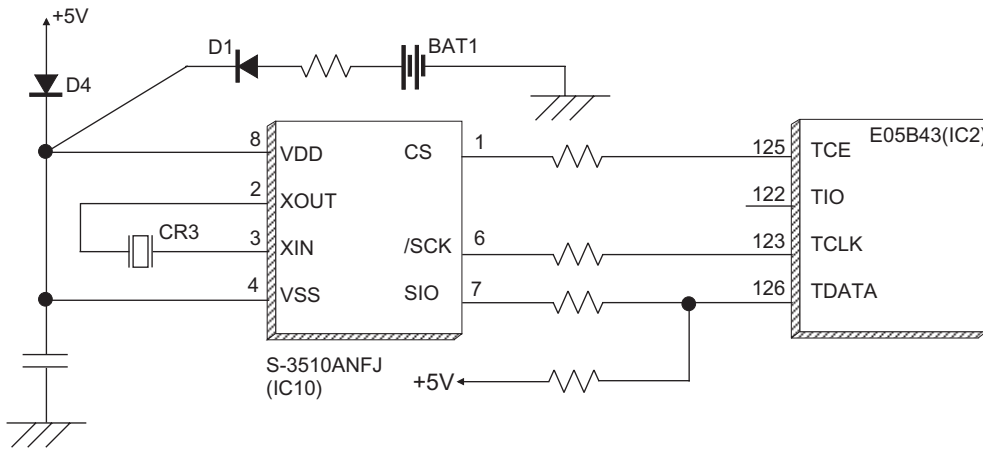

Figure 2-23. Timer Circuit Block Diagram

The followings explain about operation of this circuit.

- When the printer is on, power is supplied to the Timer IC by applying +5V quickly through the D4.
- This power is also used for the power to oscillate the outer CR3. The oscillation wave form is input to XIN terminal.
- Since the oscillation wave form of CR1 is analog waveform, it is processed into the pulse form in the Timer IC.
- When the printer is turned on, the Timer IC outputs power off time as serial data to the gate array.
- Once the printer is turned off, 3VDC of BAT1(lithium battery) is supplied as power source for the Timer IC through D1.
- Since +5V at the power on is higher than +3V of the lithium battery, the power is not being consumed from the lithium battery.

2.2.2.5 DRAM Control

In the Dynamic RAM control, output and formation of CAS and RAS control signals become necessary in addition to the output of CS signal. The CPU TMP95C061AF not only controls that but also perform the output of CS signal of P-ROM. Refresh timing is performed in the CAS Before RAS.

2.2.2.6 Print Head Control Circuit

The print head control circuit of Stylus Color 600 has following characteristics.

- Common waveform circuit became one HIC.
- Micro-vibration mode is added.(when the CR motor is accelerating)
- High speed drive 14.4KHz (trapezoidal wave form)
- Enhanced Nozzle configuration (resolution in the vertical direction)90dpi (However, black nozzle is 2 lines structure)

Also, Stylus Color 600 has Micro-dot control as dot shooting control. There are total three dot shooting controls on this printer.

- Normal Dot mode(Single Firing)
- Normal Dot mode(Dual Firing)
- Micro Dot mode
- Micro-Vibration(Not printed)

The control circuit is considered as two divided parts; 1) trapezoidal wave form generation circuit (common drive circuit) to drive PZT in the head, and 2) Nozzle-selector drive circuit to determine which nozzle should be used. The Nozzle-Selector is attached to the head unit just like the previous models. The common drive circuit is became as HIC and mounted on the C200 main board.

[Common drive circuit]

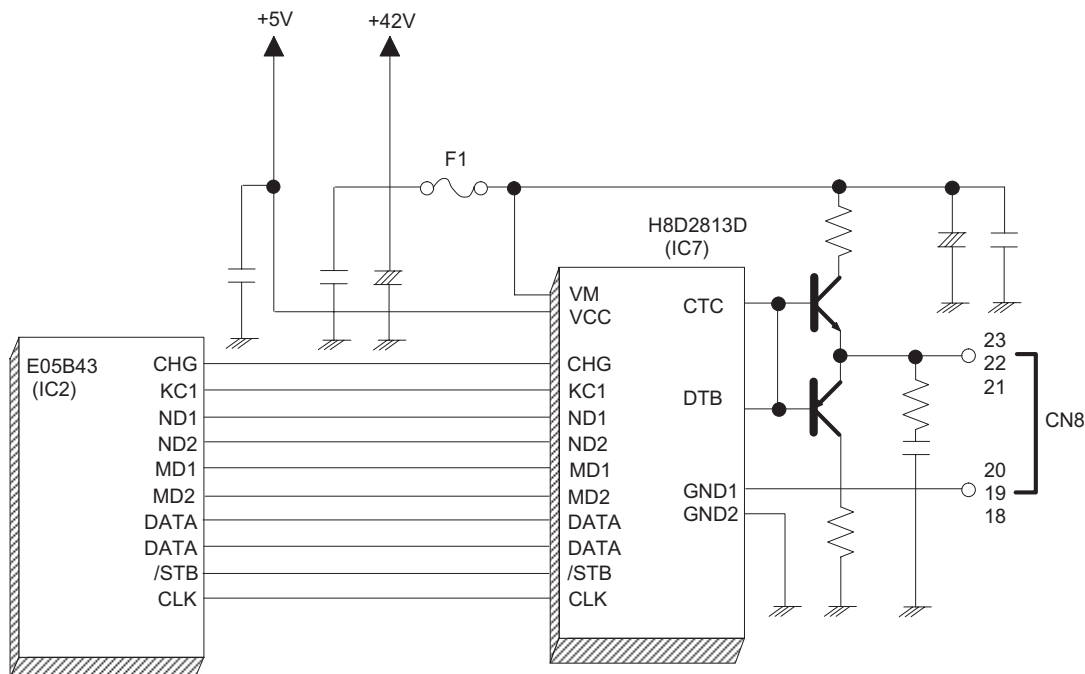

Figure 2-24. Print Head Control Circuit Block Diagram

The shape of trapezoidal wave form will be different according to the printing operation, slight vibrations at the non-printing nozzle and waiting condition. However, IC7(H8D2813) generates all wave forms as drive wave forms by resistance(electric) welding control of common voltage drive control signal that is output from the IC2(E05B43) in the figure above.

Table 2-13. Specifications of H8D2813 Operation

Item	Contents
Power Voltage	42.0 ± 5% Starts supplying after 5V rises and be stabilized./ Stops supplying before +5V drops.
Final drive element	2SC3746(for charging), 2SA1469(for discharging)
Reset Operation	Off on the both charging and discharging sides. Supplies drive power source.

This common voltage trapezoidal wave form can be observed anytime after the +5V rises even if there is printing data or not. (Q7:3-pin, or Q9:3-pin and GND on the C200 main board)

EPSON Stylus Color 600

[Nozzle Selector Drive Circuit]

In order to motivate the print head to carry out printing, it is necessary to transmit the print data to the appropriate nozzles, which becomes direct signals to drive PZT. This data transmission is performed by the serial transport method, however the data output for each black and CMY head is transmitted by the parallel method. The figure below shows data transmission circuit.

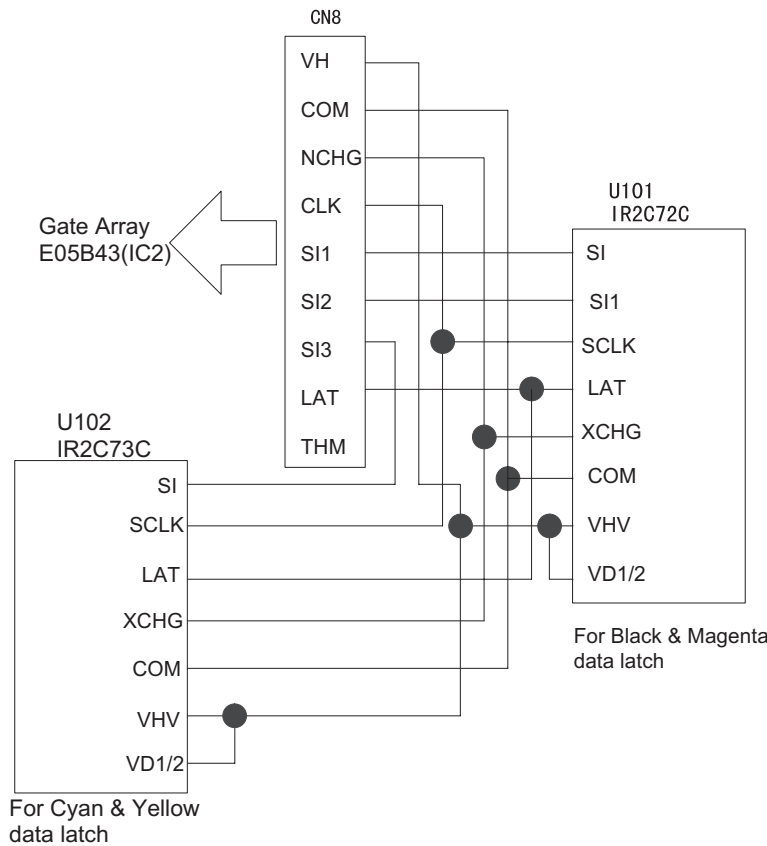

Figure 2-25. Nozzle Selector Circuit Block Diagram

CLK(Clock) pulse considered as source of serial communication is commonly used for both black and CMY. The serial data transmits data as 64-Clock unit, synchronizing with this pulse. After the data transmission of 64-Clock is completed, LAT(Latch) signal is activated and is hold temporarily in the IR2C72C(U101) At this time, since the number of nozzle for Color head is fewer(21-nozzles) and different from the ones for black head, 0 is transmitted forcefully for the data for 43 nozzle (64-21=43).

After the data transmission by the nozzle selector(IR2C72C, IR2C73C) is completed and a certain time passes, trapezoidal wave form generated by the common drive circuit once sends electric current to the PZT for the proper nozzles which are determined in the nozzle selector circuit. This motivates PZT and ejects the ink in the cavity. The figure below shows normal dot data transmission timing in order to from 1-dot.

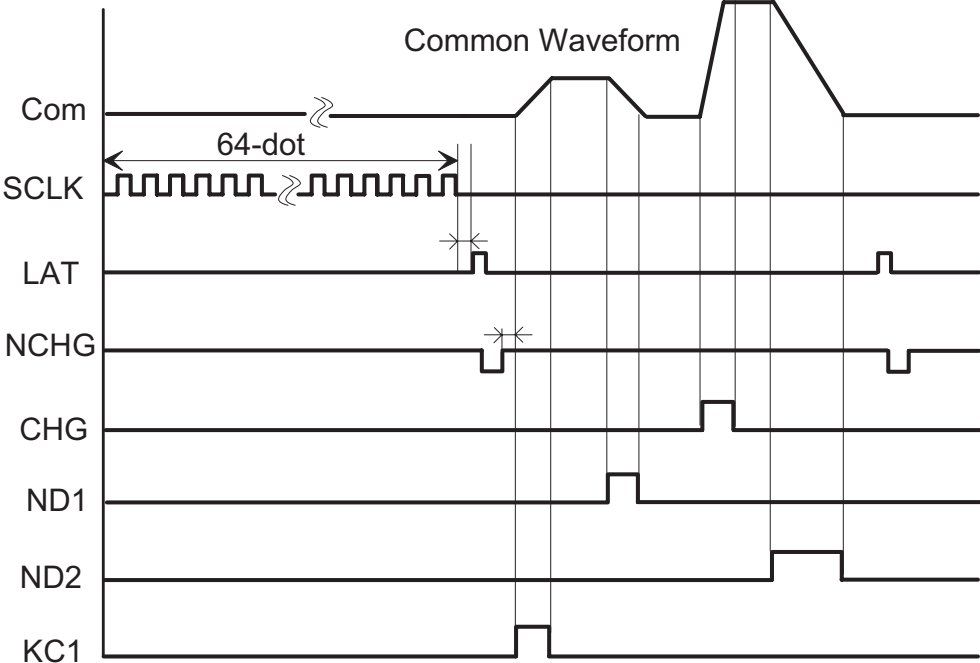

Figure 2-26. Common Drive Circuit Block Diagram

2.2.2.7 PF(Pump) Motor Drive Circuit

IC15(UDN2917) is used for driving PF(Pump) motor. In the IC, Bi-pola drive PWM current control type is performed, making it possible to provide stable current to each phase of motor. Also, it makes possible to change over the reference voltage as drive current settings by making 3 combinations(100%,66% and 33%), using 4 current setting ports(input). (Refer to 2.1.1.3 for motor and details about sequence) However, firmware does not drive Micro-step in the Stylus Color 600. The figure below shows the block diagram of Unlike using Uni-Pola drive, there is no cable for GND in the motor since Bi-Pola drive is performed in the PF motor.(Refer to section 2.1.1.2 since carriage motor interior connection diagram has the same connection as the PF motor's phase connection. This helps to understand the reason why the direction of current is controlled freely in each phase by the combinations of high/low control signals.

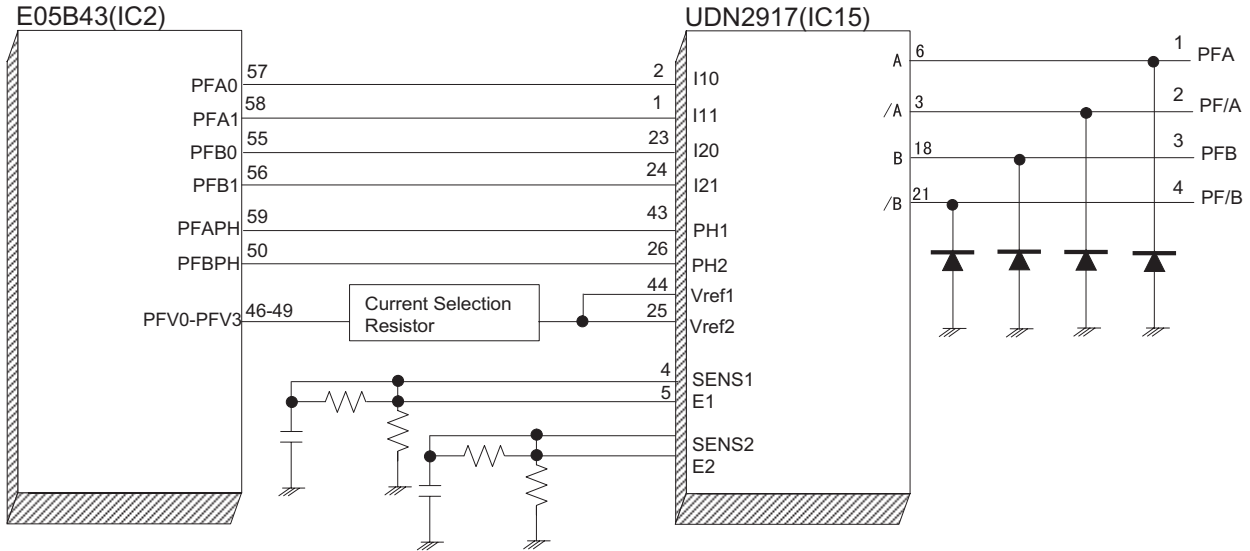

Figure 2-27. PF(Pump) Motor Circuit Block Diagram

The current control is performed by output port(46~49 pin) of E05B43(IC2), its outer resistance circuit and driver IC15(UDN2917). First, firmware possesses 16 ways of current values as current table out of combinations made by 5 resistance which are connected to the output ports(46~49 pin) in the gate array. On the other hand, signals which are output by combination of these resistance's on/off are input in the 25 and 44 pins. HIC is driven at the same standard voltage for each A and B phase.

Actual on/off control to send electricity through the motor is performed by the process that SEN1 and SEN2 terminals (2 and 13 pin) detect the input signal from the gate array which is monitored by the interior comparator, confirm the current that actually flew the phase as current value again and perform the feed back to the on/off. The figure below shows relation between input signal to the driver IC and motor control.

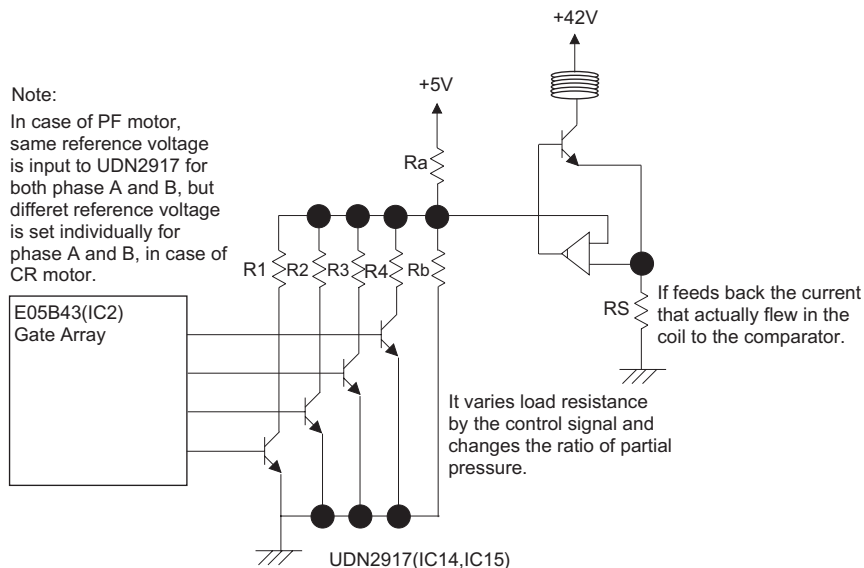

Figure 2-28. PF(Pump) Motor Driver Internal Block Diagram

2.2.2.8 CR Motor Drive Circuit

In the CR motor, the same UPD2917(IC14) as the PF motor has used. In the IC, Bi-pola drive PWM current control type is performed, making it possible to provide stable current to each phase of motor. Also, it makes possible to change over the reference voltage as drive current settings by making 3 combinations(100%, 66% and 33%), using 4 current setting ports(input). (Refer to 2.1.1.3 for motor and details about sequence) In the carriage motor, firmware supports the micro-step driving in the Stylus Color 600. The figure below shows carriage motor drive circuit.

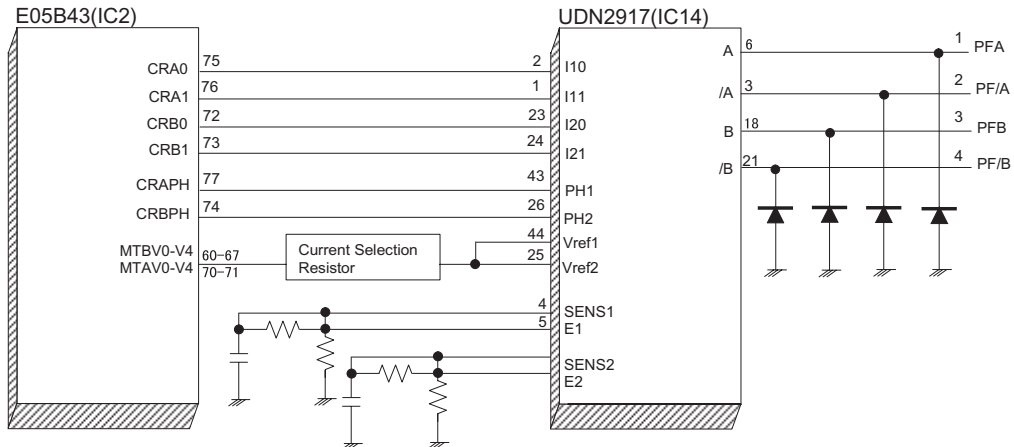

Figure 2-29. Carriage Motor Circuit Block Diagram

Unlike using Uni-Pola drive, there is no cable for GND in the motor since Bi-Pola drive is performed in the CR motor. (Refer to section 2.1.1.2 since carriage motor interior connection diagram has the same connection as the PF motor's phase connection. This helps to understand the reason why the direction of current is controlled freely in each phase by the combinations of high/low control signals.

The current control is performed by output port(60 ~ 67 / 70 ~ 71 pin) of E05B43(IC2), its outer resistance circuit and driver IC14(UDN2917). First, 10 resistance which are connected to the output port of the gate array divide each current values of phase A and B in the CR motor.

The firmware possesses 16 different ways of current values individually as current table out of combinations made by 5 resistance which are connected to the output ports(46 ~ 49 pin) in the gate array. On the other hand, signals which are output by combination of these resistance's on/off are input independently in the 25 and 44 pins. HIC is driven at the different standard voltage for each phase A and B.

Actual on/off control to send electricity through the motor is performed by the process that SEN1 and SEN2 terminals (2 and 13 pin) detect the input signal from the gate array which is monitored by the interior comparator, confirm the current that actually flew the phase as current value again and perform the feed back to the on/off. (Refer to before page since it is same as the one of PF motor)

Chapter 3

Disassembly and Assembly

3.1. OVERVIEW	3-1
3.1.1. Precautions for Disassembling the Printer.....	3-1
3.1.2. Specification for Screws.....	3-2
3.1.3. Tools	3-2
3.1.4. Work Completion Check	3-3
3.2. DISASSEMBLY AND ASSEMBLY	3-4
3.2.1. Housing Removal.....	3-5
3.2.2. Circuit Boards Removal.....	3-6
3.2.3. Control Panel Removal	3-8
3.2.4. Waste Ink Pad Assembly Removal	3-9
3.2.5. Disassembling the Printer Mechanism	3-10
3.2.5.1. Printhead Removal.....	3-10
3.2.5.2. Pump Assembly and Cap Assembly Removal	3-12
3.2.5.3. CR Motor Assembly Removal.....	3-14
3.2.5.4. PF Motor Assembly Removal	3-16
3.2.5.5. ASF Assembly Removal.....	3-18
3.2.5.5.1. ASF Disassembly	3-20
3.2.5.5.2. Pick-Up Roller Assembly Removal.....	3-21
3.2.5.6. Carriage Assembly Removal	3-22
3.2.5.7. PF Roller Assembly Removal	3-24
3.2.5.8. PE Sensor Assembly Removal	3-26
3.2.5.9. HP Sensor Assembly Removal.....	3-27

3.1 OVERVIEW

This section describes procedures for disassembling the main components of EPSON Stylus Color 600. Unless otherwise specified, disassembly units or components can be reassembled by reversing the disassembly procedure. Therefore, no assembly procedures are included in this section. Precautions for any disassembly or assembly procedure are described under the heading "WORK POINT". Any adjustments required after disassembling the units are described under the heading "REQUIRED ADJUSTMENT".

3.1.1 Precautions for Disassembling the Printer

See the precautions below when disassembling or assembling EPSON Stylus Color 600.

WARNING

- ☑ *Disconnect the power cable before disassembling or assembling the printer.*
- ☑ *Wear protective goggles to protect your eyes from ink. If ink gets in your eye, flush the eye with fresh water and see a doctor immediately.*
- ☑ *If ink comes into contact with your skin, wash it off with soap and water. If irritation occurs, contact a physician.*
- ☑ *A lithium battery is installed on the main board of this printer. Be sure to observe the following instructions when servicing the battery:*
 - *Keep the battery away from any metal or other batteries so that electrodes of the opposite polarity do not come in contact with each other.*
 - *Do not heat the battery or put it near fire.*
 - *Do not solder on any part of the battery. (Doing so may result in leakage of electrolyte from the battery, burning or explosion. The leakage may affect other devices close to the battery.)*
 - *Do not charge the battery. (An explosive may be generated inside the battery, and cause burning or explosion.)*
 - *Do not dismantle the battery. (The gas inside the battery may hurt your throat. Leakage, burning or explosion may also be resulted.)*
 - *Do not install the battery in the wrong direction. (This may cause burning or explosion.)*

CAUTION

Danger of explosion if the battery is incorrectly replaced. Replace only with the same or equivalent type recommended by the manufacture. Dispose the used batteries according to government's law and regulations.

ATTENTION

Risque d'explosion si la pile est remplacée incorrectement. Ne remplacer que par une pile du même type ou d'un type équivalent recommandé par le fabricant. Eliminer les piles déchargées selon les lois et les règles de sécurité en vigueur.

CAUTION

- ☑ *Never remove the ink cartridge from the carriage unless manual specify to do so.*
- ☑ *When transporting the printer after installing the ink cartridge, be sure to pack the printer for transportation without removing the ink cartridge.*
- ☑ *Use only recommended tools for disassembling, assembling or adjusting the printer.*
- ☑ *Apply lubricants and adhesives as specified. (See Chapter 6 for details.)*
- ☑ *Make the specified adjustments when you disassemble the printer. (See Chapter 4 for details.)*

3.1.2 Specification for Screws

Table 3-1 lists the abbreviation of screws and its use. Refer to the screw number in the following table to identify the type of screw shown in the disassembly procedures.

Table 3-1. Screw Identification Table

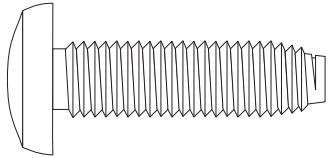
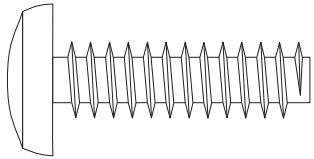
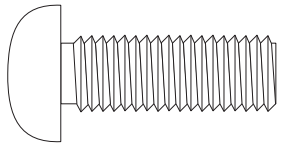
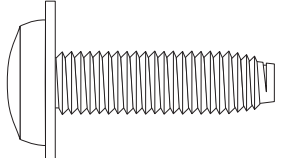
No.	Shape	Name	Standard
1		CBS (Cross/Bind/S-tight screw)	M3x6
2			M3x10
3		CBP (Cross/Bind/P-tight screw)	M3x6
4			M3x10
5			M3x8
6		CP (Cross/Pan-head screw)	M3x4
7		CBS with Washer (Cross/Bind/S-tight screw with washer)	M3x6

3.1.3 Tools

Table 3-2 lists the tools required for disassembling and assembling the printer. Use only specified tools to avoid damaging the printer.

Table 3-2. Required Tools

Name	Availability	EPSON Parts Code
Philips Screw Driver (No.1)	Commercially available	B743800200
Philips Screw Driver (No.2)	ditto	B743800400
Tweezers	ditto	B741000100
Hexagonal Box Driver (5.5mm)	ditto	B741700100

3.1.4 Work Completion Check

If any service is made to the printer, use the check list shown below, to confirm that all works are completed properly and the printer is ready to return to the user.

Category	Item	Check Point	Status
Main Unit	Self-Print Test	Is the printing successful?	<input type="checkbox"/> Checked/ <input type="checkbox"/> Not necessary
	Online Print Test	Is the printing successful?	<input type="checkbox"/> Checked/ <input type="checkbox"/> Not necessary
	Printhead	Are any nozzles broken? (Missing dot)	<input type="checkbox"/> Checked/ <input type="checkbox"/> Not necessary
	Carriage Mechanism	Does it moves smoothly?	<input type="checkbox"/> Checked/ <input type="checkbox"/> Not necessary
		Is there any abnormal noise in its motion?	<input type="checkbox"/> Checked/ <input type="checkbox"/> Not necessary
		Is there any dirt or scratch with the CR guide shaft?	<input type="checkbox"/> Checked/ <input type="checkbox"/> Not necessary
		Is the CR Motor at the correct temperature? (Not too hot)	<input type="checkbox"/> Checked/ <input type="checkbox"/> Not necessary
	Paper Feeding Mechanism	Is paper advance smoothly? *No paper jamming *No paper skew *No multiple feeding *No abnormal noise	<input type="checkbox"/> Checked/ <input type="checkbox"/> Not necessary
		Is the PF Motor at the correct temperature? (Not too hot)	<input type="checkbox"/> Checked/ <input type="checkbox"/> Not necessary
		Is the paper path clear of all obstructions?	<input type="checkbox"/> Checked/ <input type="checkbox"/> Not necessary
Adjustment	Specified Adjustment	Does all the adjustment made correctly?	<input type="checkbox"/> Checked/ <input type="checkbox"/> Not necessary
Lubrication	Specified Point	Does all the lubrication made at specified points?	<input type="checkbox"/> Checked/ <input type="checkbox"/> Not necessary
		Is the amount of lubrication correct?	<input type="checkbox"/> Checked/ <input type="checkbox"/> Not necessary
System	ROM Version	Version (Latest):	<input type="checkbox"/> Checked/ <input type="checkbox"/> Not necessary
Packing	Ink Cartridge	Have brand-new ink cartridges installed correctly?	<input type="checkbox"/> Checked/ <input type="checkbox"/> Not necessary
	Protective Materials	Have all relevant protective materials been attached to the printer?	<input type="checkbox"/> Checked/ <input type="checkbox"/> Not necessary
Other	Attachment, Accessories	Have all relevant items been included in the package?	<input type="checkbox"/> Checked/ <input type="checkbox"/> Not necessary

3.2 DISASSEMBLY AND ASSEMBLY

This section describes the step-by-step disassembly procedures shown in the diagram below.

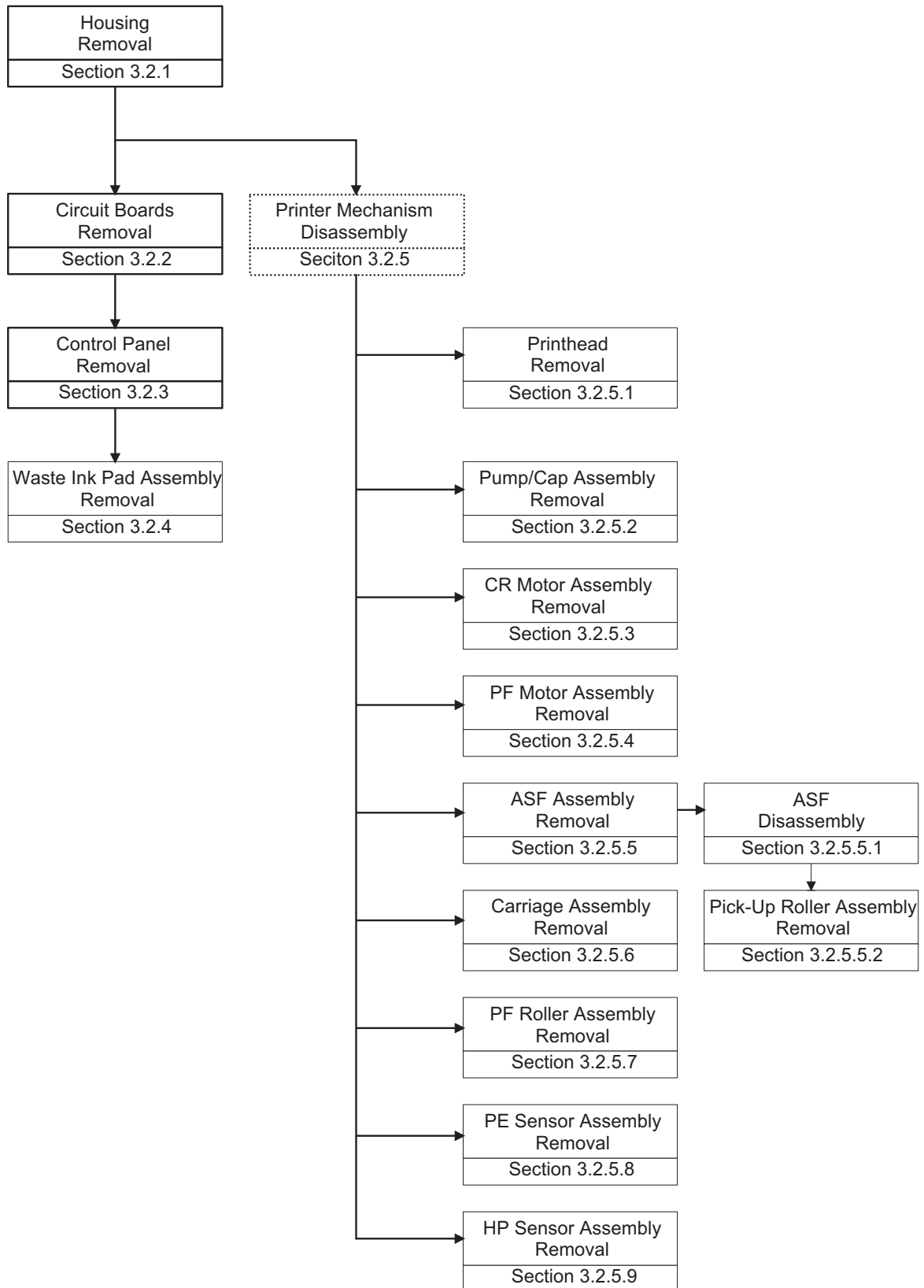

Figure 3-1. Disassembly Flow

3.2.1 Housing Removal

Since the EPSON Stylus Color 600 has no lower housing as previous EPSON printers, the printer mechanism can be taken out by only removing the upper housing.

1. Open the printer cover and set the PG adjust lever on the right-hand side to (+) position.
2. Remove 4 screws (No.2) and remove the upper housing.

WORK POINT

Pull the front end of the upper housing while lifting up the upper housing to remove it.

CAUTION

Be careful not to pinch the cables with the posts of the upper housing when reinstalling it. (Especially with the cables from the motors and doing so causes fatal damage to the mechanism and the electric circuitry.)

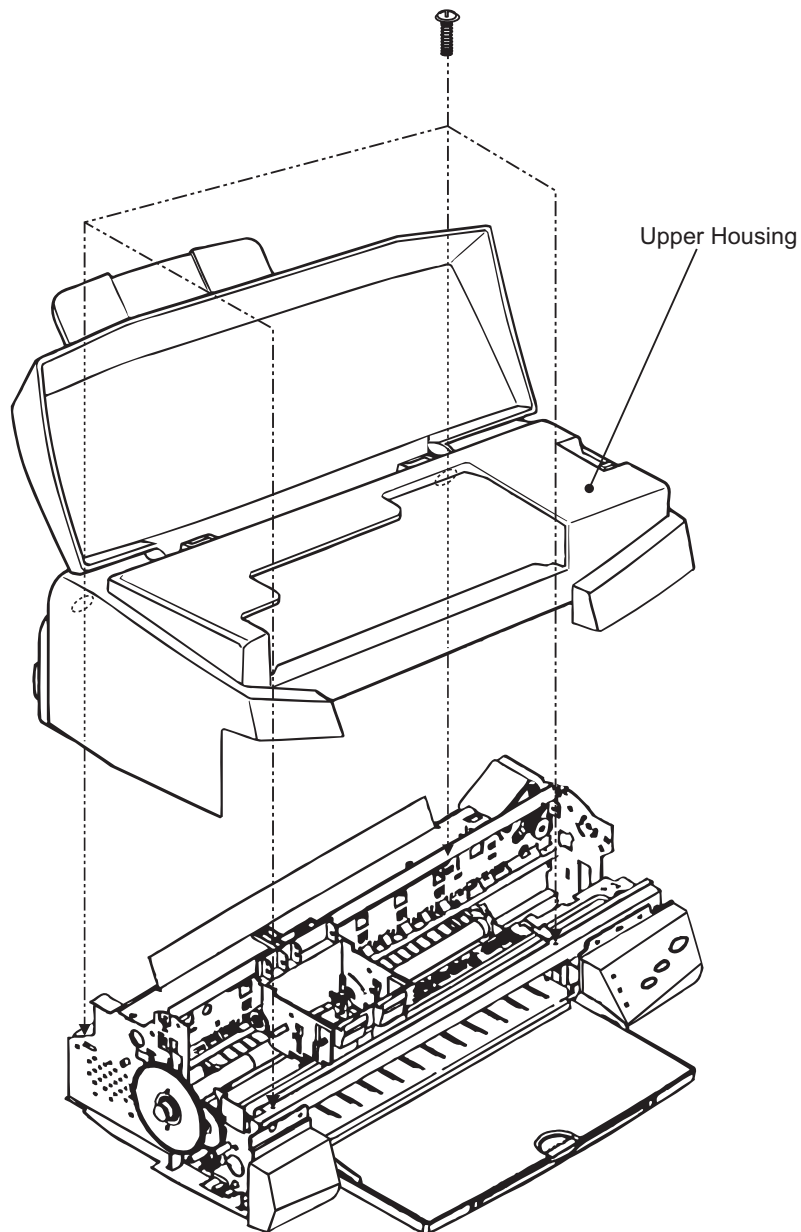

Figure 3-2. Housing Removal

3.2.2 Circuit Boards Removal

The electric circuit boards of the printer (Main control circuit board: C200 MAIN / Power supply circuit board: C206 PSB/PSE) are both installed on single metal chassis and attached to the printer mechanism. Therefore, first detach the metal chassis from the printer mechanism to remove the electric circuit boards.

1. Remove the upper housing (Refer to section 3.2.1)
2. Remove 5 screws (No.1 / three at the back of the printer mechanism and one each at both sides of the printer mechanism)
3. Slightly pull out "SHIELD PLATE, M/B" (metal chassis) from the printer mechanism and take out the cable holders inserted to the edge of "SHIELD PLATE, M/B".
4. Fully separate "SHIELD PLATE, M/B" from the printer mechanism and remove all cables connected to the connectors on the main board; C200 MAIN.
5. If you need further to remove each electric circuit board from "SHIELD PLATE, M/B", remove the screws fixing each board and remove it.

- C200 MAIN BOARD: 10 screws (No.1 = 7 screws, No.6 = 3 screws)
- C206 PSB/PSE BOARD: 4 screws (No.1)

Also disconnect the cable from the connector; CN10 (locking type) on the C200 MAIN, when you remove the C206 PSB/PSE BOARD.

WORK POINT

Unlock the connector CN6/7 on the C200 MAIN by pulling its lock before disconnect the cables, and be sure to lock it when reconnecting the cables.

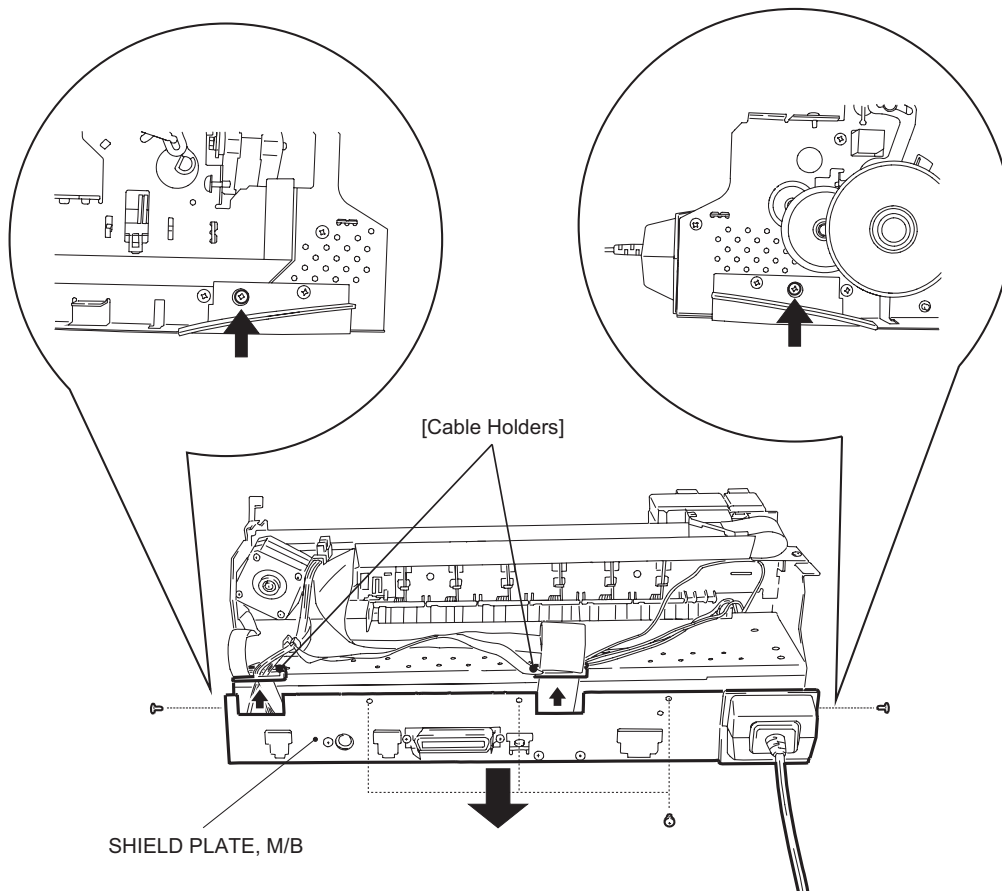

Figure 3-3. SHIELD PLATE M/B Removal

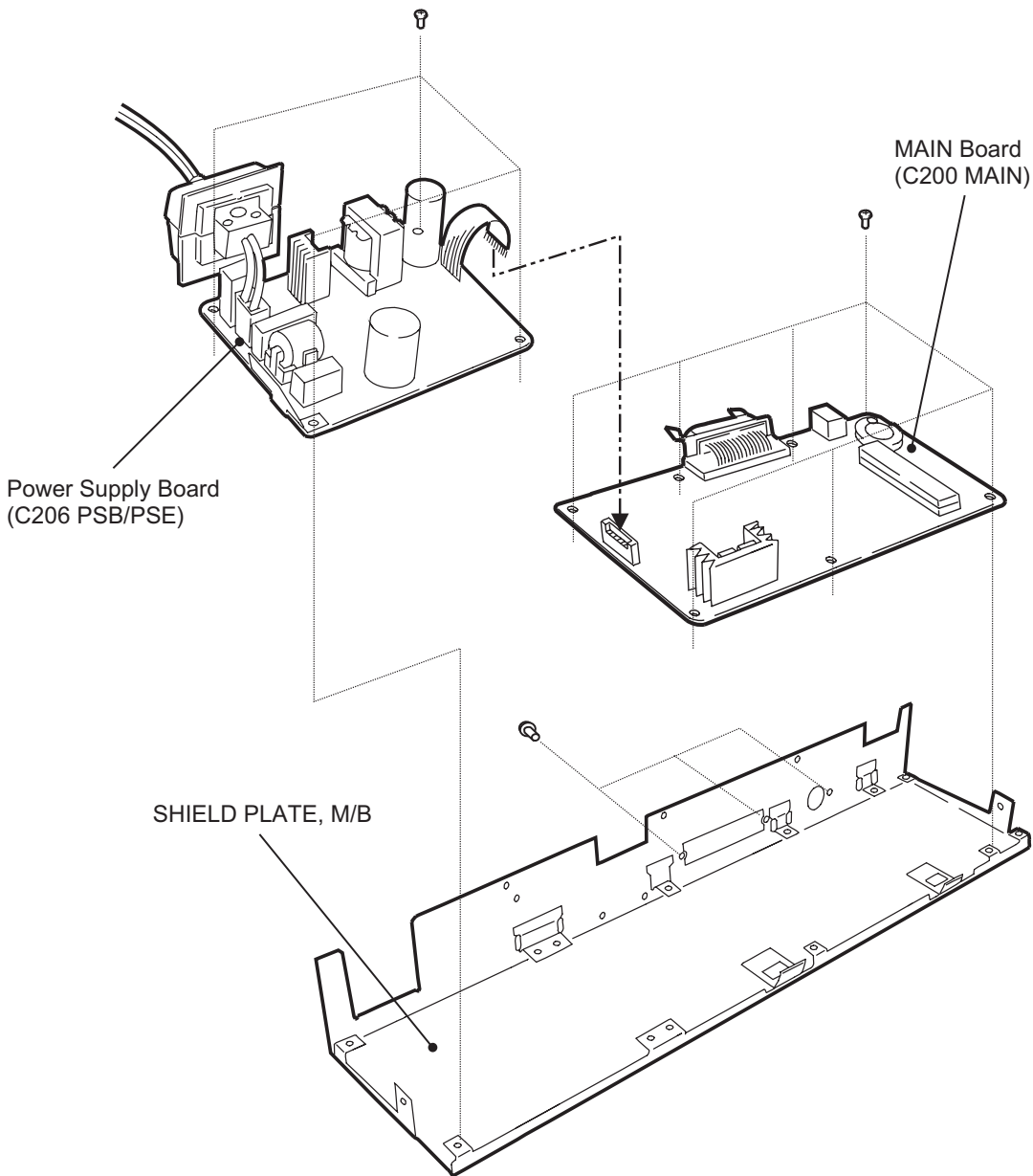

Figure 3-4. Circuit Boards Removal

REQUIRED ADJUSTMENT

Be sure to perform the following adjustments when the C200 MAIN board is replaced:

- 1) VH Voltage value writing (Refer to Chapter 4 / Section 4.2.2.3.)
- 2) Printhead Angle Adjustment (Refer to Chapter 4 / Section 4.2.2.4.)
- 3) Bi-D Alignment Adjustment (Refer to Chapter 4 / Section 4.2.2.5.)

3.2.3 Control Panel Removal

1. Remove the upper housing (Refer to Section 3.2.1)
2. Remove 2 screws (No.1) and remove the control panel assembly from the printer mechanism and disconnect the flat cable from the connector of the panel assembly.

WORK POINT

By removing the control panel assembly, the stacker assembly is also detached from the printer mechanism as it held by the control panel assembly.

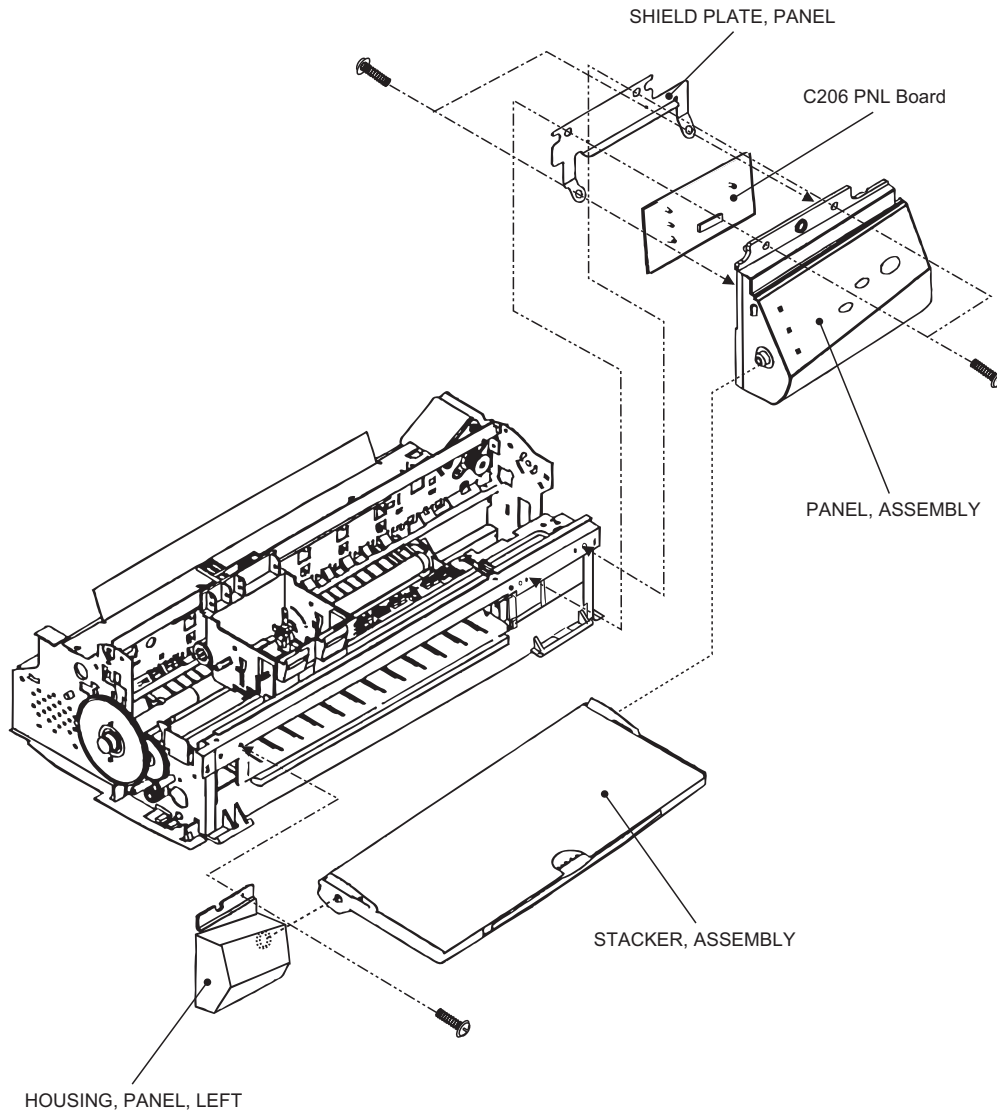

Figure 3-5. Control Panel Removal

3.2.4 Waste Ink Pad Assembly Removal

- 1. Removing the upper housing (Refer to section 3.2.1)
- 2. Removing the control panel assembly (Refer to section 3.2.3)
- 3. Remove 1 screw (No.4) at the right-hand side of the printer mechanism, that fixing "Waste Ink Pad Assembly".
- 4. Remove "SPACER, TRAY" fixing "Waste Ink Pad Assembly" at the left-hand side of the printer mechanism and remove "Waste Ink Pad Assembly" by pulling it downward.

CAUTION

When you replace "Waste Ink Pad Assembly" to new one, be sure to perform the ink counter reset operation. (Refer to Chapter 1 / Section 1.4.2 for details)

WORK POINT

When re-installing "Waste Ink Pad Assembly", be sure that "Stopper, Stacker" that attached to the exit roller shaft is correctly pushed in to back of the projections of "Waste Ink Pad Assembly".

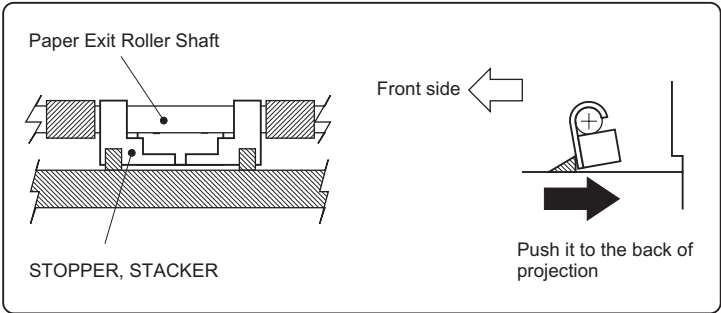
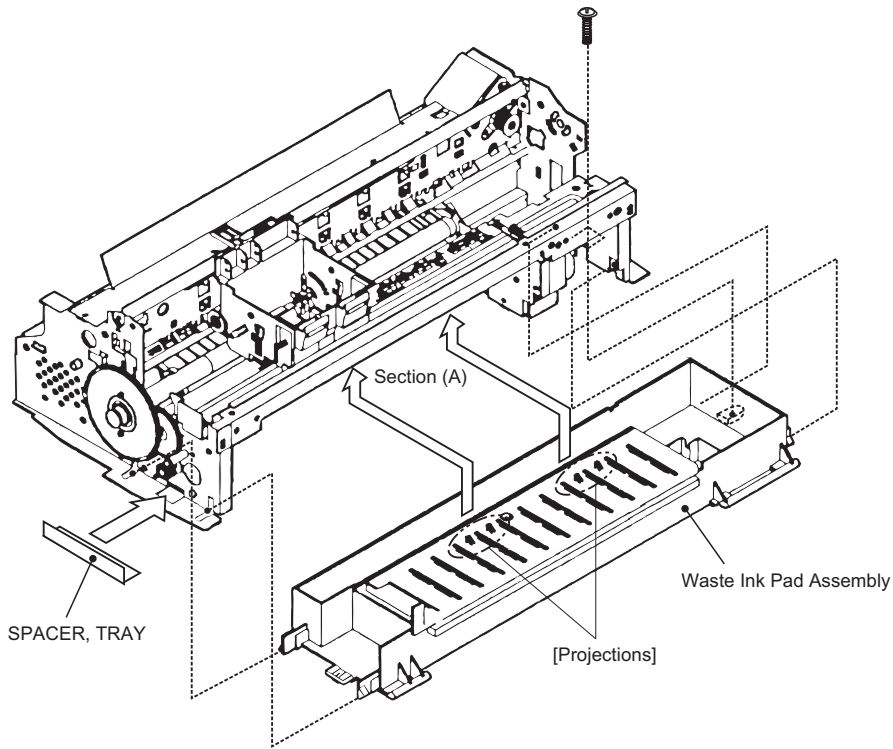

Figure 3-6. Waste Ink Pad Assembly Removal

3.2.5 Disassembling the Printer Mechanism

This section describes the procedures for removing the main components consisting the printer mechanism.

3.2.5.1 Printhead Removal

1. Removing the upper housing. (Refer to section 3.2.1)
2. Rotate "Gear, 67.2" (largest gear at the left-hand side of the printer mechanism) toward the front to disengage the carriage lock mechanism, and move the carriage assembly to the middle of the printer.
3. Remove both black and color ink cartridges.
4. Remove both carriage cover assemblies from the carriage.
5. Remove "Twist Spring, 49" at left-hand side of the carriage and remove 1 screw (No.3) fixing "FASTNER, HEAD". Then, remove "FASTNER, HEAD" from the carriage.
6. Unhook the flat cables from the carriage assembly and take out the printhead unit from the carriage.
7. Disconnect the cables from the connector of the printhead unit.

WORK POINT

- ☑ Notice that the grounding plate is installed in correct position. (there are two fixing pins in the carriage)
- ☑ Be sure that fixing pin of the carriage is correctly located into the cut out of the printhead unit.

CAUTION

- ☑ Once the ink cartridge is removed, it is not re-usable and always install brand-new ink cartridge before returning the printer to the user.
- ☑ When returning the printer to the user, be sure that the ink cartridge is installed and the carriage is at the capping position. (Turn the printer off while the carriage is at the capping position and pack it)

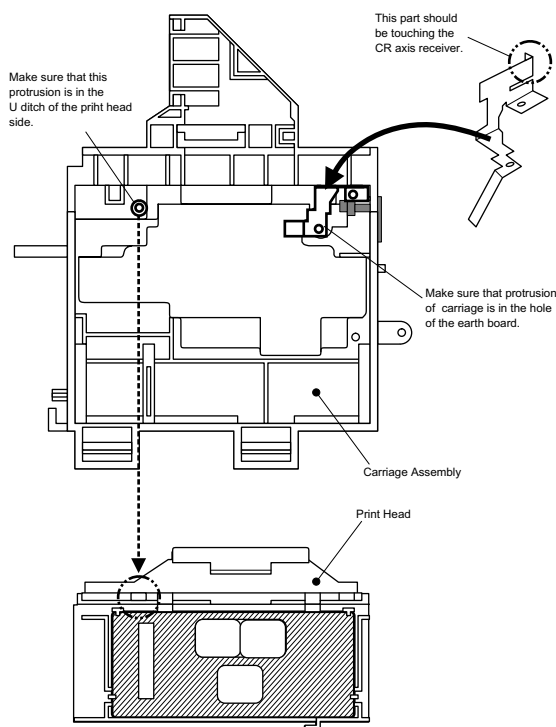

Figure 3-7. Printhead Installation

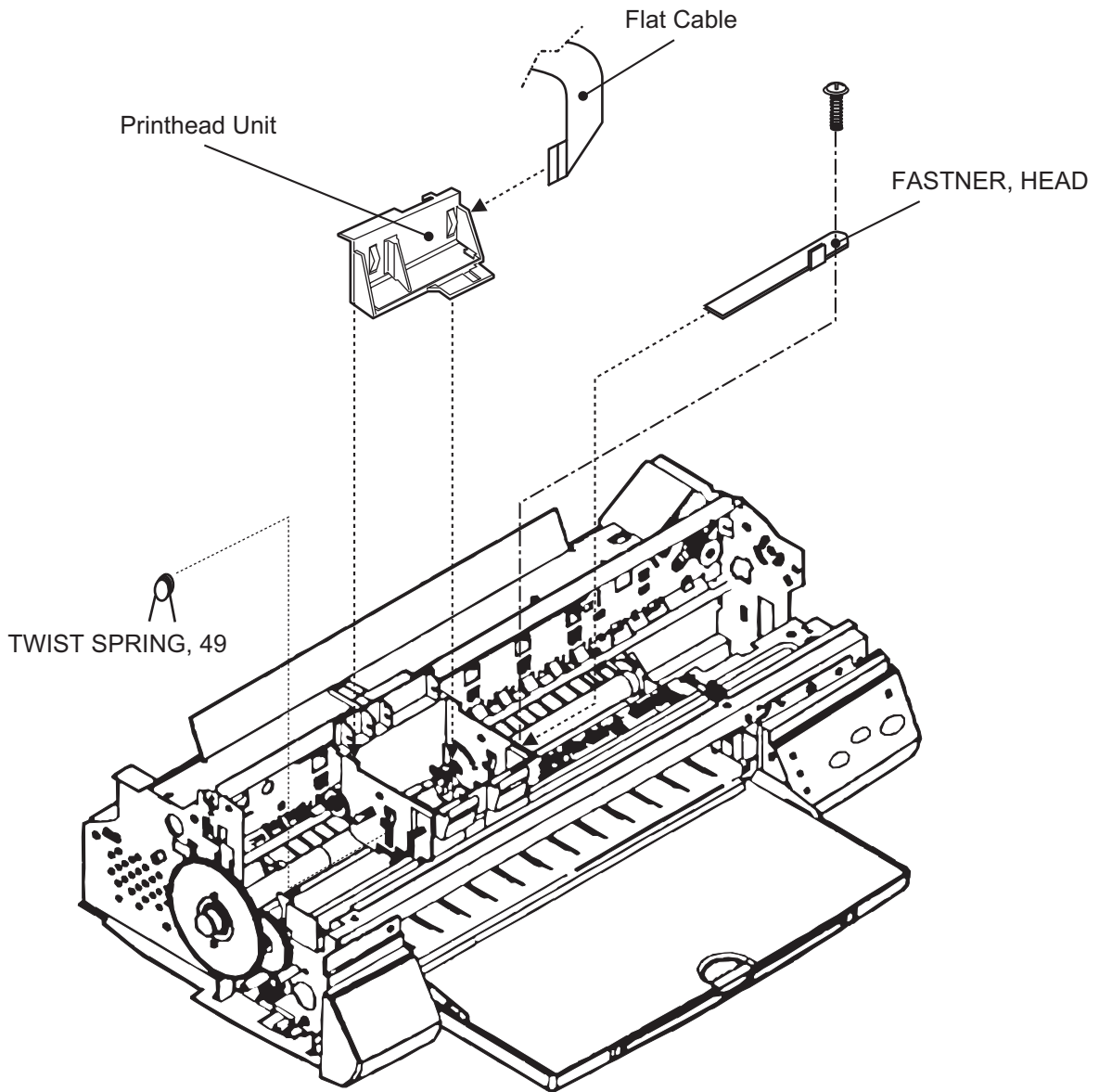

Figure 3-8. Printhead Unit Removal

REQUIRED ADJUSTMENT

When you remove or replace the printhead unit, be sure to perform the following adjustments:

- 1) *Ink Initial Charge Operation (Refer to Chapter 4 / Section 4.2.2.2.)*
- 2) *VH Voltage Writing Operation (Refer to Chapter 4 / Section 4.2.2.3.)*
- 3) *Head Angle adjustment (Refer to Chapter 4 / Section 4.2.2.4.)*

3.2.5.2 Pump Assembly and Cap Assembly Removal

1. Removing the upper housing. (Refer to Section 3.2.1)
2. Removing the control panel assembly. (Refer to section 3.2.3)
3. Removing "Waste Ink Pad Assembly". (Refer to section 3.2.4)
4. Loosen 2 screws (No.1) fixing the exit frame assembly and disengage the frame from the side frames. Then, put the printer mechanism on its back as you see the bottom of the mechanism.
5. At the right-hand of the mechanism, unhook the cap assembly by releasing one hook and take out the cap assembly by lifting up the right end of it. (Note that the cap assembly is still connected to the pump assembly by the ink tube.)
6. Remove 2 screws (No.5) fixing the pump assembly to the frame.
7. Unhook the pump assembly by releasing one hook and slide the pump assembly to the right direction to remove it.

CAUTION

- ☑ Be careful not to damage rubber part of the cap assembly. (Damaging the rubber part causes incomplete capping and the nozzle condition become unstable.)
- ☑ Be careful with the followings when you handle "CLEANER, HEAD":
 - Do not handle it with bare hands and avoid attaching any oil or dust.
 - Make sure that the rubber side of "CLEANER, HEAD" is facing to the right.

WORK POINT

- ☑ Be careful not to popping the components from the pump assembly when you remove it from the mechanism, as there is a spring inside the pump assembly.
- ☑ Be sure that the ink tube from the cap assembly is routed to the correct position and not pinched by the cap assembly and the frame.
- ☑ Verify that "CLEANER, HEAD" moves smoothly by rotating "GEAR, 67.2" after you re-assemble the pump assembly. (Hold the cap assembly to the right while you rotating the gear for check)

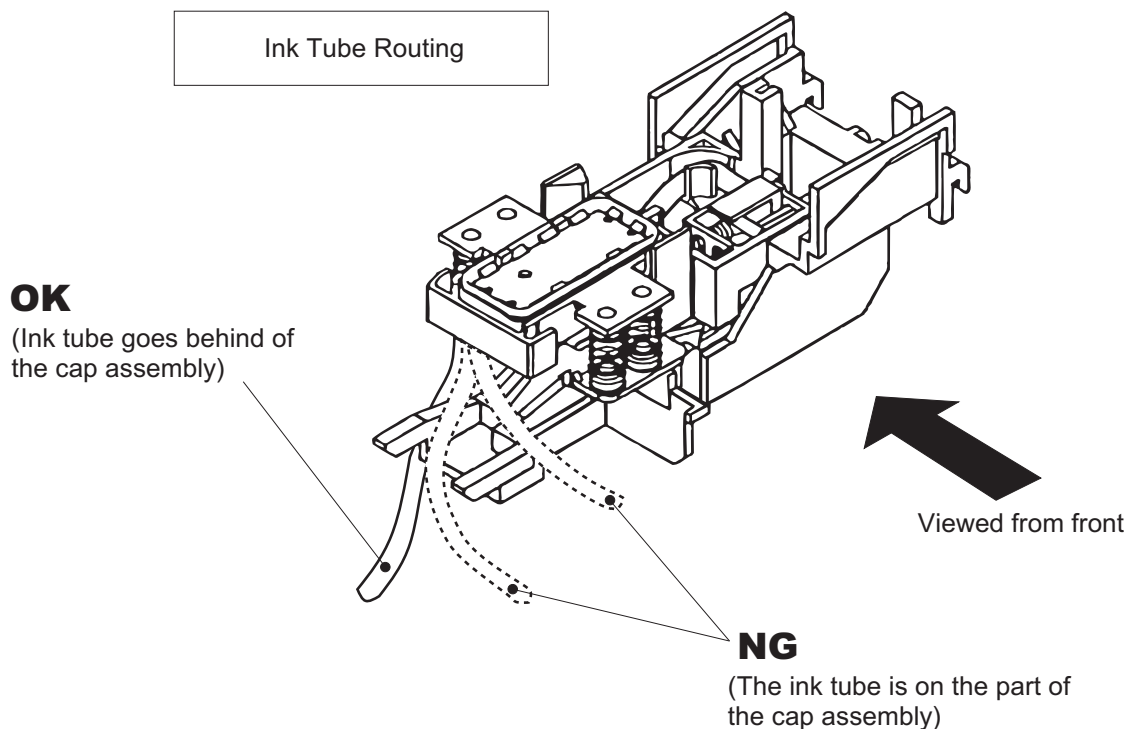

Figure 3-9. Ink Tube Routing

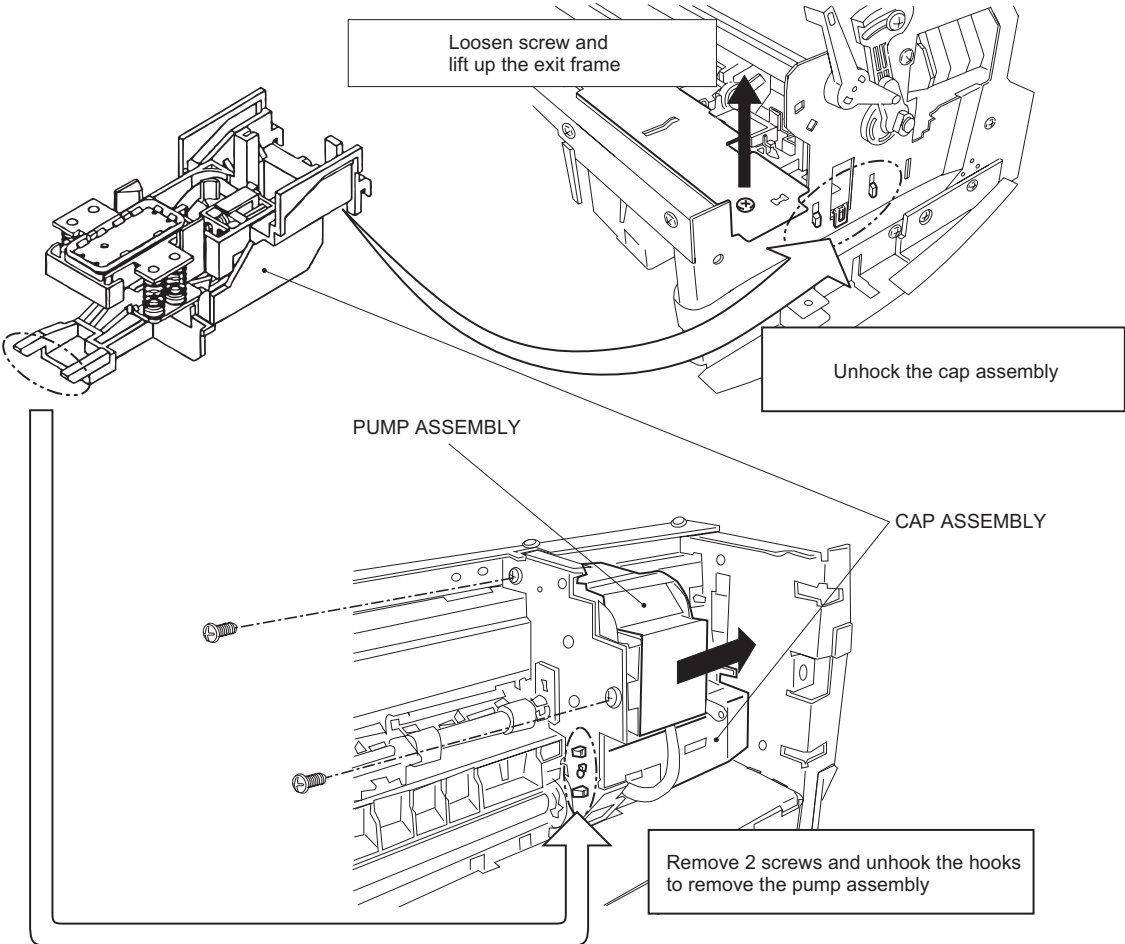

Figure 3-10. Cap Assembly Removal

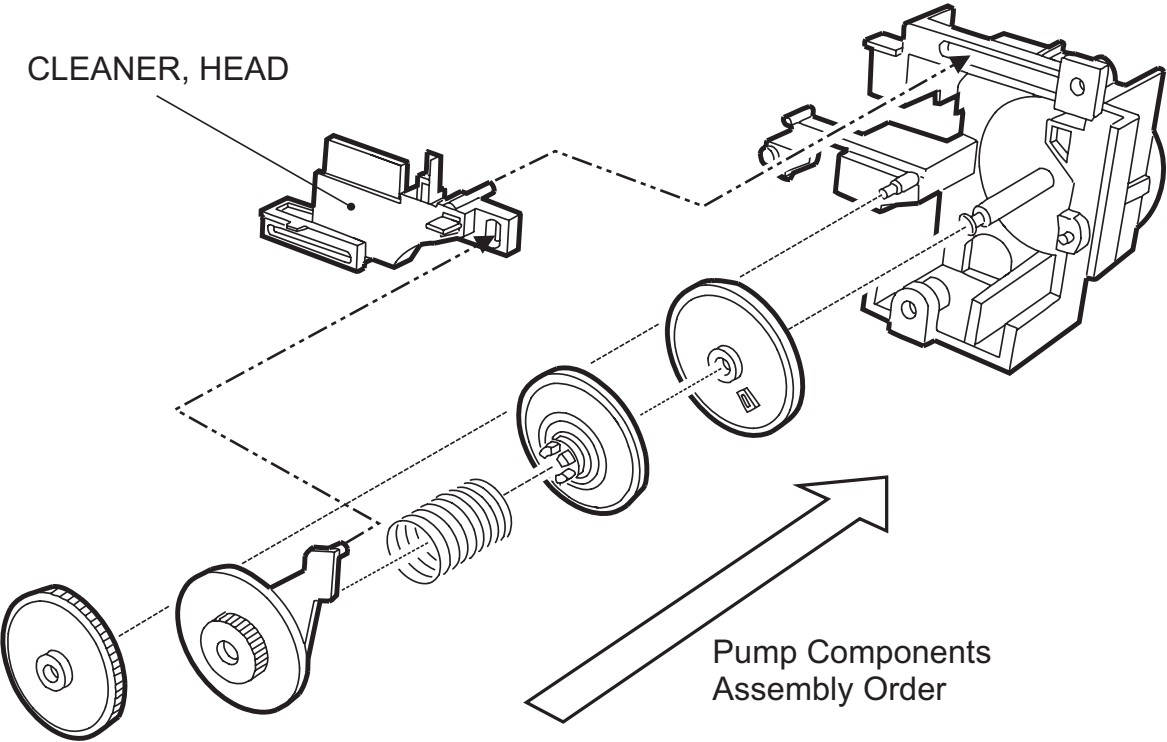

Figure 3-11. Pump Assembly Removal

3.2.5.3 CR Motor Assembly Removal

1. Removing the upper housing. (Refer to section 3.2.1)
2. Rotate "Gear, 67.2" (largest gear at the left-hand side of the printer mechanism) toward the front to disengage the carriage lock mechanism, and move the carriage assembly to the middle of the printer.
3. Push "HOLDER, PULLEY, DRIVEN" inward to loosen the timing belt and detach the timing belt from the drive pulley of CR Motor assembly.
4. Remove 2 screws (No.1) and remove "MOTOR, ASSEMBLY, CR" from the mechanism.

WORK POINT

Be sure that the projections of the motor bracket is inserted to the holes of the frame properly.

REQUIRED ADJUSTMENT

When you replace "MOTOR, ASSEMBLY, CR", be sure to perform the following adjustment:

- 1) *Bi-D Alignment Adjustment (Refer to Chapter 4 / Section 4.2.2.5.)*

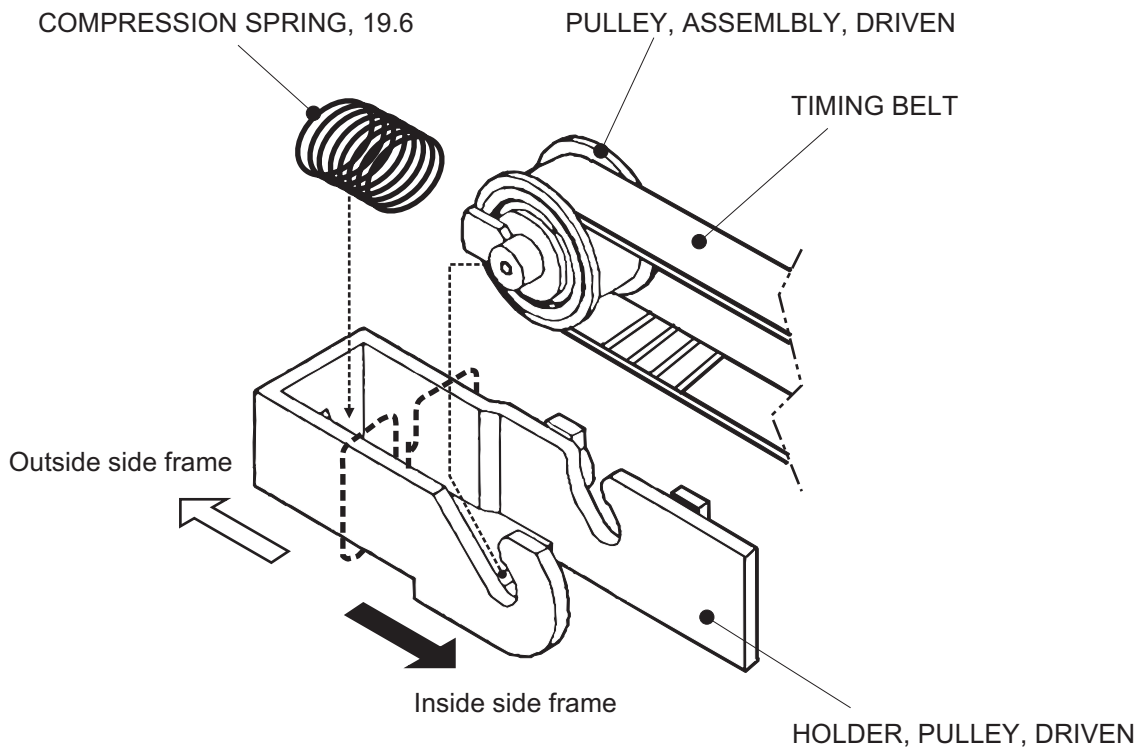
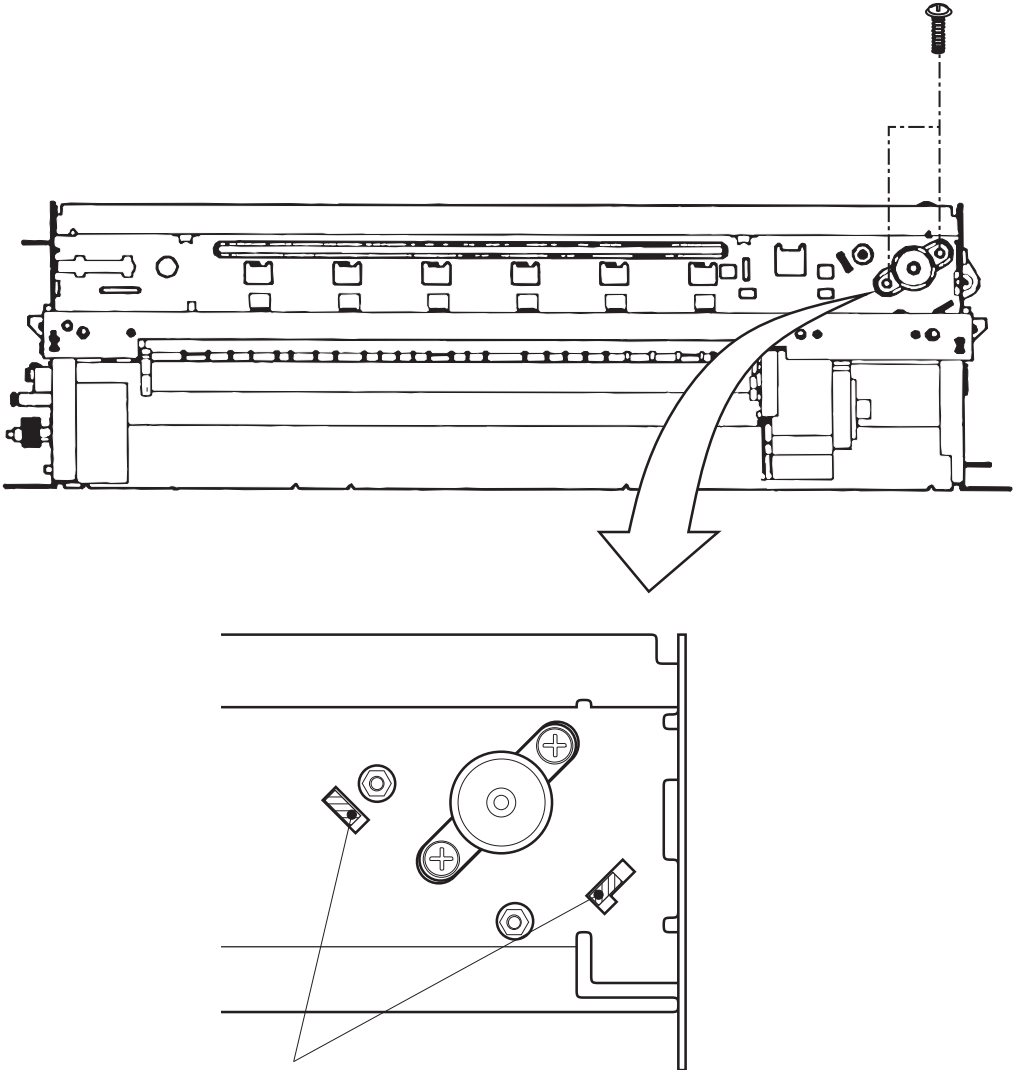

Figure 3-12. Driven Pulley Removal



The projections of motor assembly must locate inside the holes

Figure 3-13. CR Motor Removal

3.2.5.4 PF Motor Assembly Removal

1. Removing the upper housing. (Refer to section 3.2.1)
2. Removing "Waste Ink Pad Assembly". (Refer to section 3.2.4)
3. By referring the figure below, remove the specified gears from the mechanism:
 - "GEAR, 67.2"
 - "COMBINATION GEAR, 8, 14.4"
 - "COMBINATION GEAR, 8.8, 21.6"
 - "GEAR, 36"
4. Remove 2 hexagonal lock nut and remove "MOTOR, ASSEMBLY, PF".

WORK POINT

- ✓ When removing the PF Motor, first, slightly pulling out the PF Motor from the frame and slide the motor shaft to a larger cut out of the frame and remove it.
- ✓ Be careful with the routing direction of the cable from the PF motor.

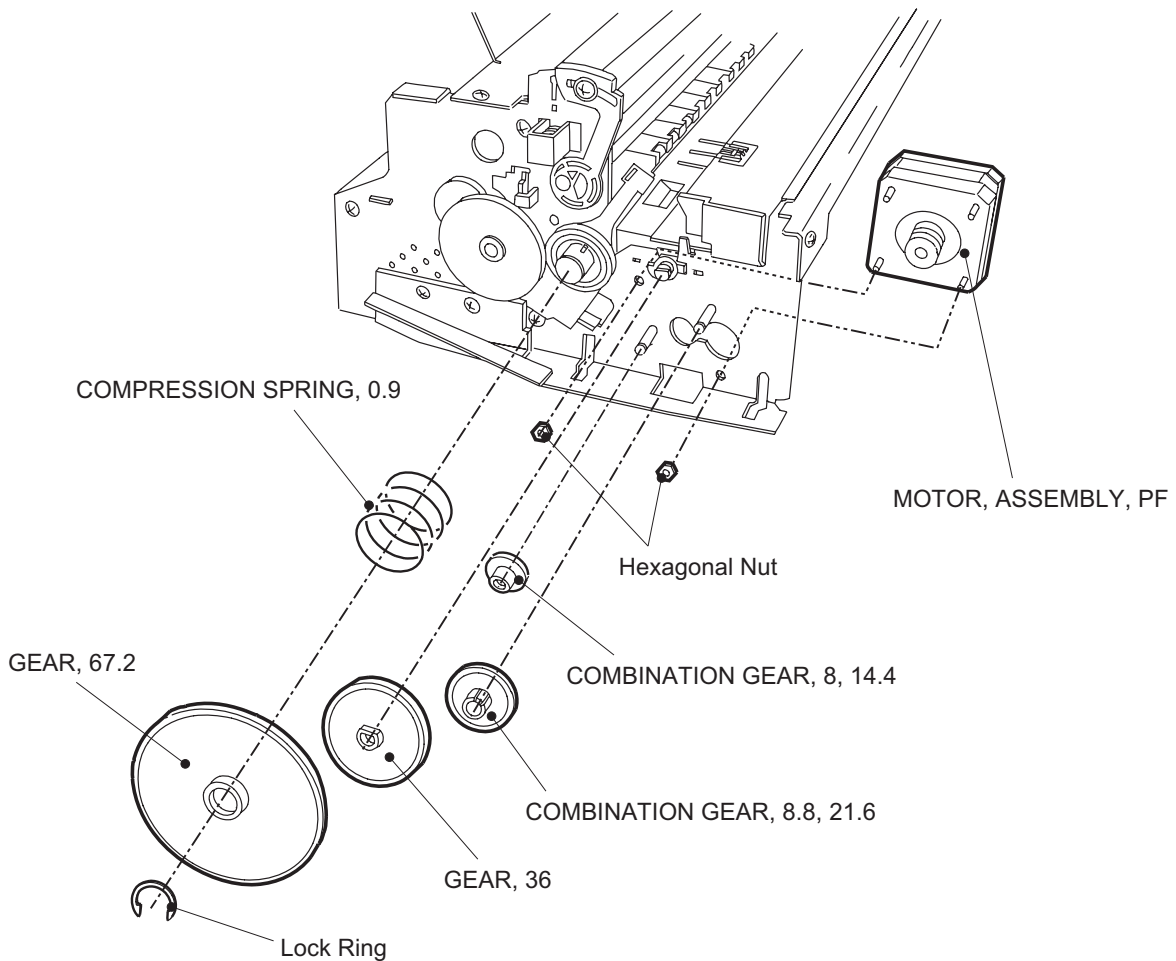

Figure 3-14. PF Motor Removal

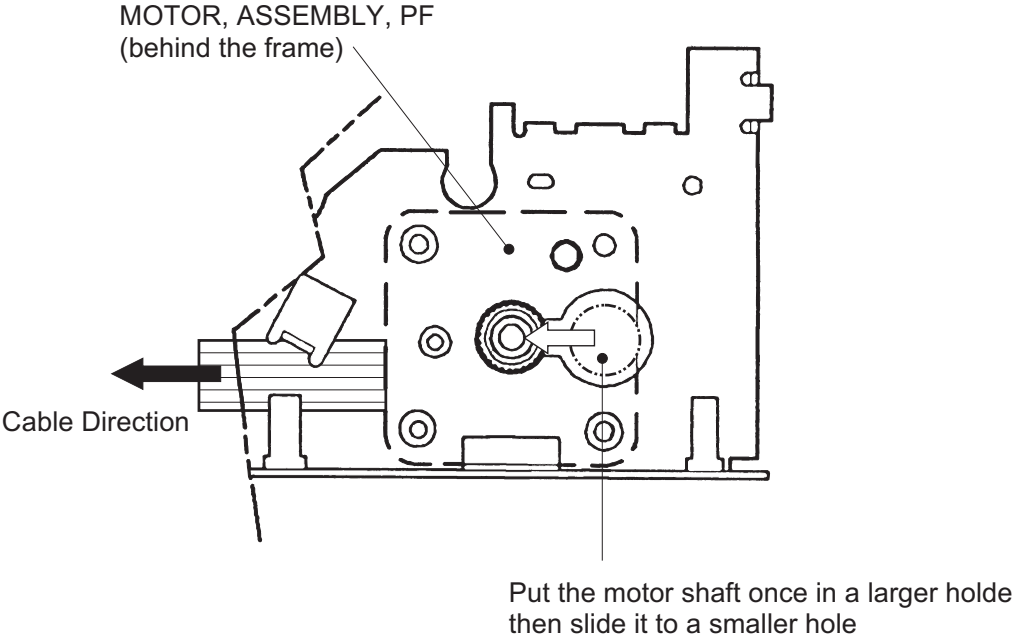

Figure 3-15. PF Motor and Frame

3.2.5.5 ASF Assembly Removal

1. Removing the upper housing. (Refer to section 3.2.1)
2. Remove the locking pin from center of "GEAR, 34" and remove "GEAR, 34" from the shaft.
3. Unhook the cables from the cable hook of the ASF and the printer mechanism.
4. Remove 2 screws (Refer to the figures) fixing the ASF and remove the ASF from the mechanism by detaching the projection of ASF (at left) from the hole of the mechanism.

WORK POINT

- ☑ *Make sure that the ASF is firmly attached to the mechanism.*
- ☑ *Use proper type of screw at specified position (viewed from the back of the mechanism):*
 - Right: "SHAFT, FIXING, CR"*
 - Left: Screw - No.7 (CBS with washer)*

CAUTION

When re-installing the ASF, be sure that no cables (except the flat cable to the printhead) are pinched between the ASF and the frame.

Especially, if the cables from CR/PF Motor is pinched, there is a danger of short-circuit with the frame and possibly causes hazardous problem like over-heating, burning of components.

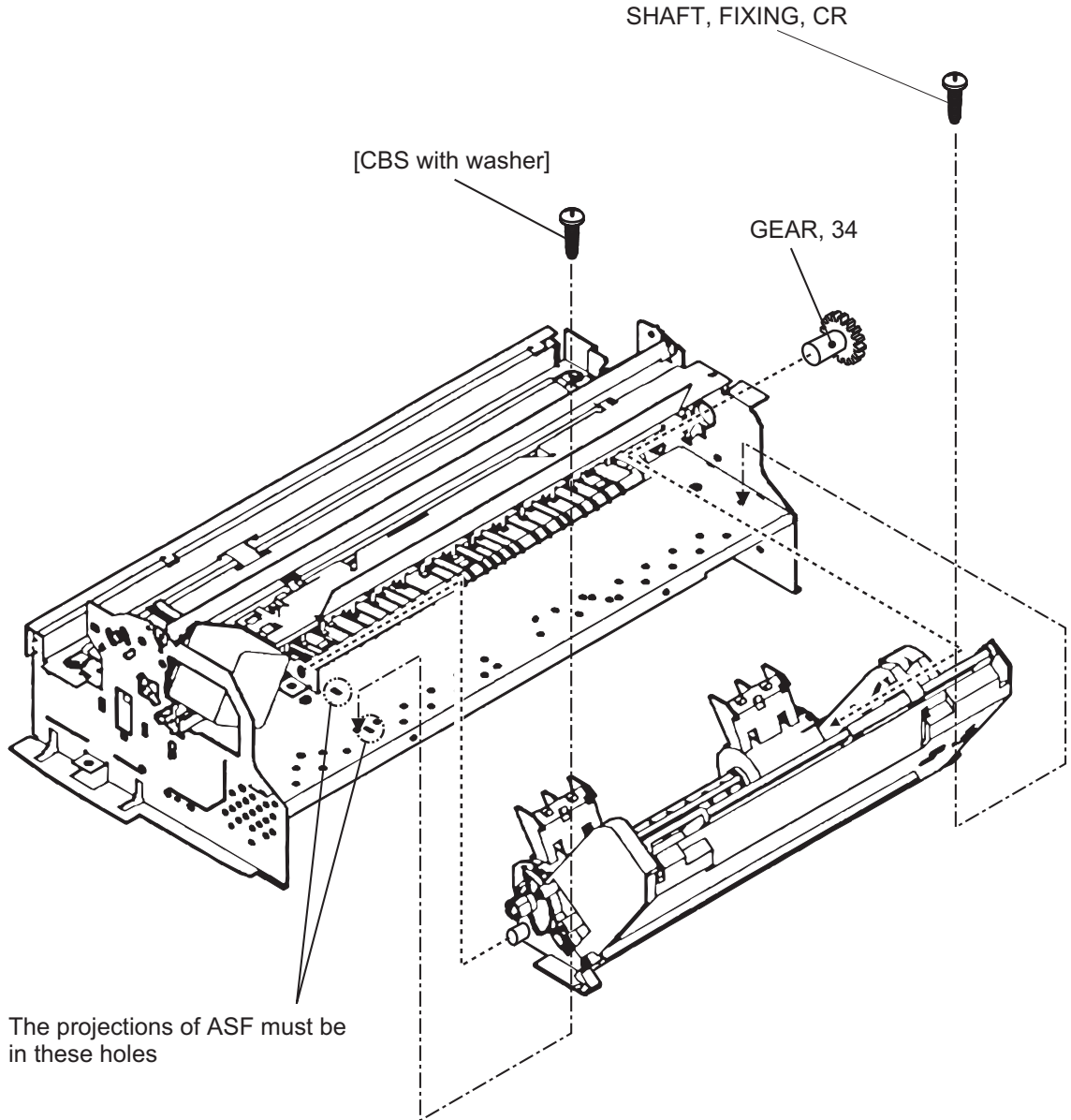

Figure 3-16. ASF Assembly Removal

3.2.5.5.1 ASF Disassembly

1. Removing the ASF. (Refer to section 3.2.5.5)
2. Remove "TWIST SPRING, 41.2" by unhooking one end from the ASF frame and remove "LEVER, BRAKE".
3. Remove "BUSH, FIXING, SHAFT" from the right end of "SHAFT, ROLLER, LD" and remove "LEVER, HOPPER, RELEASE".
4. Move the left paper pack-up assembly to the middle of the ASF and remove "BUSH" from the shaft.
5. Push out "SHAFT, ROLLER, LD" to the left and remove "BUSH, FIXING, SHAFT, LEFT" from the left-end of the shaft.
6. Unhook the top of "HOPPER, ASSEMBLY" from the both sides of "FRAME, ASF".
7. Push out "SHAFT, ROLLER, LD" to the right while pulling up "PICKUP, ROLLER ASSEMBLY, RIGHT" slightly. Then, detach the left end of "SHAFT, ROLLER, LD" from "FRAME, ASF".
8. Holds "HOPPER, ASSEMBLY" and remove the right cam part of "HOPPER, ASSEMBLY" through the hole at the right side of "FRAME, ASF".

To this point, the ASF assembly is disassembled and both left and right "PICKUP, ROLLER ASSEMBLY" and "HOPPER, ASSEMBLY" are separated.

WORK POINT

- ☑ When removing "HOPPER, ASSEMBLY", be careful that the grease that applied to the cam part of it, is not attaching to other part of the ASF. If so, wipe it off completely.
- ☑ Make sure that bushes at the both ends of the shaft are firmly attached.

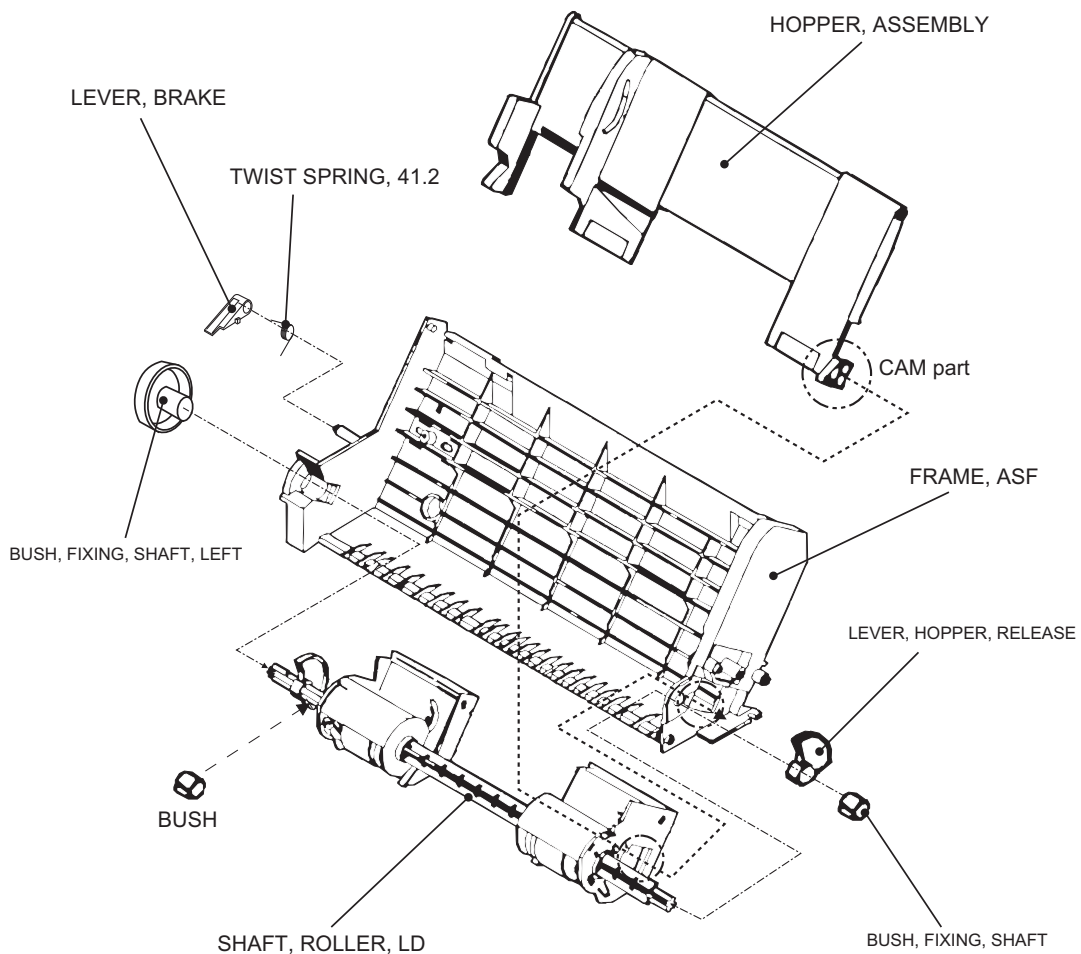

Figure 3-17. ASF Disassembly

3.2.5.5.2 Pick-Up Roller Assembly Removal

1. Disassemble the ASF and separate "PICKUP, ROLLER ASSEMBLY" and "HOPPER, ASSEMBLY". (Refer to section 3.2.5.5.1)
2. Remove "COMPRESSION SPRING, 1.66" from the back of "HOPPER, ASSEMBLY".
3. Pull out the right cam part of "HOPPER, ASSEMBLY" though the hole of right frame of "PICKUP, ROLLER ASSEMBLY, RIGHT".

<To this point, "HOPPER, ASSEMBLY" and "PICKUP, ROLLER ASSEMBLY" is separated>

4. Unhook "ROLLER ASSEMBLY, LD" from the assembly frame and remove "COVER, ROLLER, LD" by unhooking it from the assembly frame. Then, remove "ROLLER ASSEMBLY, LD".

WORK POINT

- ☑ When you re-assemble, be sure that "ROLLER ASSEMBLY, LD" is hooked to assembly frame firmly.
- ☑ Before re-assemble the unit, make sure that "COMPRESSION SPRING, 1.66" is set on the assembly frame and hooked to the hooks as shown in the figure. This helps you easier assembly. After assemble the unit, do not forget to unhook the springs by rotating the spring from the holes located at the back of the ASF assembly.

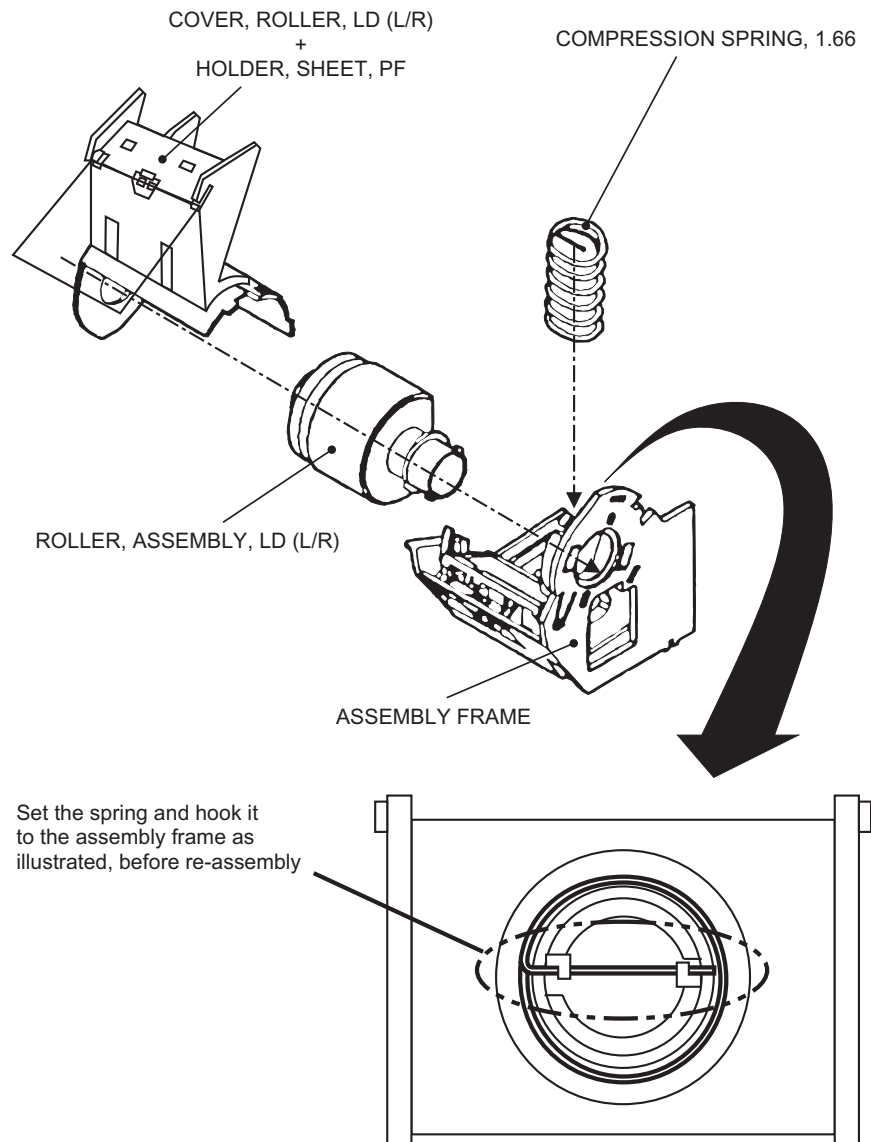

Figure 3-18. Pick-Up Roller Removal

3.2.5.6 Carriage Assembly Removal

1. Removing the upper housing. (Refer to section 3.2.1)
2. Push "HOLDER, PULLEY, DRIVEN" inward to loosen the timing belt and detach the timing belt from the drive pulley of CR Motor assembly.
3. Take out "COMPRESSION SPRING, 19.6" from "HOLDER, PULLEY, DRIVEN".
4. Remove "PULLEY, ASSEMBLY, DRIVEN" and the timing belt together from "HOLDER, PULLEY, DRIVEN" and remove "HOLDER, PULLEY, DRIVEN" from the mechanism.
5. Unhook "LEVER, PG" and remove it.
6. Unhook "LEVER, PG, SUB" and remove "LEVER, PG, SUB" and a spring washer from the end of "SHAFT, CR, GUIDE".
7. Remove 1 screw (No.7) and rotating "BUSH, PARALLEL ADJUST, RIGHT" to match it with the cut out of the frame. Then, take out "BUSH, PARALLEL, ADJUST, RIGHT".
8. Remove "CARRIAGE, ASSEMBLY" together with "SHAFT, CR, GUIDE".

WORK POINT

- ☑ It is good idea to marking the current position of "BUSH, PARALLEL ADJUST, RIGHT" before removal. This enables you to omit the paper gap adjustment after the assembly.
- ☑ Be careful with the direction of spring washer at the assembly. (A convex side must facing the bush)

REQUIRED ADJUSTMENT

When you remove or replace the carriage assembly, be sure to perform the following adjustments:

- 1) Paper Gap Adjustment (Refer to Chapter 4 / Section 4.2.1.)
- 2) Head Angle Adjustment (Refer to Chapter 4 / Section 4.2.2.4.)
- 3) Bi-D Alignment Adjustment (Refer to Chapter 4 / Section 4.2.2.5.)

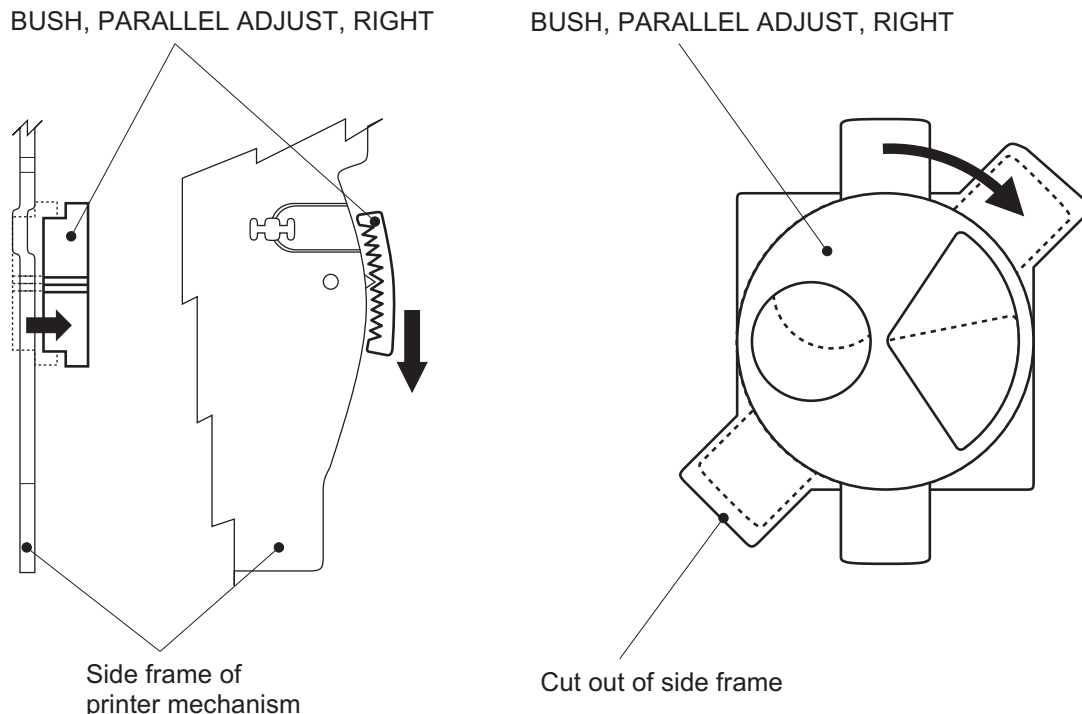

Figure 3-19. BUSH PARALLEL ADJUST Removal

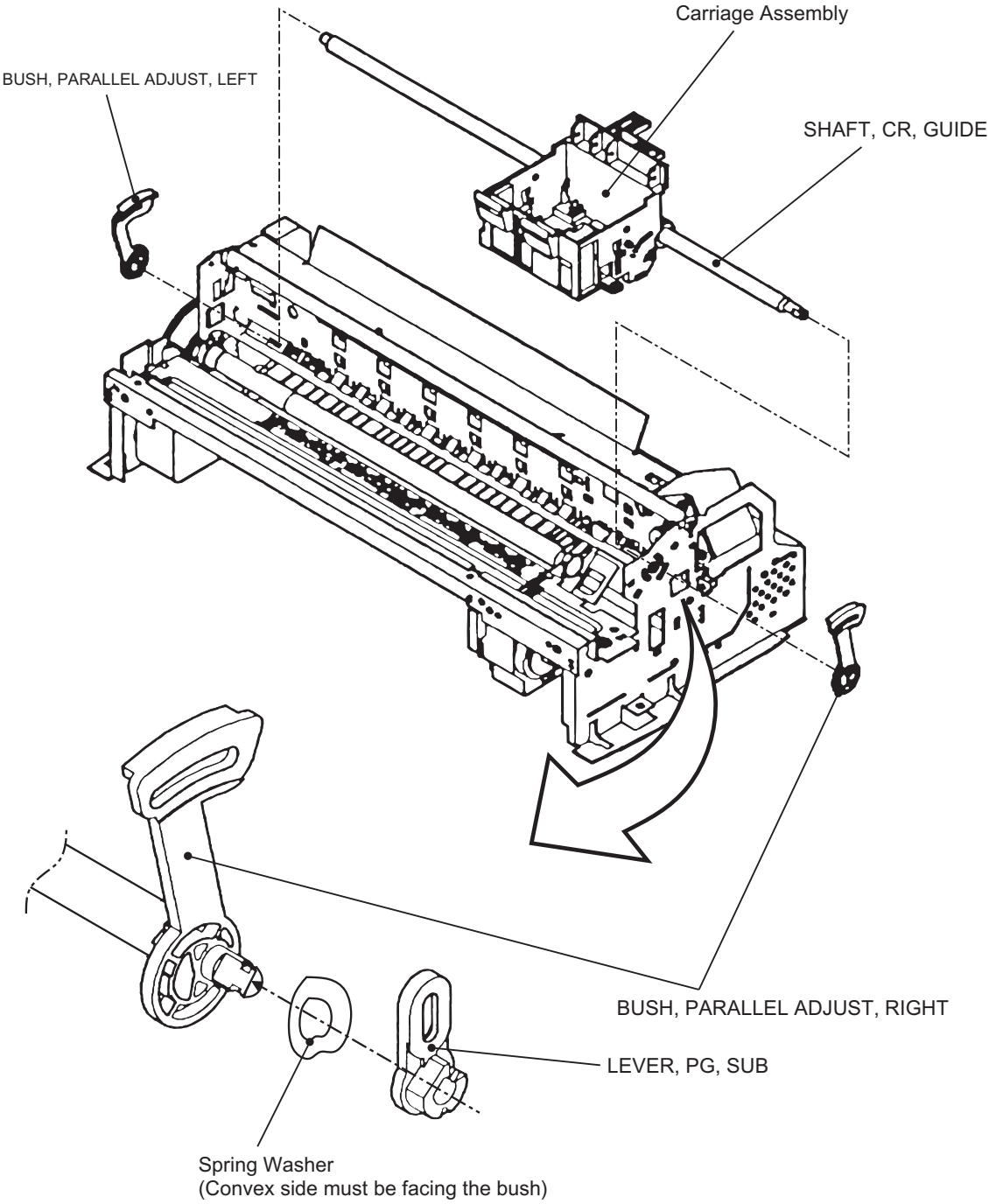

Figure 3-20. Carriage Assembly Removal

3.2.5.7 PF Roller Assembly Removal

1. Removing the upper housing. (Refer to section 3.2.1)
2. Removing the carriage assembly (Refer to section 3.2.5.6)
3. Remove 2 screws (No.1) at the top of mechanism and remove "GUIDE PLATE, CABLE".
4. From the back of the mechanism, unhook the springs from the frame and remove "PAPER GUIDE, ASSEMBLY, UPPER" (total 6 pieces).
5. Unhook "PAPER GUIDE, FRONT;B" and remove it.
6. Unhook the both shaft holders of "ROLLER, ASSEMBLY, PAPER EXIT" and remove it.
7. Unhook the left shaft holder of "ROLLER, ASSEMBLY, PF" and rotate it as to match with the cut out of the frame.
8. Slide "ROLLER, ASSEMBLY, PF" to the left and pulling it out.

WORK POINT

- ☑ When reinstalling "PAPER GUIDE, ASSEMBLY, UPPER" at right-most position (viewed from the front), be careful with the detection lever of the PE sensor.
- ☑ Be careful not to damage the hook of "PAPER GUIDE, FRONT;B" during disassembly and assembly.
- ☑ Be careful not to damage the black coated part of "ROLLER, ASSEMBLY, PF" during disassembly and assembly.
- ☑ Be careful not to damage the gears.

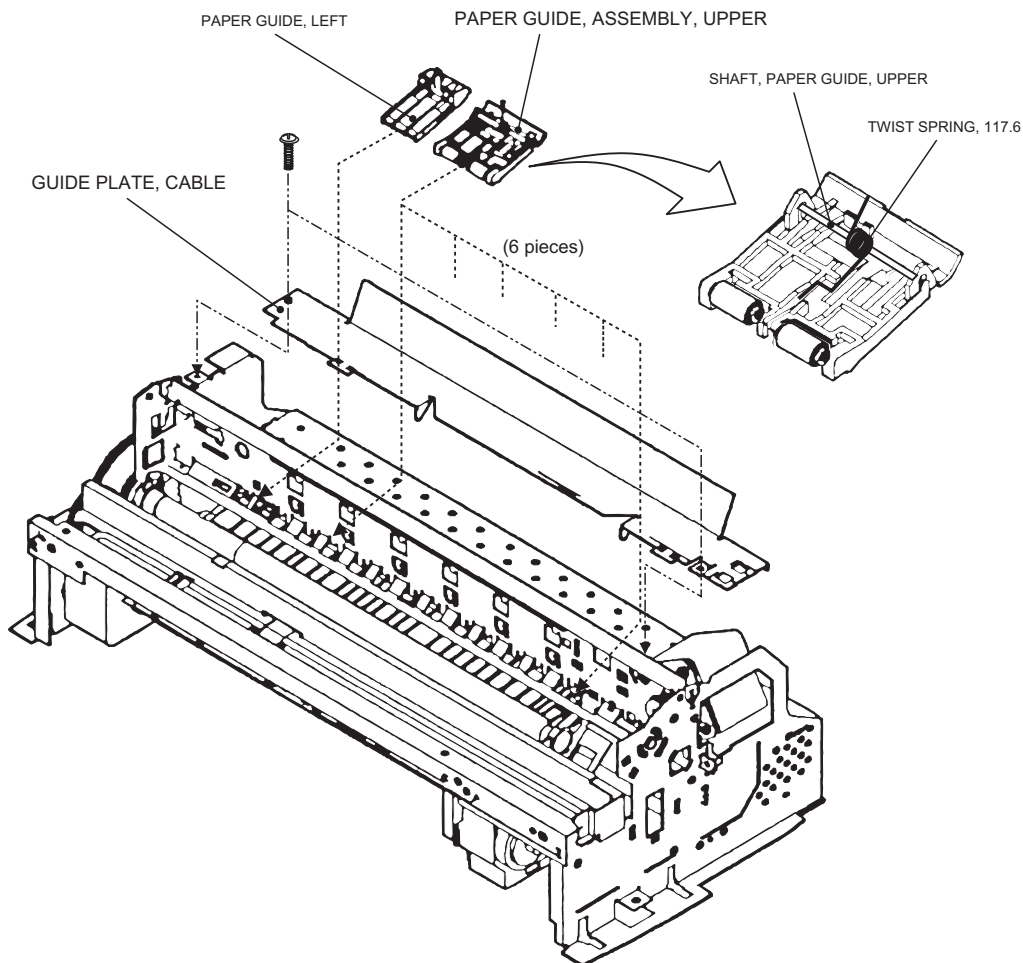

Figure 3-21. PAPER GUIDE ASSEMBLY Removal

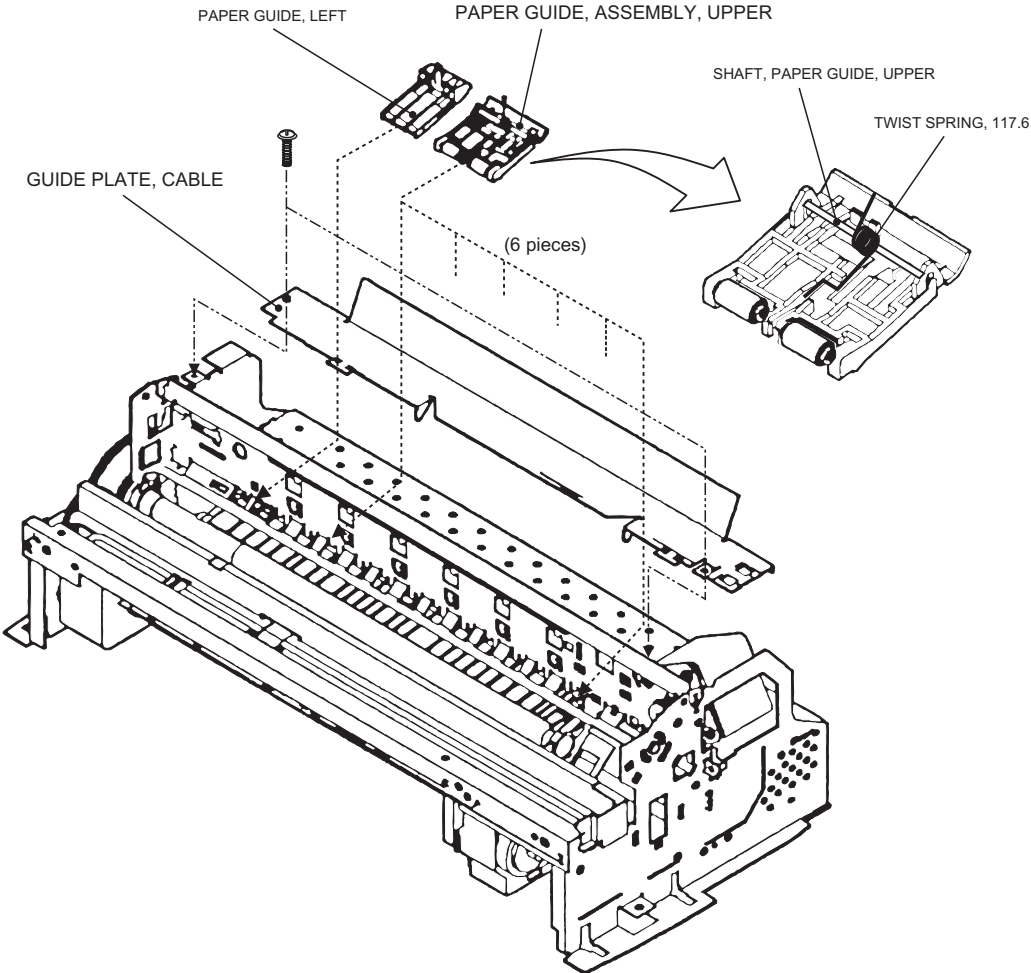

Figure 3-22. ROLLER, ASSEMBLY, PAPER EXIT Removal

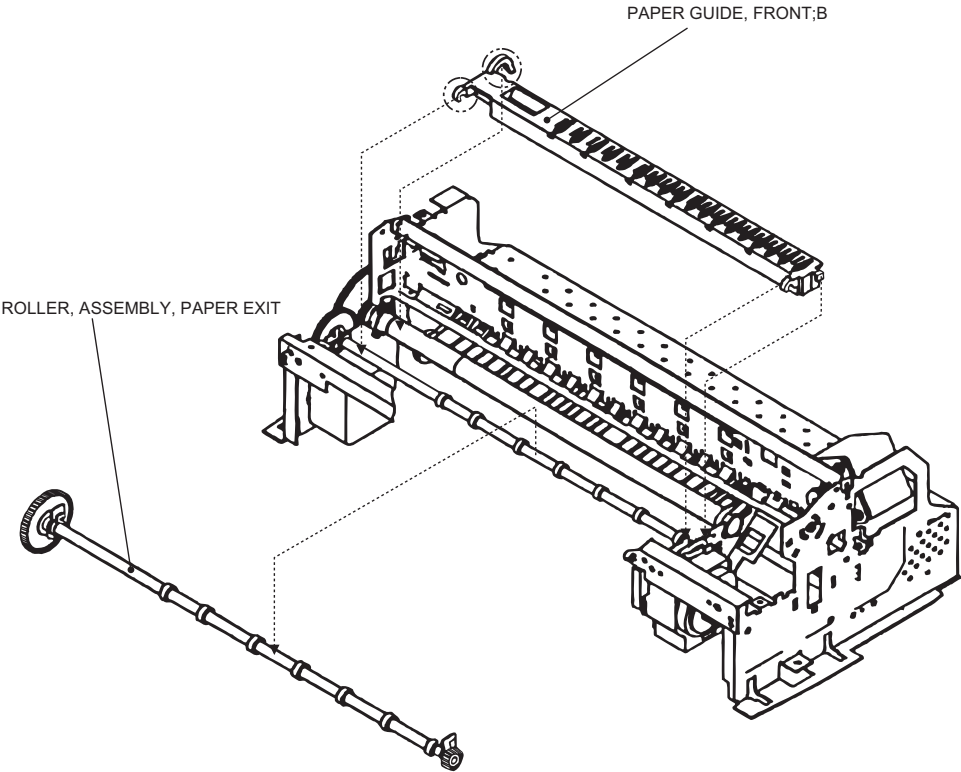

Figure 3-23. ROLLER, ASSEMBLY, PF Removal

3.2.5.8 PE Sensor Assembly Removal

1. Removing the upper housing. (Refer to section 3.2.1)
2. From the front side of the mechanism, unhook two hooks fixing "SENSOR, ASSEMBLY, PE" to the
3. mechanism. Then, slide it to upward to remove it. After removal, disassemble the assembly if necessary.

WORK POINT

When re-install the assembly, be sure that the sensor lever is correctly inserted into a hole of "PAPER GUIDE, ASSEMBLY", UPPER".

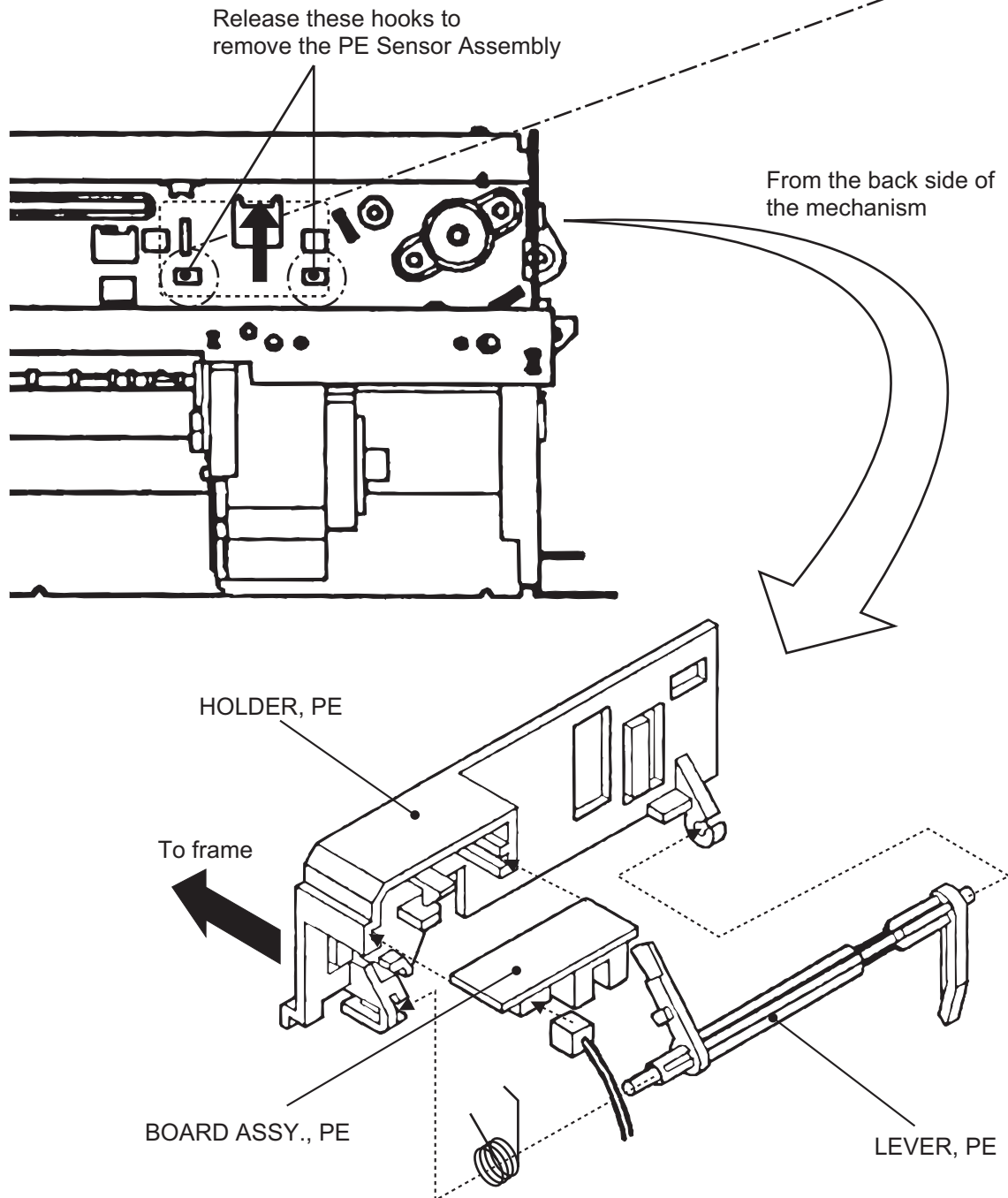

Figure 3-24. PE Sensor Assembly Removal

3.2.5.9 HP Sensor Assembly Removal

- 1. Removing the upper housing. (Refer to section 3.2.1)
- 2. Detach the cable from the sensor and remove it by unhook it from the frame.

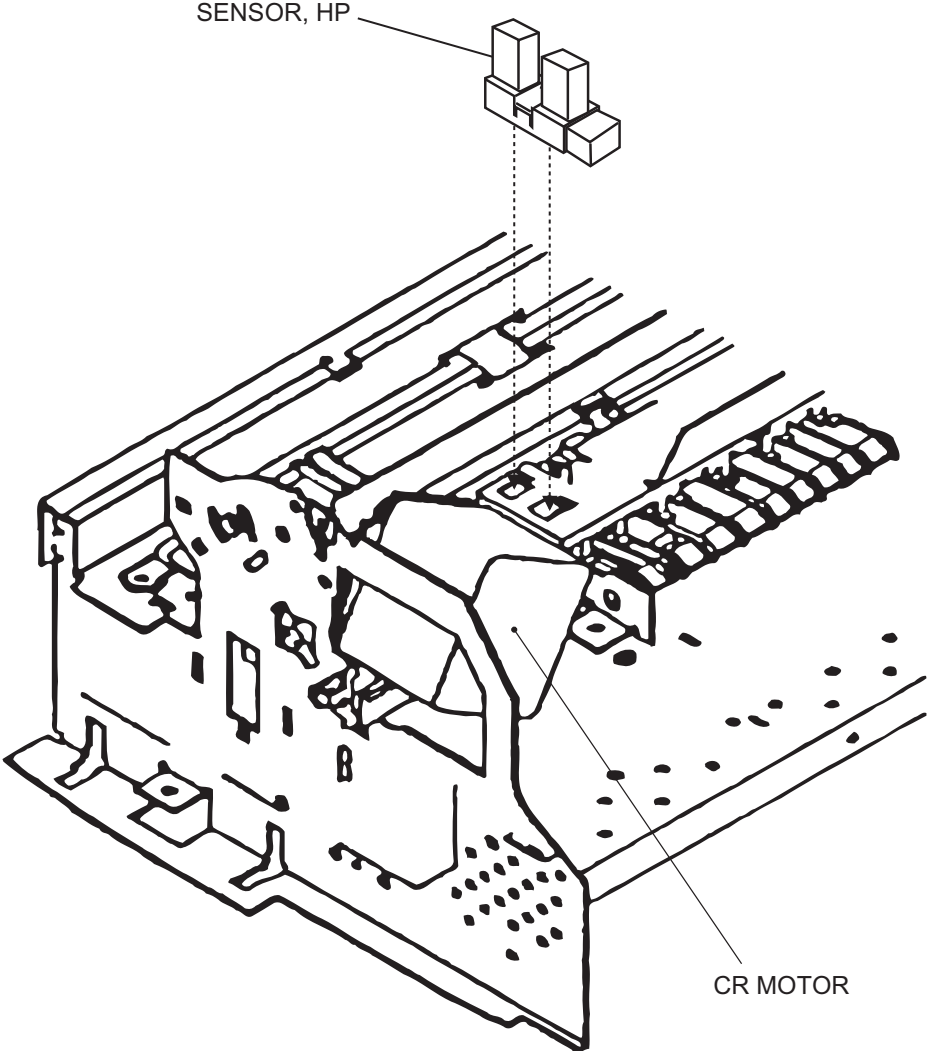

Figure 3-25. HP Sensor Removal

Chapter 4 Adjustment

4.1. OVERVIEW	4-1
4.1.1. Required Adjustments	4-1
4.1.2. Tools Required for Adjustment	4-1
4.2. Adjustments.....	4-2
4.2.1. Paper Gap Adjustment.....	4-2
4.2.2. Adjustment using Adjustment Program	4-4
4.2.2.1. Overview of Adjustment Program	4-4
4.2.2.2. Ink Charge Operation	4-5
4.2.2.3. VH Setting	4-7
4.2.2.4. Head Angular Adjustment.....	4-9
4.2.2.5. Bi-D Alignment Adjustment.....	4-11

4.1 OVERVIEW

This section describes the procedure for adjustments required when the printer is disassembled and assembled for repair.

4.1.1 Required Adjustments

Table 4-1 lists all the adjustments required with this printer. If any service listed in this table is carried out, all adjustments corresponding to that service should be performed to ensure proper operation of the printer.

Table 4-1. Required Adjustments

<i>Performance Order</i>	1	2	3	4	5
Service Performed	Paper-Gap Adjustment	Ink Charge	VH Setting	Head Angular Adjustment	Bi-D Adjustment
Replacing the printer mechanism	NA	○	○	NA	○
Replacing the C209 MAIN board	NA	○	○	○	○
Replacing the printhead unit	NA	○	○	○	NA
Replacing the CR Motor	NA	NA	NA	NA	○
Replacing or disassembling the carriage assembly	○	NA	NA	○	○
Replacing or disassembling the PF Roller assembly	○	NA	NA	NA	NA

Note) "○": Required adjustment

"NA": Not applicable

4.1.2 Tools Required for Adjustment

Table 4-2 lists all the tools required to make the specified adjustments.

Table 4-2. Required Tools

No.	Name	Adjustment	Notes
1	Thickness Gauge	Paper-Gap Adjustment	<ul style="list-style-type: none"> ● Thickness: 1.04mm ● EPSON Code: B776702201
2	Adjustment Program	<ul style="list-style-type: none"> ● Ink Charge ● VH Setting ● Head Angular ● Bi-D Alignment 	<ul style="list-style-type: none"> ● Program Name: J90C00E



Do not use rusty or deformed thickness gauge for adjustment.

Wipe off any dirt or dust from the thickness gauge before use.

4.2 Adjustments

This section describes the detail procedure of each adjustment.

4.2.1 Paper Gap Adjustment

The paper gap is a distance between nozzle surface of the printhead unit and a paper surface and is adjusted to specified gap at the assembly. Therefore, if the carriage assembly is removed from the printer mechanism for any reason, this adjustment should be made to fix the gap.



- ☑ Do not scratch the surface of "PAPER GUIDE, FRONT;B" and "ROLLER, ASSEMBLY, PF".
- ☑ Be careful not to damage or make dirty the nozzle surface of the printhead unit.

[Paper gap - Right-hand side Adjustment]

1. Attach both "BUSH, PARALLEL ADJUST" (L/R) to the side frame and align the position mark on top edge of it to a notch on the edge of the side frame.
2. Set "LEVER, PG" to front side (Position "0").
3. Move the carriage assembly to the middle, and put the thickness gauge at the position specified in the figure.
4. Move the carriage assembly over the thickness gauge.

WORK POINT

- ☑ The thickness gauge must be placed on a flat surface of the ribs of "PAPER GUIDE, FRONT;B".
- ☑ During adjustment, always pull the timing belt to move the carriage assembly.

5. Shift the position of "BUSH, PARALLEL ADJUST, RIGHT" to backward (Gap: Narrower) until when the thickness gauge starts sliding together with the carriage assembly when you move it to right and left for about 20mm.
6. At the point of above step, shift the position of "BUSH, PARALLEL ADJUST, RIGHT" for one notch to forward (Gap: Wider).
7. Then, confirm that the thickness gauge do not slide when you move the carriage assembly, with either "LEVER, PG" is at position "0" or "+".

[Paper gap - Left-hand side Adjustment]

8. Repeat the above step 2 to 7 with "BUSH, PARALLEL ADJUST, LEFT".

[Gap Confirmation]

9. Repeat the step 3 to 4 again.
10. Confirm that the thickness gauge do not slide when you move the carriage assembly to right and left for above 20mm.
11. Shift the position of "BUSH, PARALLEL ADJUST, RIGHT" for one notch to backward (Gap: Narrower) and confirm that the thickness gauge is sliding by moving the carriage assembly. If not, return to step 1 and repeat adjustment again.
12. If the gap is correct, shift "BUSH, PARALLEL ADJUST, RIGHT" for one notch to forward (Gap: Wider).

[Fixing "BUSH, PARALLEL ADJUST"]

13. Fix both bushes with 2 screws (1 each : No.1).

When the paper gap adjustment complete, confirm that the overlap of printhead nose and "CLEANER, HEAD".

1. Move the carriage assembly next to "CLEANER, HEAD".
2. Confirm that the overlap of printhead nose and top edge of "CLEANER, HEAD" is more than 0.5mm.

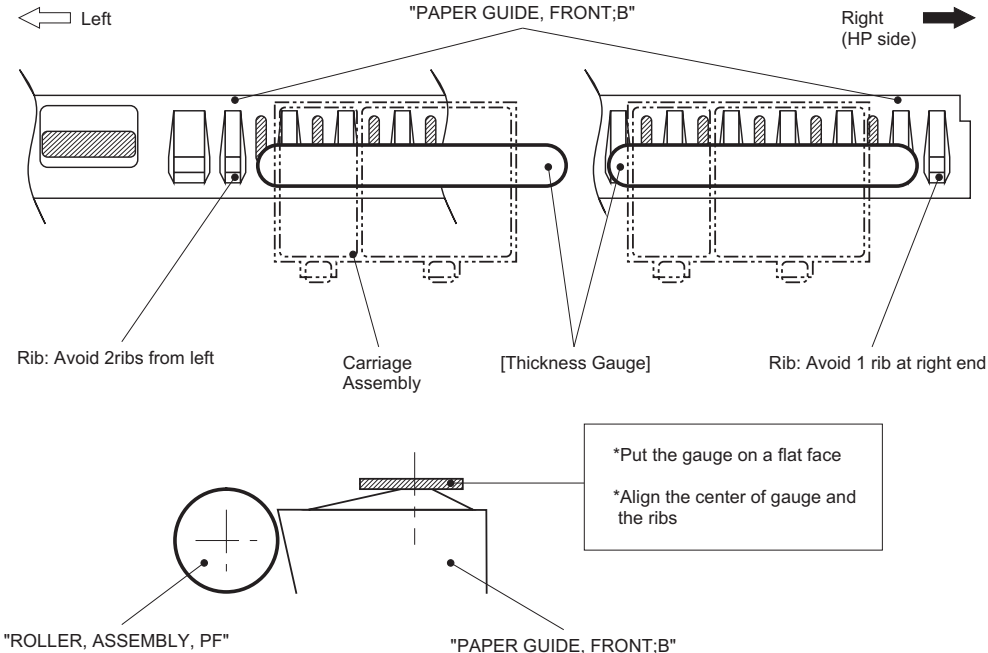

Figure 4-1. Paper Gap Adjustment - Thickness Gauge Setting

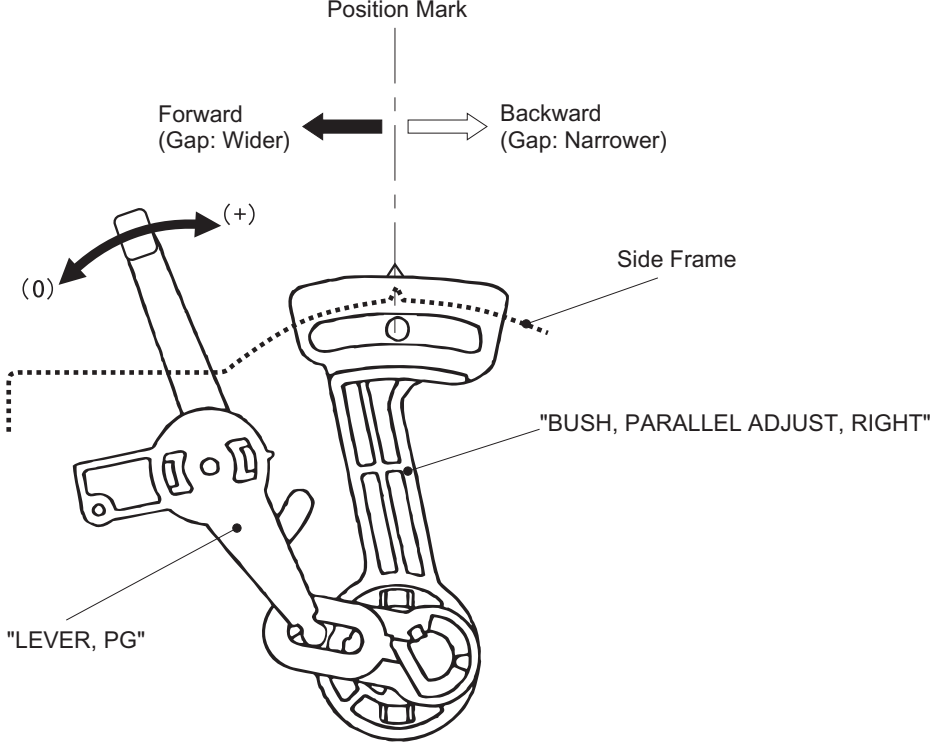

Figure 4-2. Paper Gap Adjustment - Adjustment Procedure

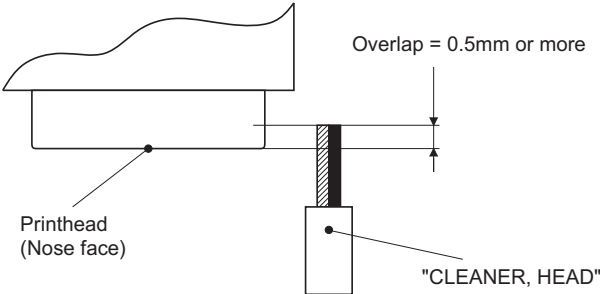

Figure 4-3. "CLEANER, HEAD" Overlap

4.2.2 Adjustment using Adjustment Program

Since the characteristic of printer mechanism and its components are varying, every printer mechanism are checked and it's own characteristic information is stored in EEPROM of the main control board as a compensation parameter for the mechanism control. Therefore, if the combination of printer mechanism and the main control board is changed, the printer should be adjusted using the adjustment program in order to maintain optimum performance of the printer.

4.2.2.1 Overview of Adjustment Program

This adjustment program is developed specifically for this printer and the basic operation with this adjustment program is illustrated in figure below.

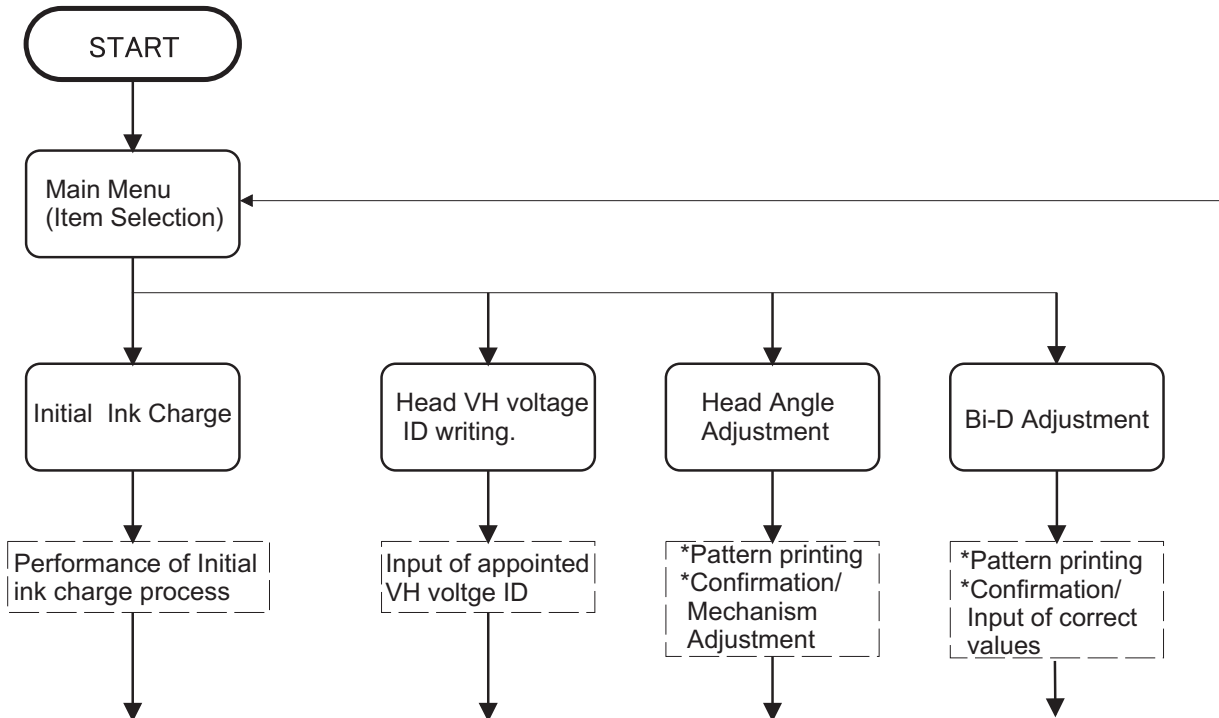

Figure 4-4. Adjustment Program Flow

4.2.2.2 Ink Charge Operation

If either of the following service is made, internal ink paths of the printhead unit is completely empty. Therefore, a brand-new ink cartridge must be installed and all ink paths must be charged with fresh ink by performing the following operation to ensure proper printing operation.

- Replacing the printer mechanism
- Replacing the printhead unit



☑ *Since this operation consumes large amount of ink, do not perform it unnecessarily:*
 *Black: *Approx. 8.8% of the ink charged in the cartridge*
 *Color: *Approx. 16.2% of the ink charged in the cartridge (CMY total)*

1. Re-assemble the printer after replacing the component. (It is enough that, at least, the printer mechanism, the electrical circuits and the control panel are connected.)
2. Connect the PC to the printer and turn the printer on. Then, unpack a brand-new ink cartridges and install them on to the printer.
3. Execute "GW BASIC.EXE" in the floppy diskette and load the adjustment program "J90C00E".
4. Run the program and press ENTER key twice to skip date and time input.
5. At the menu [SCREEN-1], input the number corresponding to your market and press ENTER key.
6. At the menu [SCREEN-2], input "2" to select "Cartridge" and press ENTER key.
7. Then, at the setting menu [SCREEN-3], input "1" to select "(Production)" mode and press ENTER key.
8. When the main menu [SCREEN-4] appear on the screen, input "2" to select "Ink Charge" and press ENTER key. Then, the printer starts the ink charge operation.



The ink charge operation takes long time to complete. Do not turn off the printer until it stops completely. (The POWER indicator blinks during the operation.)

[SCREEN-1]

***** (CUSTOMER) ***** **STYLUS COLOR 600 J90C00E**

1. 000:EUROPE
 2. 010:USA
 3. 020: RUSSIAN

Select No.?_

[SCREEN-2]

***** INK Jig *****

1. Jig
 2. Cartridge

Select No.?_

[SCREEN-3]

***** **SETTING MENU** ***** **J90C00E**

1: (Production)
 2: (Outgoing Inspection)

3: Date/Time [XX-XX-XXXX] [XX:XX:XX]
 4: Jig [CT] JI=JIG CT=Cartridge WAIT=80s
 5: Customer [010:USA]
 6: BI-D Center [0]

JIG: (JIG Maintenance)

Select No.? _

[SCREEN-4]

< **MAIN MENU for Production** > **J90C00E**

1. VH Setting
 2. Ink Charge
 3. Angular Adjust Print XX-XX-XXXX XX:XX:XX
 K. Angular Adjust Setting
 4. Bi-d Adjust [Customer 010: USA]

P. Printing Inspection (GOS) JIG No. :CT
 L. Printing Inspection (S/F) M/C No. :
 M. Printing Inspection (Envelope) HEAD VH :

CL.Cleaning
 9. INK Discharge

E. Go to SETTING MENU *1: (Production)

Select No.?_

4.2.2.3 VH Setting

The piezo-electric element used in each printhead unit has unique electrical characteristic and the electrical characteristic of each printhead is measured at the production and each printhead unit is given with the ID code. Therefore, this ID code is need to be stored in EEPROM on the main board when the following service is made and the printer read this information to compensate the difference of characteristic for printing control and an amount of injected ink is maintained at the specified level.

- Replacing the printhead unit
- Replacing the printer mechanism (the after-service unit comes with the printhead unit installed)

1. When replacing the part mentioned above, take a note of the ID code indicated on the unit as below.

- Printhead Unit: Stamped at the side of the unit
- Printer mechanism: Indicated on a label attached to the packing box for the after-service unit.

2. Re-assemble the printer.

3. Connect the PC to the printer and turn on the printer.

4. Execute "GW BASIC.EXE" from the adjustment program diskette and run "J90C00E".

5. Go to the main menu [SCREEN-4].

6. Input "1" to select "VH Setting" and press ENTER key.

7. At the next menu screen, input "0" as "M/C No." and press ENTER key.

8. Then next menu [SCREEN-5] appear on the screen, and input the ID code which you noted at the beginning of this procedure.

- VH ID Code format:

*1 st /2 nd digits (from left)	=Normal dot VH ID
*3 rd digit	=Drive frequency ID
*4 th /5 th digits	=Micro dot VH ID

9. After inputting the ID code, the program returns to the main menu and you can continue to another adjustments.

WORK POINT

- ☑ *Timing to write the specified value to EEPROM: Upon pressing ENTER key after ID code input.*

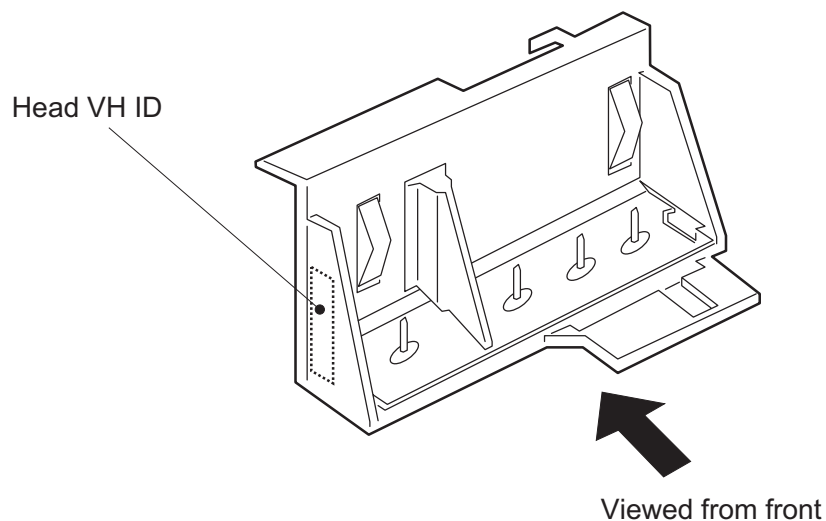

Figure 4-5. Head VH ID Indication

[SCREEN-4]

< MAIN MENU for Production >		J90C00E
1. VH Setting		
2. Ink Charge		
3. Angular Adjust Print	XX-XX-XXXX	XX:XX:XX
K. Angular Adjust Setting		
4. Bi-d Adjust	[Customer	010: USA]
P. Printing Inspection (GOS)	JIG No.	:CT
L. Printing Inspection (S/F)	M/C No.	:
M. Printing Inspection (Envelope)	HEAD VH	:
CL.Cleaning		
9. INK Discharge		
E. Go to SETTING MENU	*1: (Production)	
Select	No.?	_

[SCREEN-5]

<<<< Head VH Setting >>>>	
Head VH(5Col ID (ex. 18109 or 18A09)):	
.....VH CHECK.....	
M/C No.	:XXXXX
HEAD VH	:

4.2.2.4 Head Angular Adjustment

The head angular means the angle at which the printhead unit installed on the carriage assembly against the carriage movement direction and the printhead must be parallel with the carriage movement direction so that the lines printed with each nozzle are evenly positioned. Therefore, this adjustment should be made when the following service is made:

- Replacing or removing the printhead unit

The head angular actually set by the adjust lever installed on the carriage assembly and the program print the check pattern to see the level of head angular.

1. Before performing this adjustment, be sure to perform "VH Setting" (Refer to section 4.2.2.3)
2. At the main menu [SCREEN-4], input "3" to select "Angular Adjust Print" and press ENTER key.
3. Check to see if the lines printed in MAGENTA color is positioned in the middle of two BLACK lines with the check pattern printed by the program. If the position of MAGENTA lines are incorrect, input "K" at the main menu and the carriage assembly moves to the middle of the printer. Then, loosen a screw (No.3) fixing "FASTNER, HEAD" and shift the position of angular adjust level located at the right bottom of the carriage assembly to either forward (move MAGENTA line to down) or backward (move MAGENTA line to up).
4. After adjusting the position of angular adjust lever, input "3" to print the check pattern and verify the angular level. If the level is still not correct, repeat the step 3.
5. If the level is correct, input "K" again and tighten a screw to fix "FASTNER, HEAD". Then, at the menu [SCREEN-6], input "Y" and press ENTER key to complete the adjustment.

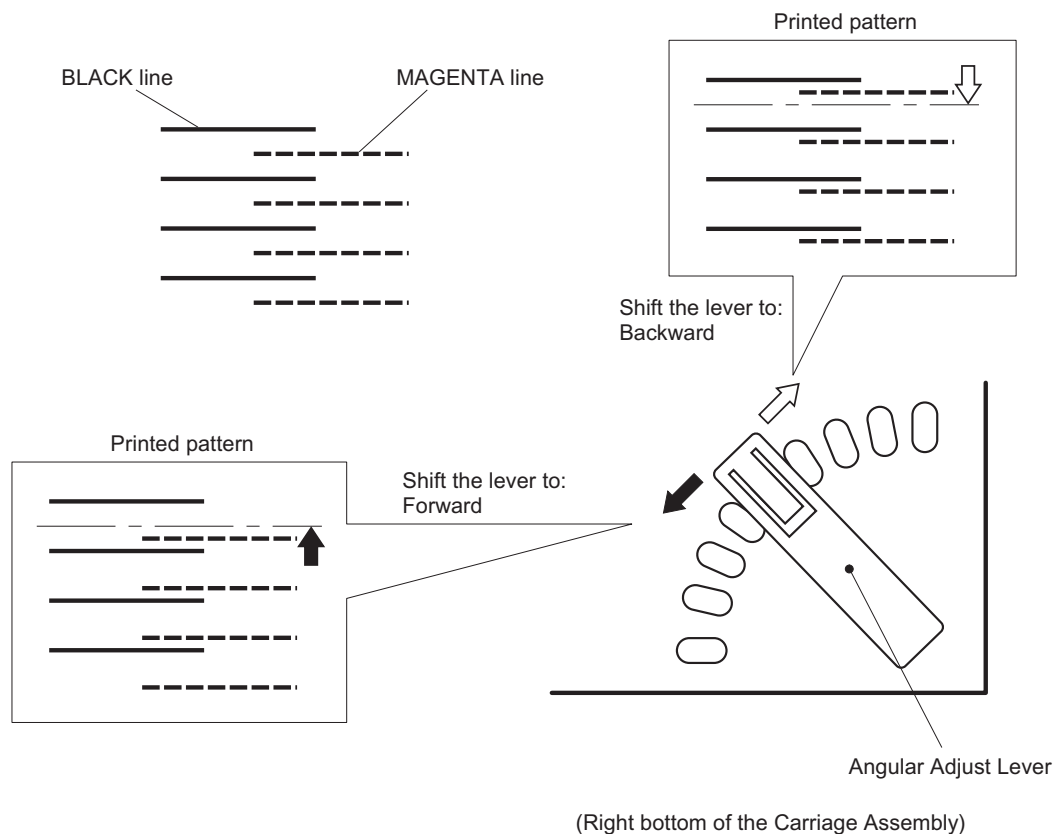

Figure 4-6. Head Angular Adjustment

[SCREEN-4]

< MAIN MENU for Production >		J90C00E
1. VH Setting		
2. Ink Charge		
3. Angular Adjust Print	XX-XX-XXXX	XX:XX:XX
K. Angular Adjust Setting		
4. Bi-d Adjust	[Customer	010: USA]
P. Printing Inspection (GOS)	JIG No.	:CT
L. Printing Inspection (S/F)	M/C No.	:
M. Printing Inspection (Envelope)	HEAD VH	:
CL.Cleaning		
9. INK Discharge		
E. Go to SETTING MENU	*1: (Production)	
Select	No.?	_

[SCREEN-6]

Push Y Key?_

4.2.2.5 Bi-D Alignment Adjustment

This adjustment defines the carriage drive control parameters to compensate the variation in mechanism components characteristic so that the print position become even in bi-directional printing. This adjustment is required when one of the following service is made:

- Replacing the printer mechanism
- Replacing the main board (C200 MAIN)
- Replacing the CR Motor assembly
- Replacing the carriage assembly and related components

The values defined with this adjustment are stored in EEPROM on the main board.

1. If the printer mechanism is replaced, the ink charge operation and the VH Setting operation should be performed prior to this adjustment. (Refer to section 4.2.2.2 and 4.2.2.3)
2. Connect the PC to the printer and turn on the printer.
3. Go to the main menu [SCREEN-4].
4. Input "4" to select "Bi-d Adjust" and press ENTER key.
5. The program prints the check pattern (one with the compensation value="0" and another two patterns each printed with the value "-2" and "+2"). Select the number of the pattern with which the printed lines are most properly aligned, and input the number and press ENTER key at the menu [SCREEN-7]. Then, the program print the sample pattern with the compensation value you have selected.

If all patterns printed by the program are completely mis-aligned, confirm the inclination of misalignment with the pattern printed with the value "0" by checking the relative position of the EVEN line to the ODD line:

- If EVEN line is shifted to RIGHT = Requires (-) value
- If EVEN line is shifted to LEFT = Requires (+) value

Then, once input "Y" and press ENTER key to return to the main menu, and input "E" to select "Go to SETTING MENU" and press ENTER key. At the setting menu screen [SCREEN-3], input "6" to select "BI-D Center" and input the approximation number that corresponding to the inclination of misalignment you have confirmed previously. After changing the reference value for the Bi-D alignment check printing, input "1" to select "(Production)" and back to the main menu and continue for the Bi-D alignment adjustment.

6. If the alignment is correct, input the pattern number at the menu [SCREEN-7] and after completing the sample pattern printing, input "Y" and press ENTER key to define the compensation value.

WORK POINT

Timing to write the specified value to EEPROM: Upon pressing ENTER key after input "Y".

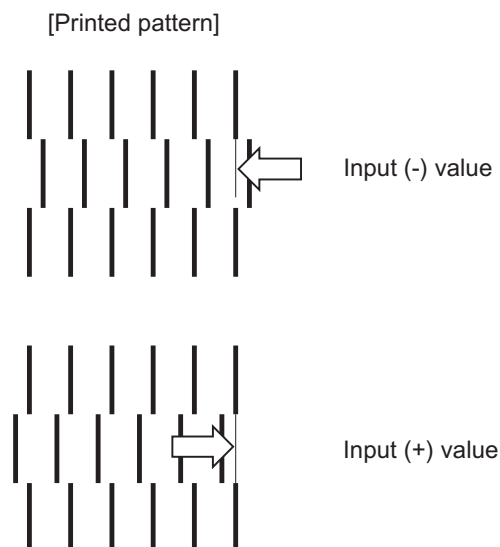

Figure 4-7. Bi-D Alignment

[SCREEN-4]

< MAIN MENU for Production >		J90C00E
1. VH Setting		
2. Ink Charge		
3. Angular Adjust Print	XX-XX-XXXX	XX:XX:XX
K. Angular Adjust Setting		
4. Bi-d Adjust	[Customer	010: USA]
P. Printing Inspection (GOS)	JIG No.	:CT
L. Printing Inspection (S/F)	M/C No.	:
M. Printing Inspection (Envelope)	HEAD VH	:
CL.Cleaning		
9. INK Discharge		
E. Go to SETTING MENU	*1: (Production)	
Select	No.?	_

[SCREEN-7]

INPUT ADJUST No. (IF OK INPUT Y) ?_ ADJUST AREA (-30 to 30)
--

[SCREEN-3]

***** SETTING MENU *****		J90C00E
1: (Production)		
2: (Outgoing Inspection)		
3: Date/Time	[XX-XX-XXXX] [XX:XX:XX]	
4: Jig	[CT] JI=JIG CT=Cartridge WAIT=80s	
5: Customer	[010:USA]	
6: BI-D Center	[0]	
JIG: (JIG Maintenance)		
Select	No.?	_

Chapter 5

Troubleshooting

5.1 Troubleshooting	5-1
5.2 Unit Level Troubleshooting	5-3
5.2.1 Printer does not operate at power on	5-4
5.2.2 Error is detected.....	5-5
5.2.3 Failure occurs during printing	5-6
5.2.4 Printer does not feed the paper correctly.....	5-7
5.2.5 Control panel operation is abnormal	5-8
5.3 Unit Repair C206 PSB/PSE Board	5-9
5.3.1 Unit Repair - C200 Main Board	5-11
5.4 Repair of the Printer Mechanism.....	5-13

5.1 Troubleshooting

The printer may exhibit different symptoms for the same problem, which makes troubleshooting more difficult. This section, however, provides simple and effective ways to facilitate troubleshooting. The following flowchart illustrates the main steps of the trouble shooting process.

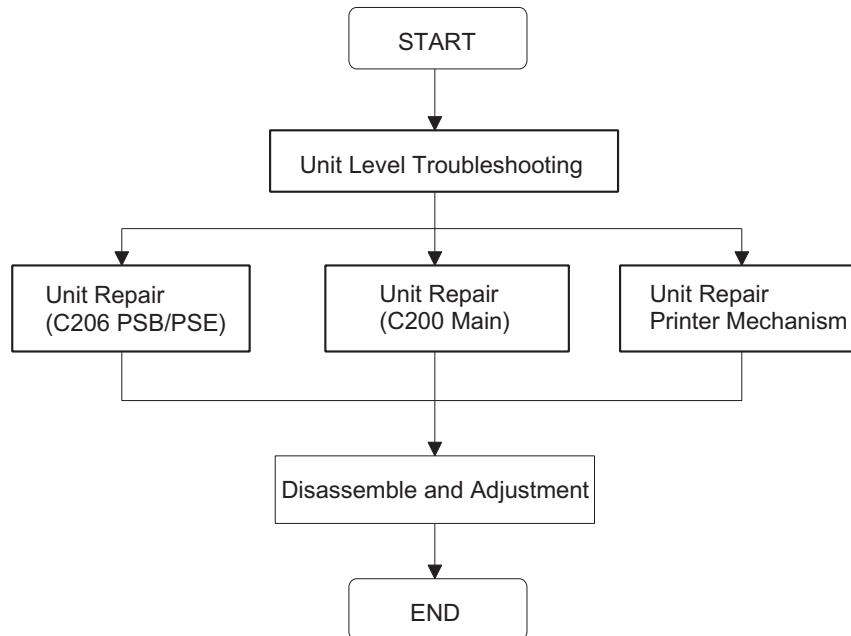

Figure 5-1. Troubleshooting Process Flowchart

Table 5-1. Motor Resistance and Measurement Procedure

Motor Name	Location	Check Point	Resistance
CR Motor	CN6(C200 Main)	1-pin & 3-pin, 2-pin & 4-pin	$7.8f\Omega \cdot \} 10\%$
PF(Pump) Motor	CN7(C200 Main)	1-pin & 3-pin, 2-pin & 4-pin	$7.8f\Omega \cdot \} 10\%$

Table 5-2. Sensor Check

Sensor Name	Check Point	Signal Level	Sensor Status
Paper end sensor	CN4 / 1-pin, 2-pin	Open: less than 0.7 V	Paper exit
		Close: more than 2.4 V	No paper
Carriage home position sensor	CN5 / 1-pin, 2-pin	Open: less than 0.7 V	Home position
		Close: more than 2.4V	Out of home position
ASF phase Sensor	CN11 / 1-pin, 2pin	Open: less than 0.7 V	Home position
		Close: more than 2.4 V	Out of home position
Black cartridge sensor	CN8 / 1-pin, 18pin	On: 0 V	Black cartridge out
		Off: more than 2.4 V	Black cartridge exit
Color cartridge sensor	CN8 / 2-pin, 18-pin	On: 0 V	Color cartridge out
		Off: more than 2.4 V	Color cartridge exit
Thermistor	CN8 / 3-pin, 18-pin	Analog data	Change the VH voltage of charge pulse for common driver circuit

Table 5-3. Printer Condition and Panel Status

Error status	Indicators				Recovery
	Power	Ink Out (Black)	Ink Out (Color)	Paper Out	
Paper Out	---	---	---	On	Load paper by pressing load/eject button.
Paper jam condition	---	Off	Off	Blink	Eliminate a paper then press load/eject button.
No Ink cartridge or Ink end(black)	---	On	---	---	Install a new black ink cartridge by pressing load/eject button for 3-seconds.
No Ink cartridge or Ink end(color)	---	---	On	---	Install a new color ink cartridge by pressing load/eject button for 3-seconds.
Maintenance request	Blink	Blink	Blink	Blink	Change the waste ink drain tank and reset the EEPROM.
Fatal error	Blink	On	On	Blink	Turn on the printer and turn it on again. If printer can not recover, repair the suitable part.

5.2 Unit Level Troubleshooting

When a problem occurs, you can identify the defective unit according to the symptoms exhibited. The table below lists the symptoms of certain problems. Once the problem is identified, refer to the flowchart that corresponds to the problem.

Table 5-4. Symptom and Problem

Symptom	Problem	Flowchart No.
Printer does not operate at power on	<ul style="list-style-type: none"> • ; LEDs do not light up. • ; Printer mechanism does not operate. 	Section 5.2.1
Error is detected	<ul style="list-style-type: none"> • ; Error is indicated by LED indication. 	Section 5.2.2
Failure occurs during printing	<ul style="list-style-type: none"> • ; Printing is not performed. • ; Abnormal printing(missing dot, etc.) • ; Print quality is poor 	Section 5.2.3
Printer does not feed the paper correctly	<ul style="list-style-type: none"> • ; No paper is fed. • ; Paper feed is irregular. • ; Paper jam occurs. 	Section 5.2.4
Control panel operation is abnormal	<ul style="list-style-type: none"> • ; No response to button access. 	Section 5.2.5

5.2.1 Printer does not operate at power on

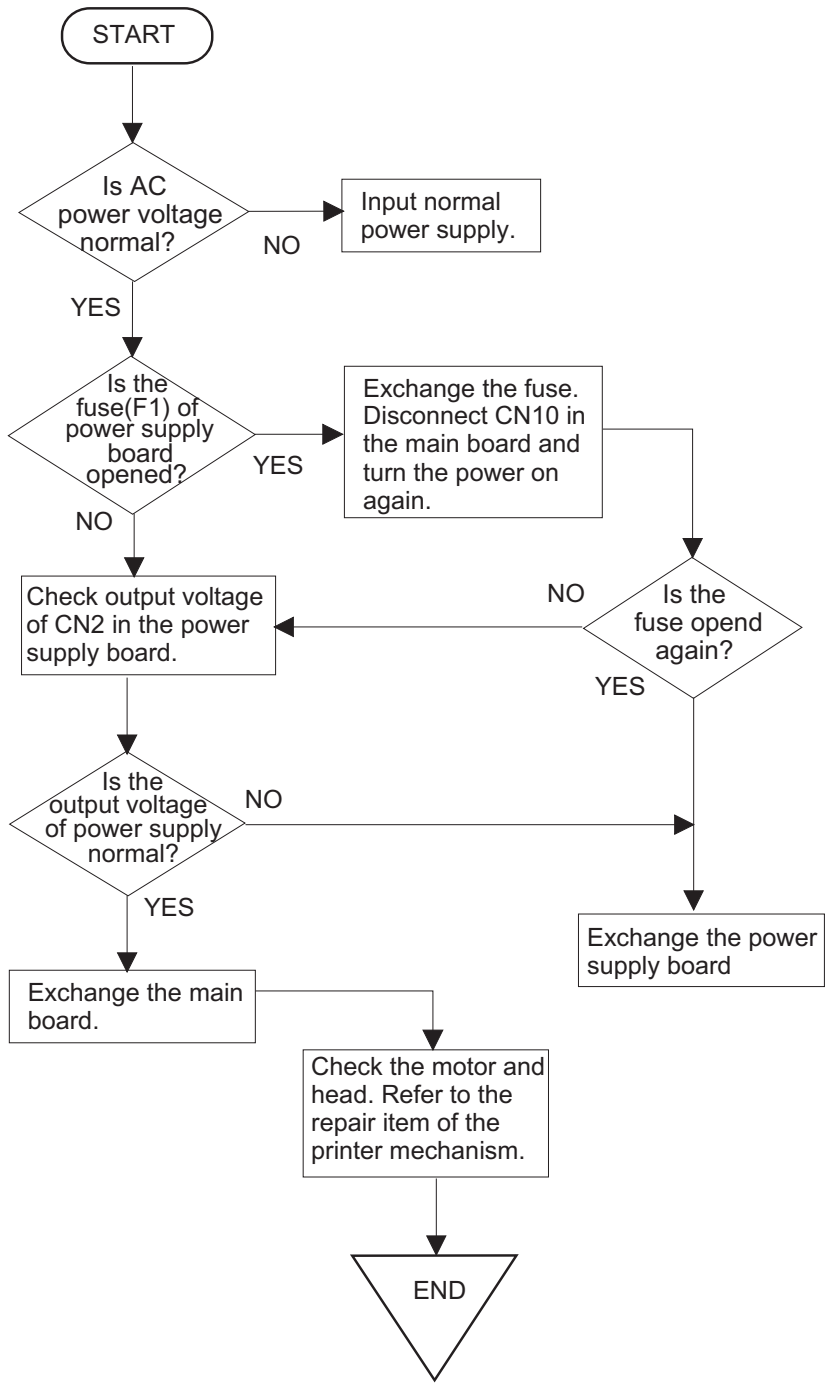

Figure 5-2. Flow Chart 1

5.2.2 Error is detected

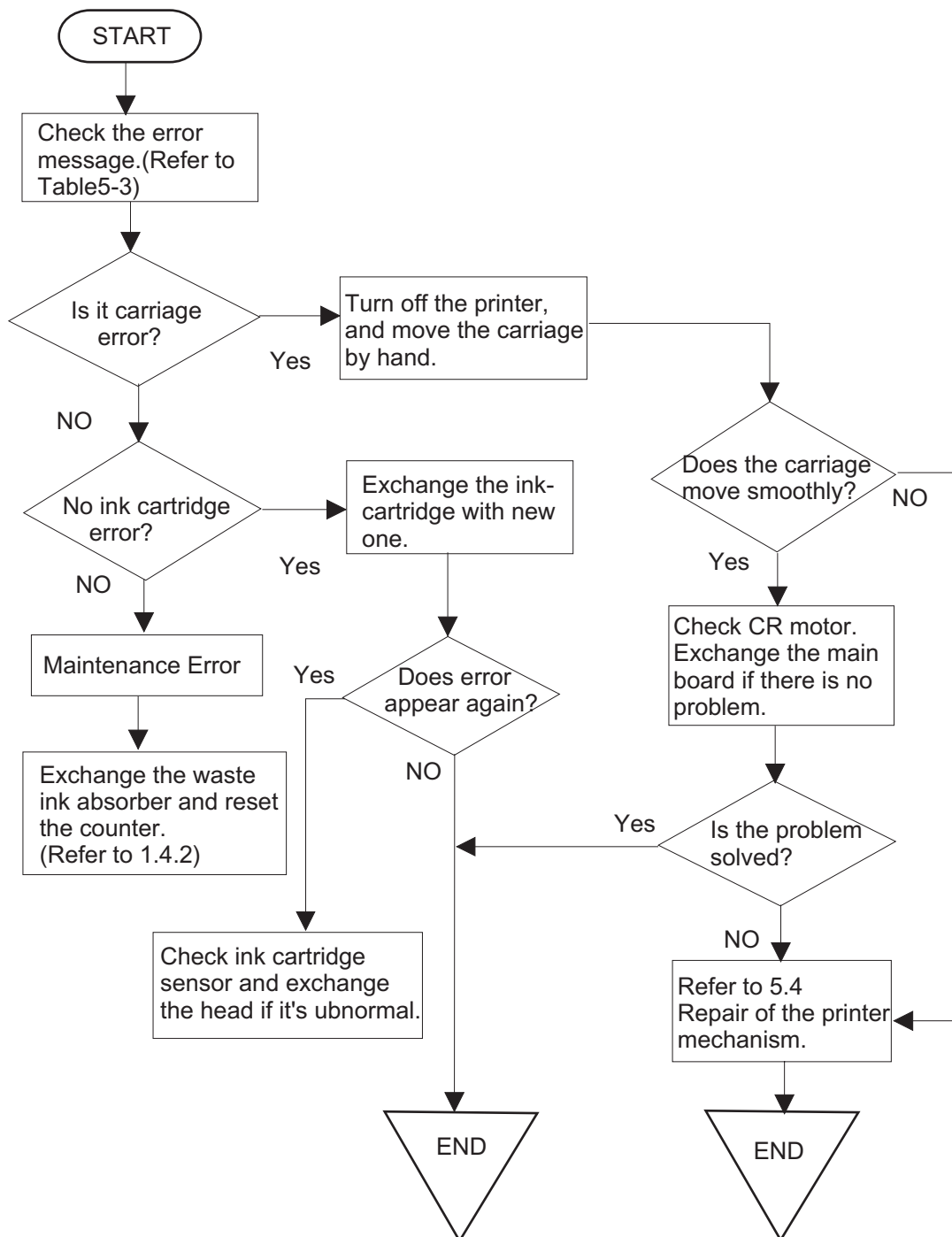

Figure 5-3. Flow Chart 2

5.2.3 Failure occurs during printing

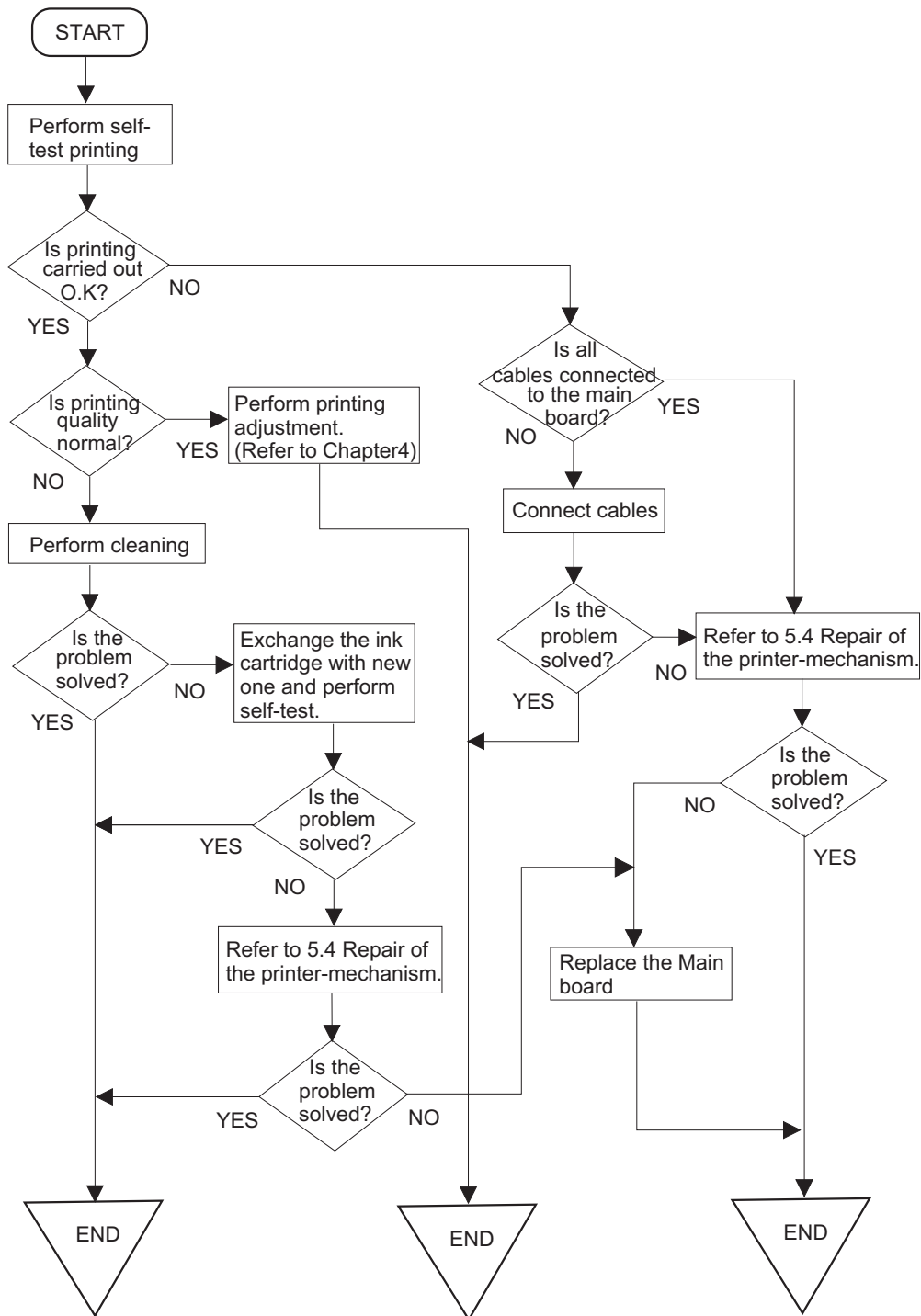

Figure 5-4. Flow Chart 3

5.2.4 Printer does not feed the paper correctly

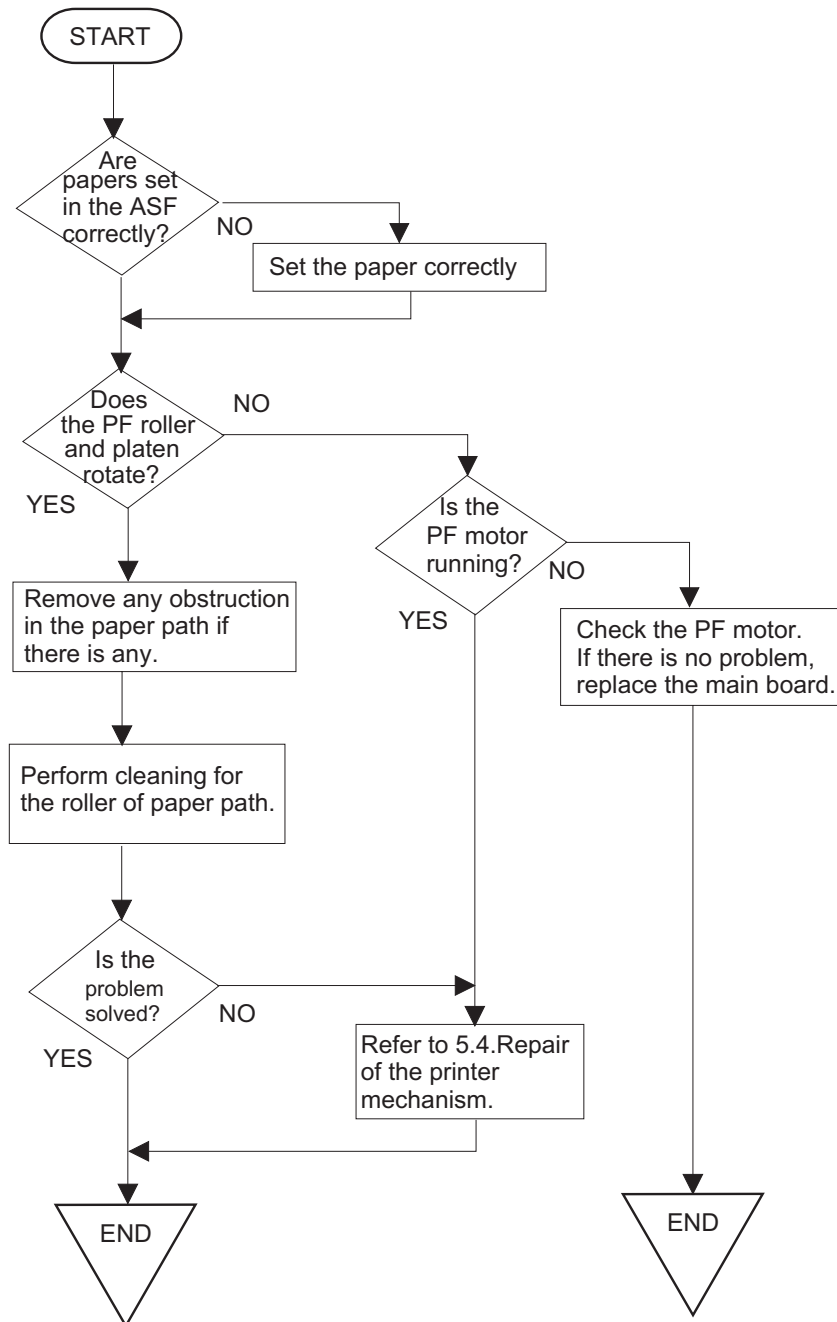

Figure 5-5. Flow Chart 4

5.2.5 Control panel operation is abnormal

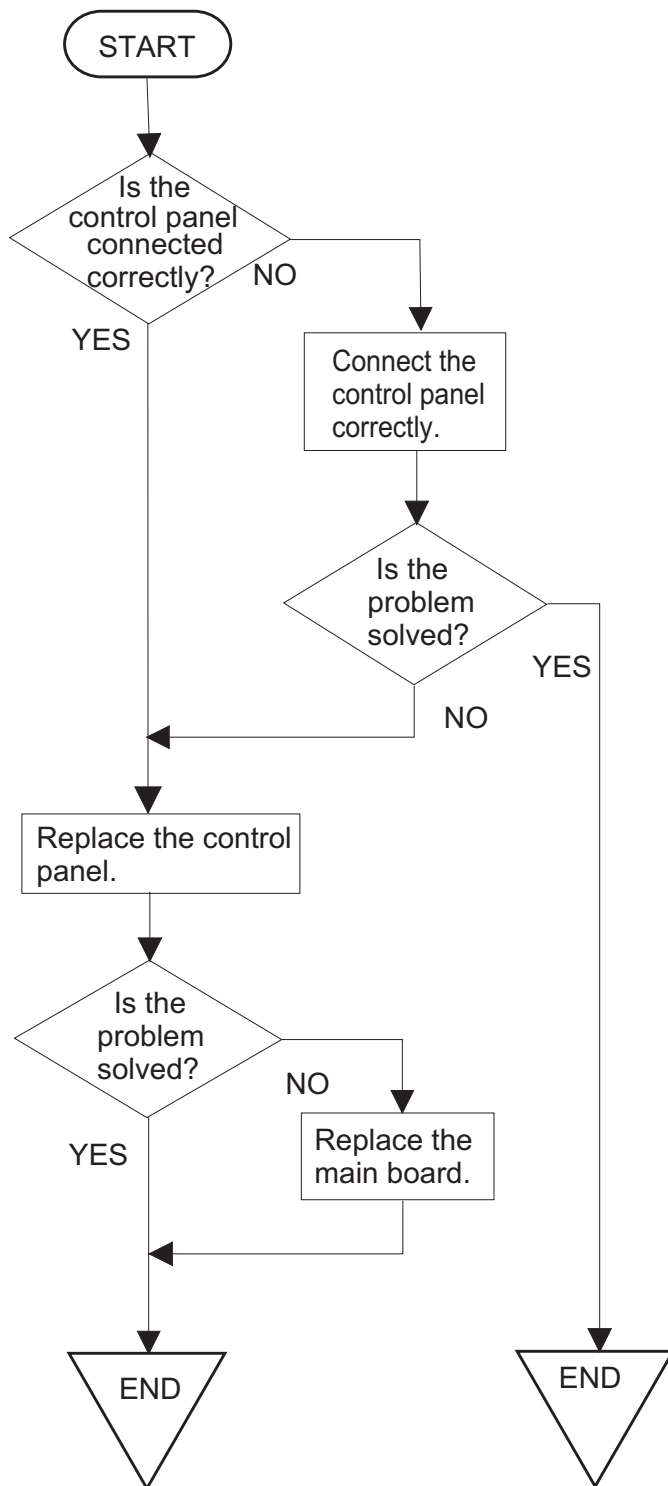

Figure 5-6. Flow Chart 5

5.3 Unit Repair C206 PSB/PSE Board

This section describes the problems related to the power supply board(C206 PSB/PSE). The table next page provides various symptoms, likely causes, and checkpoints. The checkpoints refer to waveforms, resistance, and other values to be checked to evaluate the operation of each component.

Table 5-5.C206PSB Power Supply Board

Symptom	Condition	Cause	Checkpoint	Solution
The printer does not operate at all.	+42V line is dead.	F1 is open.	Check F1 by using a tester. 	Replace F1.
		Transformer coils are open.	Check the waveform at the drain of Q1.	Replace T1.
		Switching FET (Q1) is dead.	Check drain side. 	Replace Q1.
		Feed back transistor(Q2, Q3) are dead.	Check corrector side. 	Replace Q2 or Q3.
		+42 V line is abnormal.	Check following parts. •ZD87, ZD83 •ZD51,ZD81•`ZD86 •PC1	Replace suitable parts.

Table 5-6. C206PSB Power Supply Board (Con.)

Symptom	Condition	Cause	Checkpoint	Solution
	+5V line is dead.	IC51 (L4962E) is dead.	<p>Check the oscillation(5-pin) and switching (7-pin) waveform of IC51.</p> <p>(5-pin)</p>  <p>(7-pin)</p> 	Replace IC51.

5.3.1 Unit Repair - C200 Main Board

This section describes the problems related to the main controller board(C200 main). The table below provides various symptoms, likely causes, and checkpoints. The check points refer to waveforms, resistance, and other values to be checked to evaluate the operation of each component.

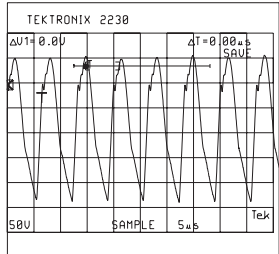
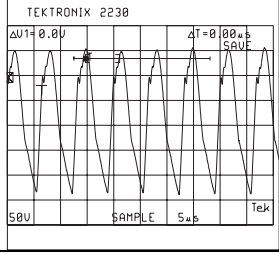
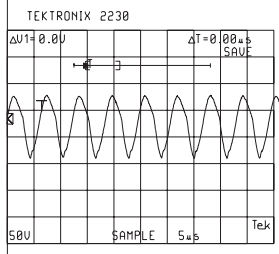
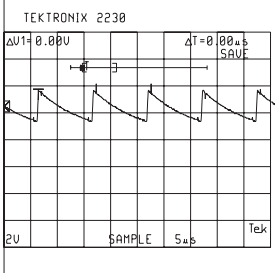
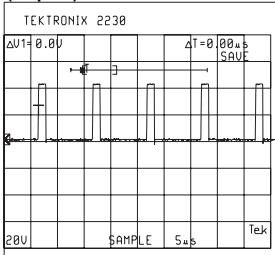
Symptom	Condition	Cause	Checkpoint	Solution
The printer does not operate at all.	CPU does not operate.	The reset circuit does not operate.	Check the waveform of the +5V and /Reset signal (IC8=5,1-pin/IC9=7,6-pin) 	Replace IC8 or IC9.
		Control ROM is not selected correctly or it's dead.	If you can not find the waveform at 2-pin of IC3, the IC1 is dead, and if you can not find it at 20-pin of IC3, the IC3 is dead.	Replace IC1 or IC3.
		RAM is not selected correctly or it's dead.	If you can not find the waveform at 29,14-pin of IC4, the IC1 is dead, and if you can not find it at 28-pin of IC4, the IC4 is dead.	Replace IC1 or IC 4.
		CRU2 is dead.	Check the waveform at 27,28-pin of IC1. 	Replace the CRU2.
The carriage does not operate normally.	Carriage motor does not operate at all.	IC2 is dead.	Check the waveform at 72,73 and 75,76 pin of IC14. 	Replace IC2.
		IC14 is dead.	Check the waveform at 6-9 pin if IC14. 	Replace IC14.

Table 5-7. Repair of the C200 Main Board

Table 5-8. Repair of the C200 Main Board(Con.)

Symptom	Condition	Cause	Checkpoint	Solution
Printing is abnormal.	Printing is not execute.	IC7 is dead.	Check the trapezoidal waveform at 3-pin of Q7 on C200main board.	Replace IC6, Q7, or Q9.
		IC2 is dead.	Check the control signal of trapezoidal from IC2. (at 80 pin of IC2)	Replace IC2.
Paper feed operation is abnormal.	Paper feed motor does not work.	IC2 is dead.	Check the output waveform of at 55, 56, 57, 58 pin of IC2.	Replace IC2
		IC15 is dead.	Check the output waveform of at 6, 7, 8, 9 pin of IC15.	Replace IC15

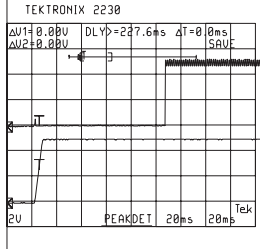
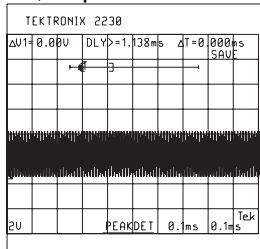
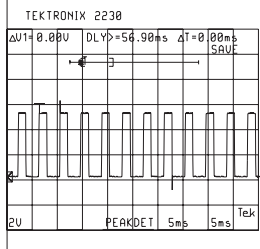
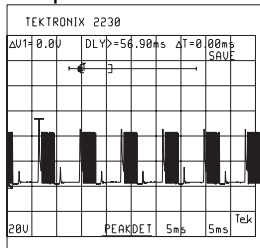
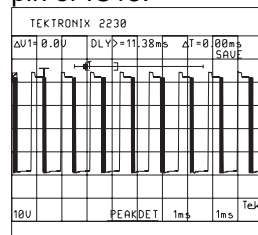
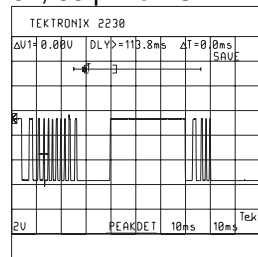
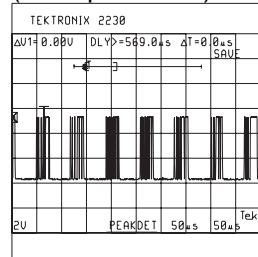

5.4 Repair of the Printer Mechanism

This section provides instruction for repairing the printer mechanism. It describes various problems, symptom, likely causes, checkpoints, and solutions. Select appropriate symptom from the table and check each parts and its function as described in the checkpoint.

Table 5-9. Repair of the Printer Mechanism

Symptom	Condition	Cause	Checkpoint	Solution
Abnormal pump mechanism operation	Abnormal PF motor operation when the power is turned on.	Foreign substances are loaded in the PF gears.	Manually drive the platen drive gear and check it if it rotates normally.	Remove any foreign substances.
		The PF motor is defective. (Refer to Table5-1)	Check the inner coil resistance and see if there is any disconnection of the coil.	Exchange the PF motor.
Ink is not absorbed or is poorly absorbed.	Used ink does not go through the waste ink tube.	The pump tube is crashed.	Check the tube visually.	Fix the crashed part by the airgun.
		Capping rubber is damaged or deformed.	Check the capping rubber visually.	Replace the cap mechanism.
		The tube is out of the cap.	Check if the tube is out of the cap visually.	Connect the tube properly.
		Pump bulb is not closed at absorption.	Check the bulb operation visually.	Replace the cap mechanism.
Abnormal carriage operation.	Abnormal carriage operation at power on.	Foreign substance in the CR drive gear.	Check visually if there is any substances or not.	Remove any foreign substances.
		CR motor is defective.	Check the inner coil resistance and see if there is any disconnection of the coil.	Replace the CR motor.
	Abnormal carriage operation during printing.	Carriage movement is not smooth.	Check whether the carriage moves smoothly when moved manually.	Clean and lubricate the carriage guide axis.
Check tension of the timing belt.			Adjust tension mechanism or exchange it.	
Check if there is any foreign substances in the carriage path.			Remove any foreign substances.	
Printing is not performed.	The carriage moves, but no printing is performed.	Head FFC is out of connection.	Check if the head FFC on the board or carriage is connected surely.	Connect the FFC properly.
		The FFC is disconnected inside.	Check the FFC by using a tester.	Replace the FFC.
		I/C is defective.	Install a new I/C and perform the self-test.	Replace I/C.
		Head unit is defective.	If the condition does not improve even after 2or 3 times cleaning operation, replace the head unit and perform the self-test.	Replace the head unit.

Table 5-10. Repair of the Printer Mechanism (Con.)

Symptom	Condition	Cause	Check-point	Solution
Abnormal printing	Only a particular dot causes abnormal printing.	Print head surface is not clean. (dot missing)	Perform the cleaning operation several times and check printing.	Perform the cleaning.
		The head unit is defective.	Perform the cleaning operation several times and check printing.	If condition does not improve even after the cleaning, replace the head.
		Capping absorber is touching the head surface.	Check the head absorber visually.	Replace the head absorber if it is deformed.
	A dot is not printed occasionally.	Print head surface is not clean. (dot-missing)	Perform the cleaning operation several times and check printing.	Perform the cleaning.
		The head FFC is disconnected inside.	Check the FFC by using a tester.	Replace the head FFC.
		The head FFC is out of connection.	Check if the head FFC on the board or carriage is connected surely.	Connect the FFC properly.
		The head unit is defective.	Perform the cleaning operation several times and check printing.	If condition does not improve even after the cleaning, replace the head.
		I/C is defective.	Install the new I/C and perform self-test.	Replace I/C.
	Black specks or dots.	The head FFC is out of connection.	Check if the head FFC on the board or carriage is connected surely.	Connect the FFC properly.
		The head unit is defective.	Check connection with the head FFC.	Replace the head if there is no connection problem with the FFC.
	A vertical line is not aligned.	Bi-directional alignment is not adjusted.	Perform Bi-D adjustment.	Refer to Chapter4.
	White line appears in the image data.	Head angle is not correct.	Perform head angle adjustment.	Refer to Chapter4.
		Platen gap is not correct.	Perform platen gap adjustment.	Refer to Chapter4.
		Dot shooting direction is tilted because head surface is not clean	Perform the cleaning operation several times and check printing.	Perform the cleaning operation.
		I/C is defective.	Install a new I/C and perform the self-test.	Replace I/C.
Head unit is defective.		Perform the cleaning operation several times and check printing.	Replace the head unit.	

Table 5-11. Repair of the Printer Mechanism (Con.)

Symptom	Condition	Causes	Checkpoint	Solution
Abnormal paper feeding.	Paper is not fed.	Friction of the PF roller.	Check if the PF roller rotates when paper is not fed.	Clean the PF roller by the cleaning sheet. Replace the PF roller if it does not recover.
		Abnormal operation of the hopper.	Check movement of the ASF hopper visually.	Replace ASF.
		Malfunction of ASF drive change-over.	Check if the ASF gear rotates visually.	Replace gears of the ASF drive change-over.
		Friction of the PF roller.	Check if the PF roller slips during paper feeding.	Clean the PF roller by the cleaning sheet. Replace the PF roller if it does not recover.
Printer stops during initialization.	Fatal error appears.	ASF sensor is defective.	Check the signal level of the ASF sensor.(Refer to Table 5-2)	Replace ASF sensor.
		PE sensor is defective.	Check the signal level of the PE sensor.(Refer to Table 5-2)	Replace PE sensor.
		HP sensor is defective.	Check the signal level of the HP sensor .(Refer to Table 5-2.)	
		Head FFC is disconnected.	Check if the head FFC is connected.	Connect the head FFC.
		CR motor is defective.	Check the CR motor cable is connected.	Replace the CR motor if there is no problem in the cable connection.
		PF motor is defective.	Check if the PF motor cable is connected.	Replace the PF motor if there is no problem in the cable connection.

Chapter 6 Maintenance

- 6.1 OVERVIEW 6-1
 - 6.1.1 Cleaning..... 6-1
 - 6.1.2 Service Maintenance 6-1
 - 6.1.3 Lubrication 6-2

6.1 OVERVIEW

This section describes the points and the procedures for maintaining the printer in its optimum condition.

6.1.1 Cleaning

This printer has no mechanical components requiring regular cleaning. Therefore, the points described below are suggested to be checked for any dirt and make an appropriate cleaning if necessary.



- Never use the chemical solvents, such as thinner, to clean the printer. These chemicals can damage the components of the printer.*
- Be careful not to damage the components when you attempt to clean the inside of the printer.*
- Do not scratch surface of "ROLLER, ASSEMBLY, PF".
(Use soft brush to wipe off any dusts, or use soft cloth moistened with alcohol)*

- Housing:** Use clean soft cloth moistened with water and wipe off any dirt. If the housing stained with an ink, use a cloth moistened with a neutral detergent to wipe it off.
- Inside the printer:** Use a vacuum cleaner to remove any paper dust.

6.1.2 Service Maintenance

If the print irregularity (missing dot, white line, etc.) has occur or the printer indicates "MAINTENANCE ERROR", perform the following operation to clear the error.

Head Cleaning

1. The printer has a built-in head cleaning function and is executable from the control panel.
2. Confirm that the printer is in stand-by state (the POWER indicator is not blinking), and hold down the cleaning button on the control panel for more than 3sec.
3. The printer perform the built-in cleaning sequence. (during cleaning operation, the POWER indicator is blinking)

Maintenance Error Clear

Since the printer consumes the ink, not only for printing but also for another operation like cleaning, certain amount of ink are wasted. Therefore, the printer counts the amount of waste ink and they are collected at the waste ink pad, and once the amount of waste ink reaches the predefined limit, the printer indicates "MAINTENANCE ERROR" and the waste ink pad should be replaced as follows:

1. Replace the waste ink pad to new one.
2. After re-assemble the printer, turn the printer on while hold down the following buttons on the control panel:
 - E"LOAD/EJECT" button
 - E"CLEANING" button
3. Press "LOAD/EJECT" button again while "PAPER END" indicator is blinking. This clears the maintenance error condition and the waste ink counter value stored in EEPROM of the main board.

6.1.3 Lubrication

The type and amount of oil and grease used on this printer are determined based on the results of internal evaluations. Therefore, specified type and amount of oil and grease must be applied at specified part of the printer mechanism when servicing the printer.



- ✓ Never use the oil and the grease other than those specified in this manual and using different type of lubricant can damage the printer and the components.
- ✓ Never apply oil or grease exceeding the amount specified in this manual.

Table 6-1. Specified Lubricants

Type	Name	EPSON Code	Supplier
Grease	G-26	B702600001	EPSON
Oil	O-8	1019753	EPSON

Table 6-2. Lubrication Points

No.	Standard	Remarks
1	<Lubrication Point> Contact between "ROLLER, PF" and "PAPER GUIDE, REAR"	<ul style="list-style-type: none"> ● Apply grease while rotating "GEAR, 67.2". ● Do not put grease around the paper path. ● Use a syringe to apply it.
	<Lubricant Type> G-26	
	<Lubrication Amount> A half turn of "ROLLER, PF"	
2	<Lubrication Point> "Contact between "PAPER GUIDE, FRONT" and each rollers: 1) "ROLLER, PF" (1 point) 2) "ROLLER, EXIT" (2 points)	<ul style="list-style-type: none"> ● Apply to the contact of a hook of "PAPER GUIDE, FRONT" and each roller. ● Do not put grease around the paper path. ● Use a syringe to apply it.
	<Lubricant Type> G-26	
	<Lubrication Amount> 1) 10mm long 2) 2mm long	
3	<Lubrication Point> Contact between the carriage assembly and "FRAME, UPPER"	<ul style="list-style-type: none"> ● Verify that the carriage moves smoothly after lubricating it. ● Use a syringe to apply it.
	<Lubricant Type> G-26	
	<Lubrication Amount> From the HP sensor installation point to the point where "GUIDE PLATE, CABLE" is attached.	
4	<Lubrication Point> Gears: 1) "GEAR, 67.2" 2) "COMBINATION GEAR, 8, 14.4" 3) "GEAR, 23.2"	<ul style="list-style-type: none"> ● Rotating the gears after applying grease to evenly distribute it. ● Use a syringe to apply it.
	<Lubricant Type> G-26	
	<Lubrication Amount> 1) 1/4 of gear tooth 2) 1/3 of gear tooth 3) 1/3 of gear tooth 4) 1/3 of gear tooth	

Table 6-3. Lubrication Points (Continued)

No.	Standard	Remarks
5	<Lubrication Point> The shaft for "GEAR, 16, 40.8" at "FRAME, LEFT"	<ul style="list-style-type: none"> ● Use a syringe to apply it.
	<Lubricant Type> G-26	
	<Lubrication Amount> Approx. 5mm long	
6	<Lubrication Point> Bush for "ROLER, PF" 1) Left: Inside the bush 2) Right: Inside the bush (near the pump assembly)	<ul style="list-style-type: none"> ● When applying to the right bush, apply it from the side of the paper path and wipe off any grease stick out to the cap assembly side. ● Rotate "ROLLER, PF" after applying the grease to evenly distribute it in the bush. ● Use a syringe to apply it.
	<Lubricant Type> G-26	
	<Lubrication Amount> Approx. 3mm diametrically	
7	<Lubrication Point> Both Left/Right Bush for "ROLLER, EXIT"	<ul style="list-style-type: none"> ● Do not put grease around the paper path. ● Use a syringe to apply it.
	<Lubricant Type> G-26	
	<Lubrication Amount> Evenly apply inside the bush	
8	<Lubrication Point> Contact between "HOLDER, PULLEY, DRIVEN" and "FRAME, UPPER"	<ul style="list-style-type: none"> ● Verify that the holder slides only with a spring force after applying the grease. ● Use a syringe to apply it.
	<Lubricant Type> G-26	
	<Lubrication Amount> 2mm long at each specified point	
9	<Lubrication Point> ASF; A round hole of the right frame of ASF (to hold the roller shaft)	<ul style="list-style-type: none"> ● Do not put grease to "ROLLER, ASSEMBLY, LD".
	<Lubricant Type> G-26	
	<Lubrication Amount> Evenly apply inside the hole	
10	<Lubrication Point> ASF; Contact between "HOPPER" and "LEVER, HOPPER, RELEASE"	<ul style="list-style-type: none"> ● Completely wipe off any grease stack out to inner side of ASF.
	<Lubricant Type> G-26	
	<Lubrication Amount> Evenly apply to the contact	

Table 6-4. Lubrication Points (Continued)

No.	Standard	Remarks
11	<Lubrication Point> A round hole of the left frame of ASF ("GEAR, 34" is inserting to this hole)	<ul style="list-style-type: none"> ● Completely wipe off any grease stack out to inner side of ASF.
	<Lubricant Type> G-26	
	<Lubrication Amount> Evenly apply inside the hole	
12	<Lubrication Point> Oil pad of carriage assembly	<ul style="list-style-type: none"> ● This application must be made only when; <ul style="list-style-type: none"> *Replacing the carriage assembly *Replacing oil pad ● Use a precise syringe to apply it. If accidentally apply too much oil to oil pad, thrown it away and take a new oil pad again. ● Leave oil pad for a while to wait until oil is evenly infiltrate and install it on the carriage assembly.
	<Lubricant Type> O-8	
	<Lubrication Amount> 0.6cc	
	<i>Note that This is an amount to be applied new oil pad when replacing it.</i>	



☑ *Never apply oil to the CR guide shaft directly or additionally apply to oil pad. This may cause fatal damage to the components of the printer.*

****Never apply the oil exceeding 0.6cc.***

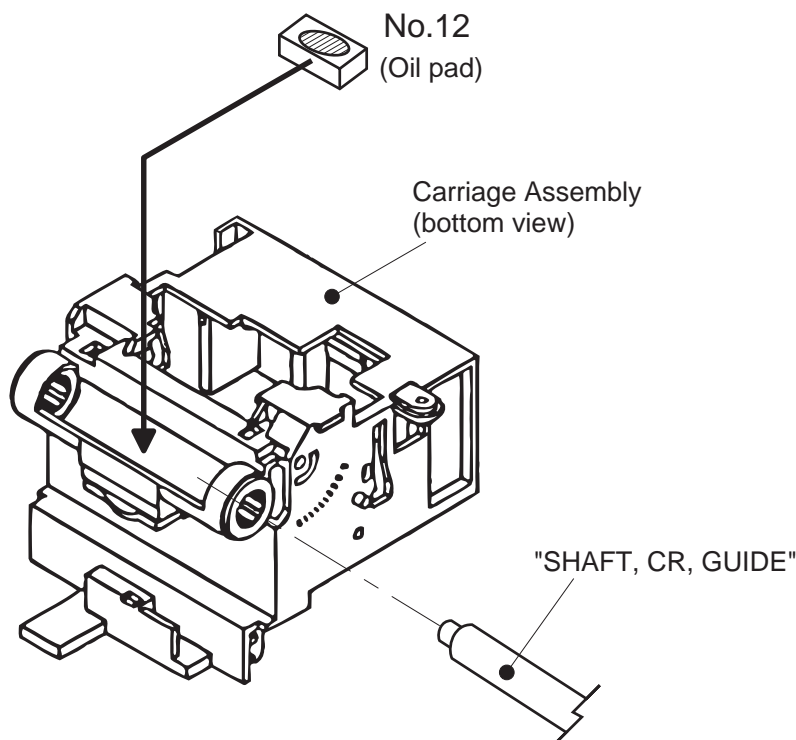

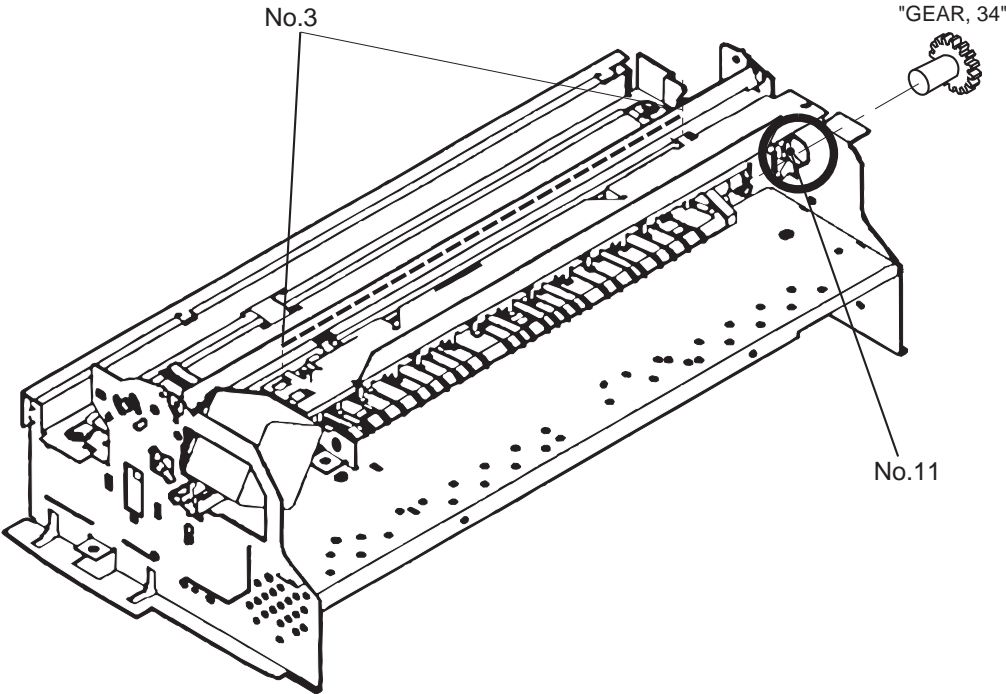
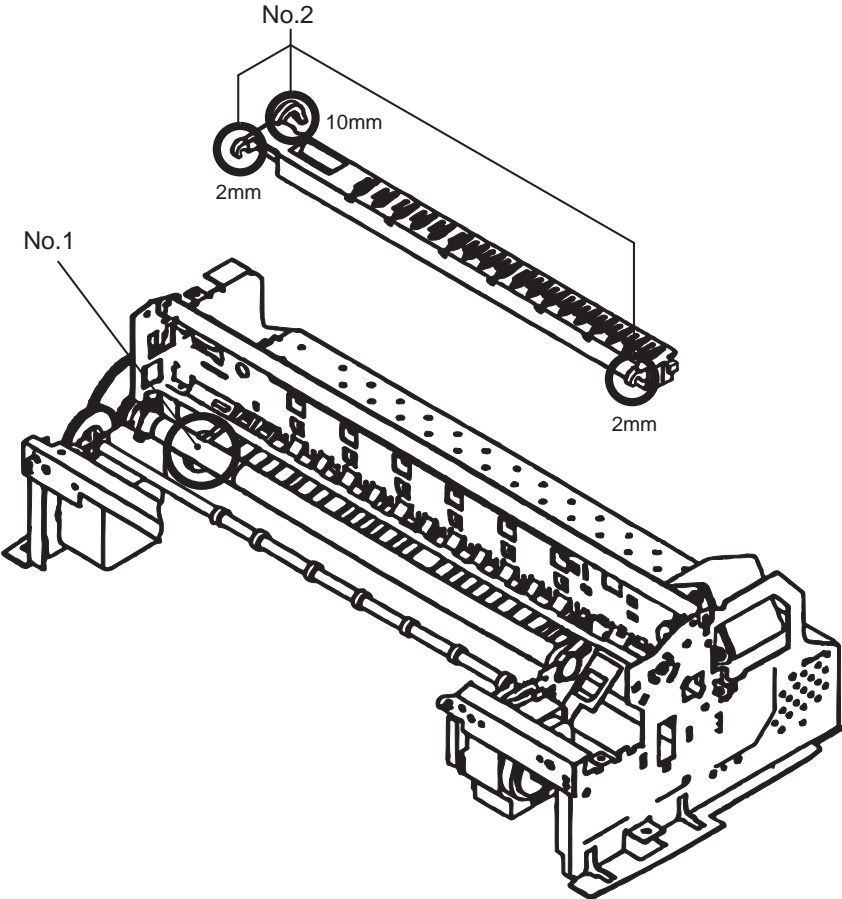

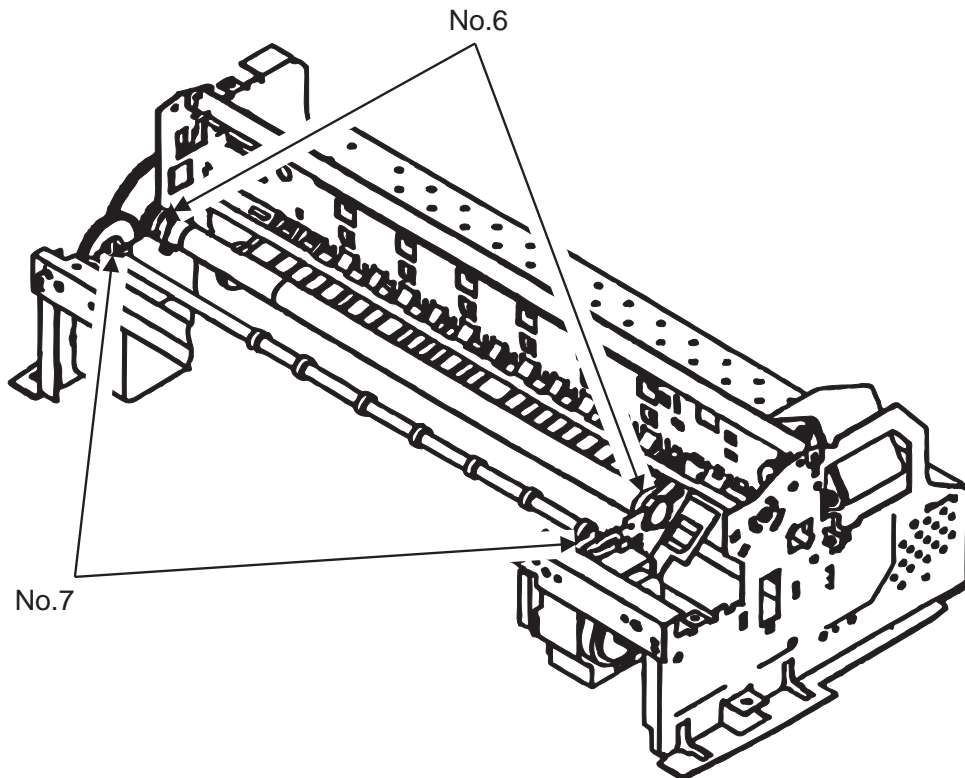
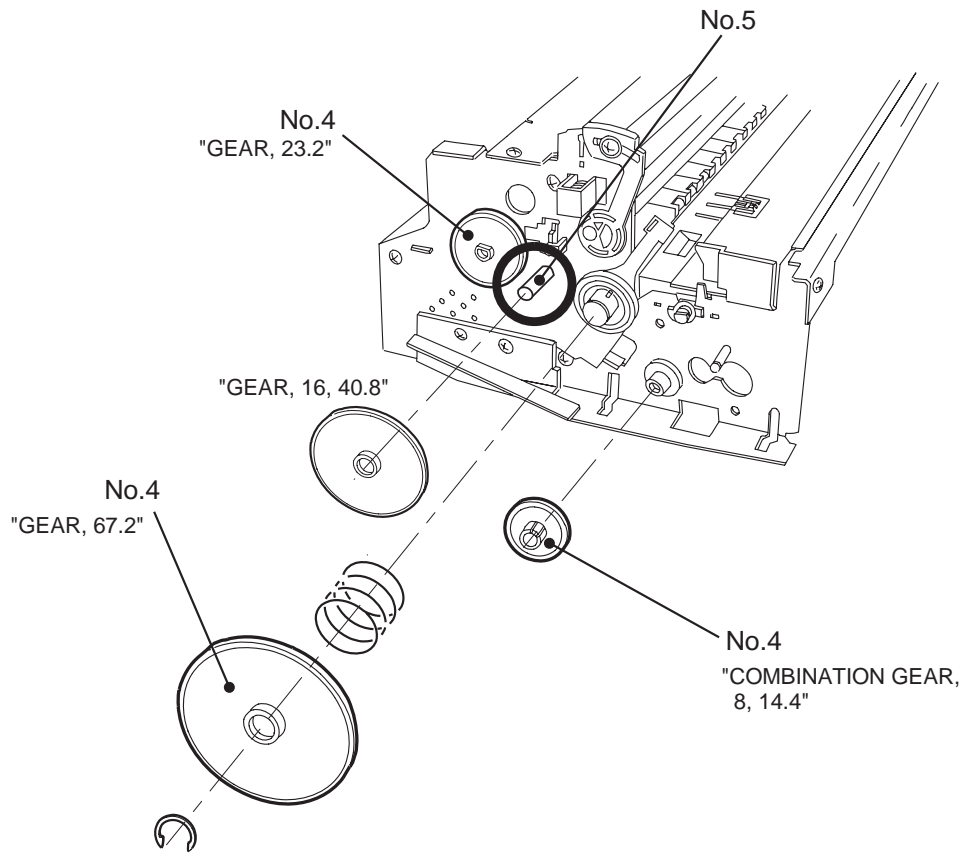

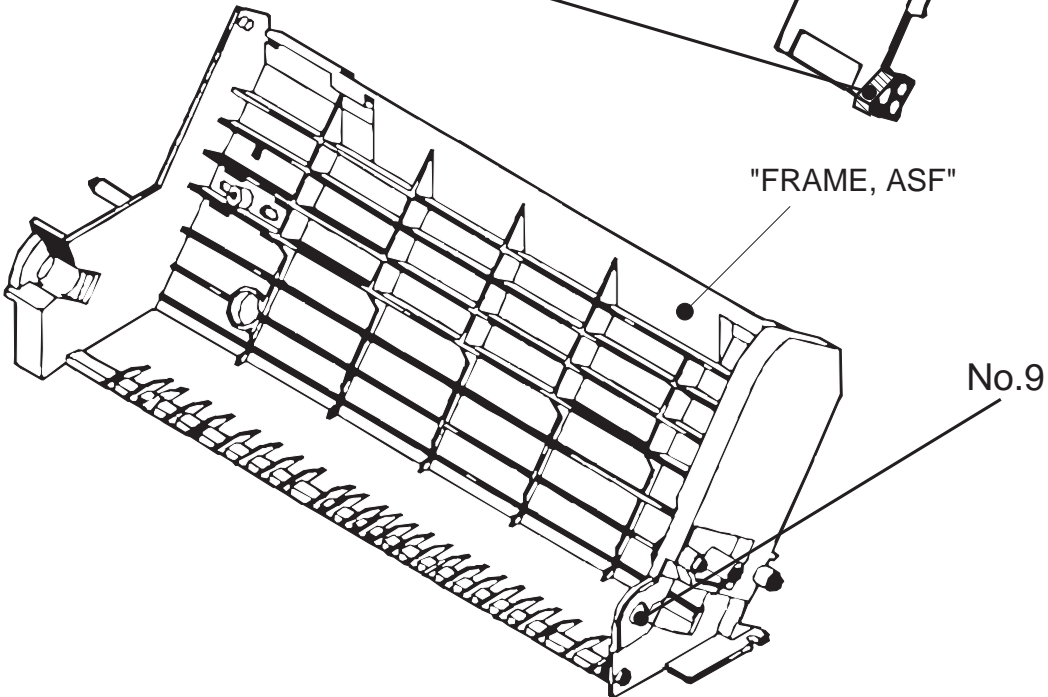
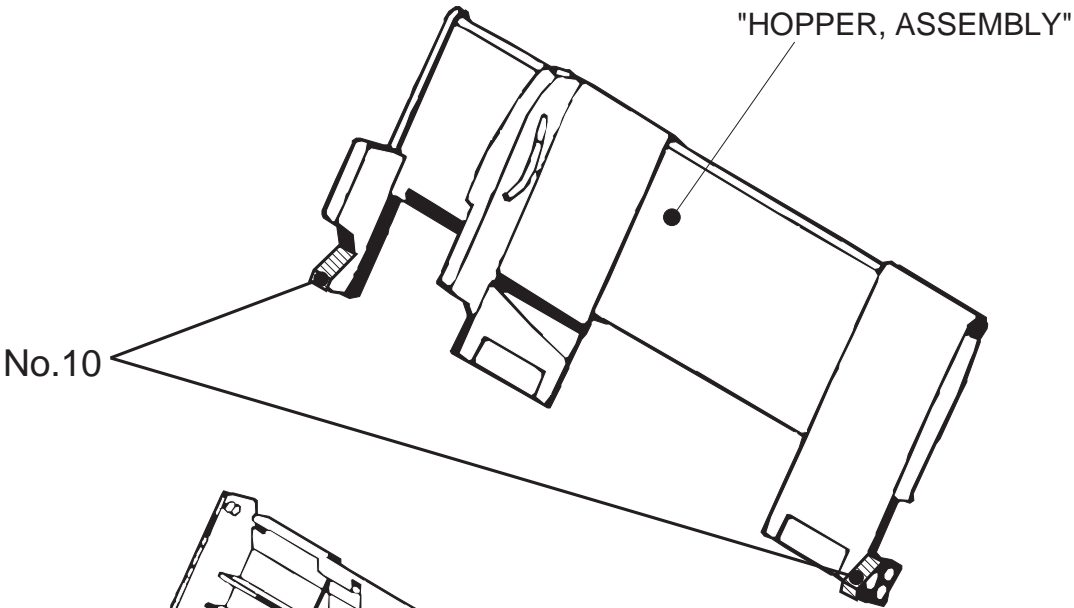
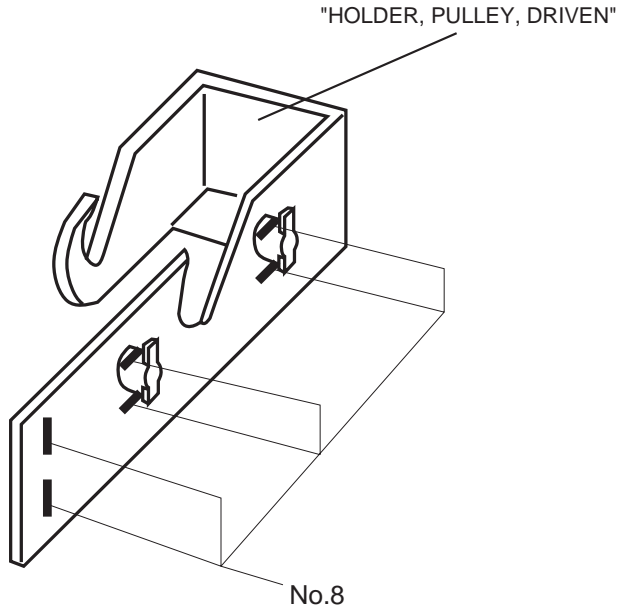

Appendix

A.1 Connector Summary	A-1
A.2 Connector Summary	A-2
A.3 EEPROM Address Map	A-4
A.4 Circuit Board Component Layouts	A-8
A.5 Exploded Diagrams.....	A-13
A.6 Circuit Diagrams	A-18

A.1 Connector Summary

Stylus Color 400 has the following primary component units;

- Main Board(C206 Main)
- Power Supply Board (C206 PSB/PSE)
- Printer Mechanism

Figure A-1 below illustrates how these component units are connected.

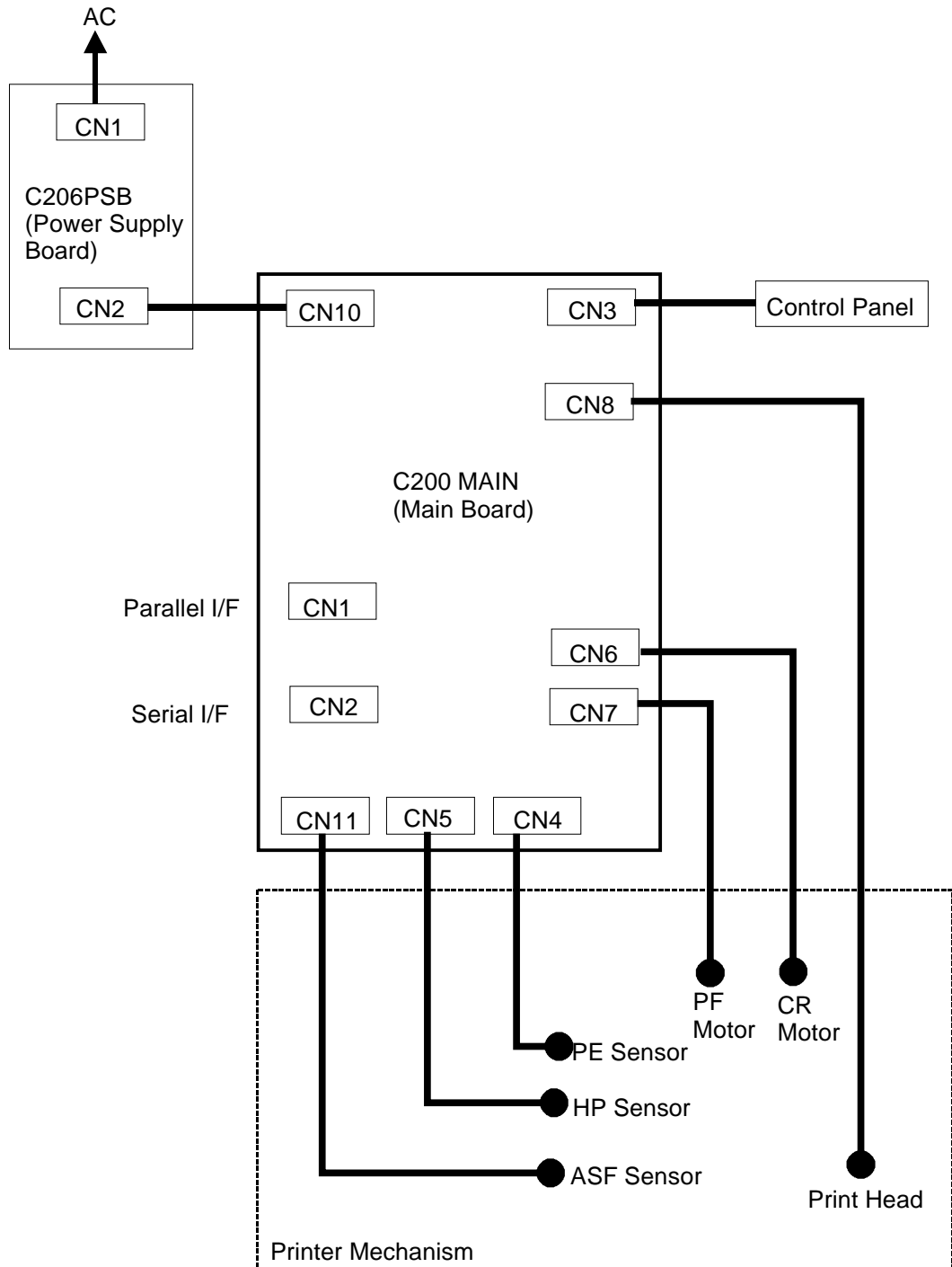

Figure A-1. Cable Connection

A.2 Connector Summary

Following tables show connector pin assignment of the C200 main board.

Table A-1. Connector summary of the C206 Main board

Connector	Function	Table to refer
CN1	Parallel I/F connector	Chapter1/Table 1-10
CN2	Serial I/F connector	Chapter1
CN3	Control panel	Table A-2
CN4	PE sensor	Table A-3
CN5	HP sensor	Table A-4
CN6	CR motor	Table A-5
CN7	PF motor	Table A-6
CN8	Print head	Table A-7
CN10	Power supply board (C206 PSB)	Table A-8
CN11	ASF sensor	Table A-9

Table A-2. Connector CN3

Pin	Signal Name	I/O	Function
1	LED0	Out	LED drive signal (0)
2	GND	---	Ground
3	LED1	Out	LED drive signal (1)
4	GND	---	Ground
5	LED2	Out	LED drive signal (2)
6	+5V	---	Logic power supply
7	+5V	---	Logic power supply
8	LED4	Out	LED drive signal (4)
9	SW1	In	Panel switch input (1)
10	PSC	In	Power on/off switch
11	SW0	In	Panel switch on/off (0)
12	SW2	In	Panel switch on/off (2)

Table A-3. Connector CN4

Pin	Signal Name	I/O	Function
1	PE	In	Sensor detect signal
2	GND	---	Ground
3	PEV	---	Sensor power supply(+5V)

Table A-4. Connector CN5

Pin	Signal Name	I/O	Function
1	HP	In	Sensor detect signal
2	GND	---	Ground
3	HPV	---	Sensor power supply(+5V)

Table A-5. Connector CN6

Pin	Signal Name	I/O	Function
1	CRA	Out	Phase drive signal(A)
2	CR-A	Out	Phase drive signal (-A)
3	CRB	Out	Phase drive signal (B)
4	CR-B	Out	Phase drive signal(-B)

Table A-6. Connector CN7

Pin	Signal Name	I/O	Function
1	PFA	Out	Phase drive signal (A)
2	PF-A	Out	Phase drive signal (-A)
3	PFB	Out	Phase drive signal (B)
4	PF-B	Out	Phase drive signal(-B)

Table A-7. Connector CN8

Pin	Signal Name	I/O	Function
1	BCO	In	Black ink cartridge detect signal
2	CCO	In	Color ink cartridge detect signal
3	THM	In	Thermistor detect signal
4	GND	---	Ground
5	LAT	Out	Head data latch pulse output
6	GND	---	Ground
7	SI3	Out	Head data output (3)
8	GND	---	Ground
9	SI2	Out	Head data output (2)
10	GND	---	Ground
11	CLK	Out	Head data output (1)
12	GND	---	Ground
13	CLK	Out	Clock pulse for head data transfer
14	GND	---	Ground
15	NCHG	Out	Head all on pulse output
16	GND	---	Ground
17	VDD	---	Logic power supply (+5V)
18	GND2	---	Ground
19	GND2	---	Ground
20	GND2	---	Ground
21	COM	---	Head drive power supply
22	COM	---	Head drive power supply
23	COM	---	Head drive power supply
24	VHV	---	Head drive voltage control signal
25	VHV	---	Head drive voltage control signal

Table A-8. Connector CN10

Pin	Signal Name	I/O	Function
1	+42V	---	Mechanism drive power supply
2	+42V	---	Mechanism drive power supply
3	GND	---	Ground
4	GND	---	Ground
5	PSC	Out	Power supply switch output signal
6	GND	----	Ground
7	GND	---	Ground
8	+5V	---	Logic power supply

Table A-9. Connector CN11

Pin	Signal Name	I/O	Function
1	ASF	In	Sensor detect signal
2	GND	---	Ground
3	ASFV	---	Sensor power supply (+5V)

A.3 EEPROM Address Map

Address	Explanation	Setting	QPIT Settings	Factory Settings
00H	Password 0		54H	-
01H			0FH	-
02H	Market	0:Word 1:Japan 2:Custom(MJ-)** 3:Custom(Stylus Color)** 4:Custom (other name)**	00H	(*1)
03H	1st dot adjustment	-40 ≤ n ≤ 40 (by 1/1440 inch)	00H	(*1)
04H	Bi-D adjustment data	-36 ≤ n ≤ 36 (by 1/1440 inch)	00H	(*1)
05H	Uni-D adjustment	-36 ≤ n ≤ 36 (by 1/1440 inch)	00H	(*1)
06H	Reserved		00H	-
07H	Reserved		00H	-
08H	Carriage speed adjustment data	-4 ≤ n ≤ 4 (by G.A timer unit)	00H	(*1)
09H	Reserved		00H	-
0AH	Head actuator rank ID for VhN		12H	(*1)
0BH	Head actuator rank ID for Twhs		01H	(*1)
0CH	Reserved		00H	-
0DH	Reserved		00H	-
0EH	Reserved		00H	-
0FH	Reserved		00H	-
10H	Password 1		5AH	-
11H			0FH	-
12H	Custom EEPROM sub number		00H	00H
13H			00H	00H
14H			00H	00H
15H			00H	00H
16H	Reserved		00H	-
17H	Reserved		00H	-
18H	CPSI password		00H	00H
19H			00H	00H
1AH			00H	00H
1BH			00H	00H
1CH	CPSI flags	bit7:CPSI license 0:Disable 1:Enable bit6:CPSI Font license 0:Disable 1:Enable	00H	00H
1DH	Reserved		00H	-
1EH	Reserved		00H	-
1FH	EEPROM Revision		42H	-
20H	Password 2		5AH	-
21H			0FH	-
22H	Interface selection	0:Auto 1:Parallel 2:Serial	00H	00H*2

Note) ** change model name of IEEE1284 device ID.

*1 Adjusted at factory.

*2 Initialized after performed panel initialization of EEPROM.

Address	Explanation	Setting	QPIT settings	Factory settings
23H	Interface wait time	0 to 255 (by second)	0AH	0AH
24H	Parallel I/F speed	0:High speed 1:Normal	00H	00H
25H	Reserved		00H	-
26H	Reserved		00H	-
27H	Print direction control	0:Bi-D 1:Uni-D 2:Auto	02H	02H
28H	CG table	0:PC437 1:PC850	00H	(*1)
29H	Reserved		00H	-
2AH	Auto LF/Network I/F mode	bit1:Network I/F mode (0=off, 1=on) bit0:Auto line feed (0=off, 1=on)	00H	00H
2BH	Panel mask function	bit5:Extended settings bit2:Cleaning bit1:Replace I/C bit0:Load/Eject	00H	00H
2CH	Reserved		00H	-
2DH	Reserved		00H	-
2EH	Reserved		00H	-
2FH	Reserved		00H	-
30H	Password 3		5AH	-
31H			0FH	-
32H	Reserved		00H	-
33H	Reserved		00H	-
34H	Top margin	42 to 44X360 (by 1/360 inch)	78H	78H
35H			00H	00H
36H	Reserved		00H	-
37H	Reserved		00H	-
38H	Reserved		00H	-
39H	Reserved		00H	-
3AH	Reserved		00H	-
3BH	Reserved		00H	-
3CH	Reserved		00H	-
3DH	Reserved		00H	-
3EH	CR-phase of Home		00H	00H
3FH	ERROR Number		00H	00H
40H	Password 4		5AH	-
41H			0FH	-
42H	Ink flags	bit7:reserved bit6:black "one time" bit5:color "one time" bit4:Initial fill required bit3:reserved bit2:in cleaning seq. bit1:black CL required bit0:color CL required	00H	10H
43H	Ink flags 2	bit2:YMC cartridge changed and cleaned 0:first cartridge 1:changed bit1:Black cartridge changed and cleaned 0:first cartridge 1:changed bit0:Black cartridge changed and cleaned 0:with YMC cartridge 1:alone	00H	00H

Appendix

Address	Explanation	Settings	QPIT settings	Factory settigs
44H	Ink Counter Cb(total) 1count=100(ng)		00H	00H
45H			00H	00H
46H			00H	00H
47H			00H	00H
48H	Ink counter CY(total) 1count=100(ng)		00H	00H
49H			00H	00H
4AH			00H	00H
4BH			00H	00H
4CH	Ink counter Cy(total) 1count=100(ng)		00H	00H
4DH			00H	00H
4EH			00H	00H
4FH			00H	00H
50H	Password 5		5AH	-
51H			0FH	-
52H	Ink counter Cc(total) 1count=100(ng)		00H	00H
53H			00H	00H
54H			00H	00H
55H			00H	00H
56H	Ink counter Csm(total) 1count=100(ng)		00H	00H
57H			00H	00H
58H			00H	00H
59H			00H	00H
5AH	Ink counter Csc(total) 1count=100(ng)		00H	00H
5BH			00H	00H
5CH			00H	00H
5DH			00H	00H
5EH	Reserved		00H	-
5FH	Reserved		00H	-
60H	Password 6		5AH	-
61H			0FH	-
62H	Ink counter Rb		00H	00H
63H			00H	00H
64H	Ink counter Ry		00H	00H
65H			00H	00H
66H	Ink counter A		00H	00H*2
67H			00H	00H*2
68H	power off time		00H	00H*2
69H			00H	00H*2
6AH	CL time		00H	00H*2
6BH			00H	00H*2
6CH	accumulated printing time	0:0 minute 1:15 minutes 2:30 minutes 3:60 minutes 4:90 minutes 5:120 minutes	00H	00H
6DH			00H	00H
6EH			Reserved	00H
6FH	Reserved		00H	-
70H	Password 7		5AH	-
71H			0FH	-

Address	Explanation	Setting	QPIT settings	Factory settings
72H	customized model name	string of counter strings of model field for Device ID	00H	00H
73H			00H	00H
74H			00H	00H
75H			00H	00H
76H			00H	00H
77H			00H	00H
78H			00H	00H
79H			00H	00H
7AH			00H	00H
7BH			00H	00H
7CH			00H	00H
7DH			00H	00H
7EH			00H	00H
7FH			00H	00H

A.4 Circuit Board Component Layouts

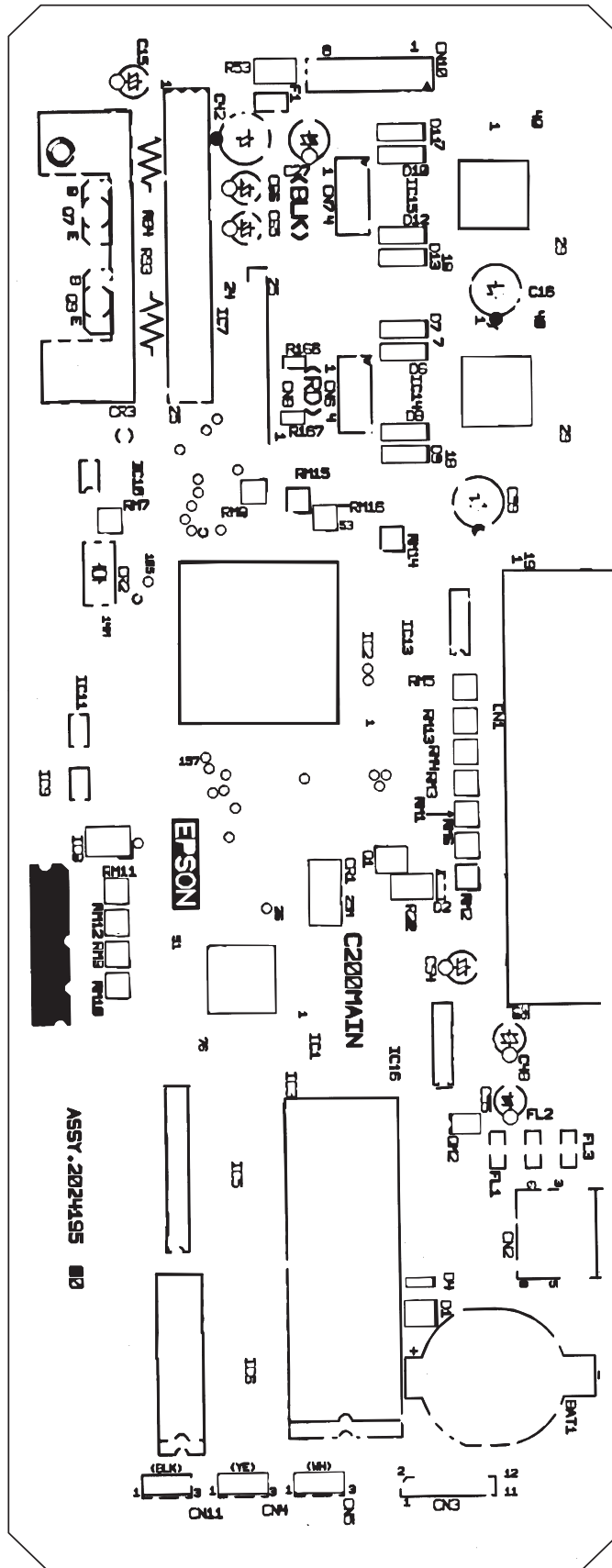

Figure A-2. C200 Main Board Component Layout

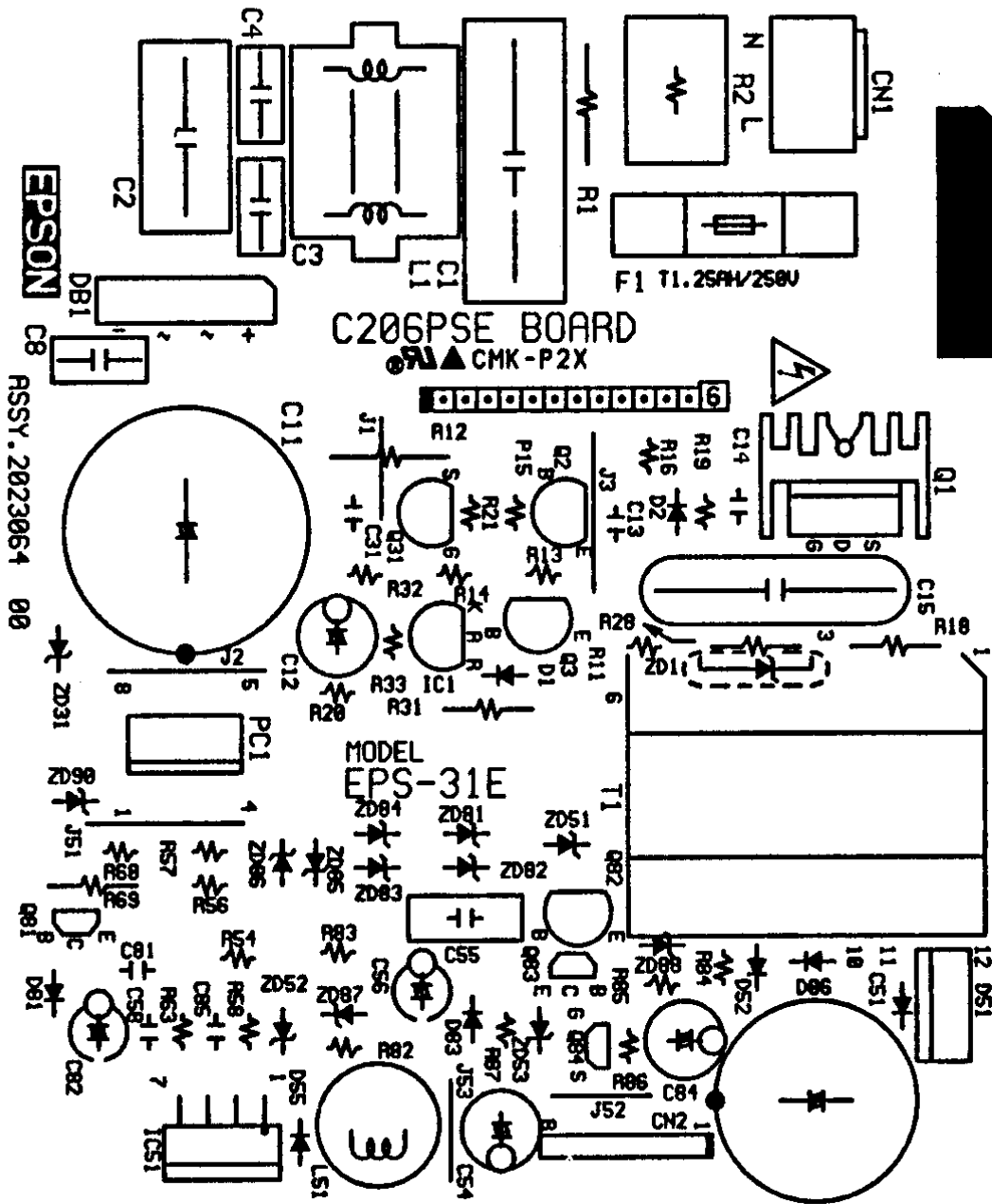

Figure A-4. C206 PSE Board Component Layout

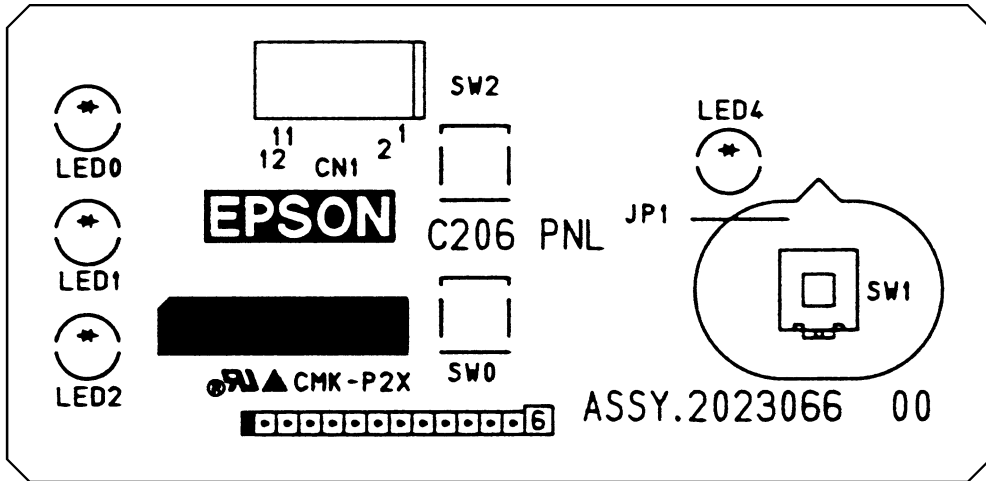
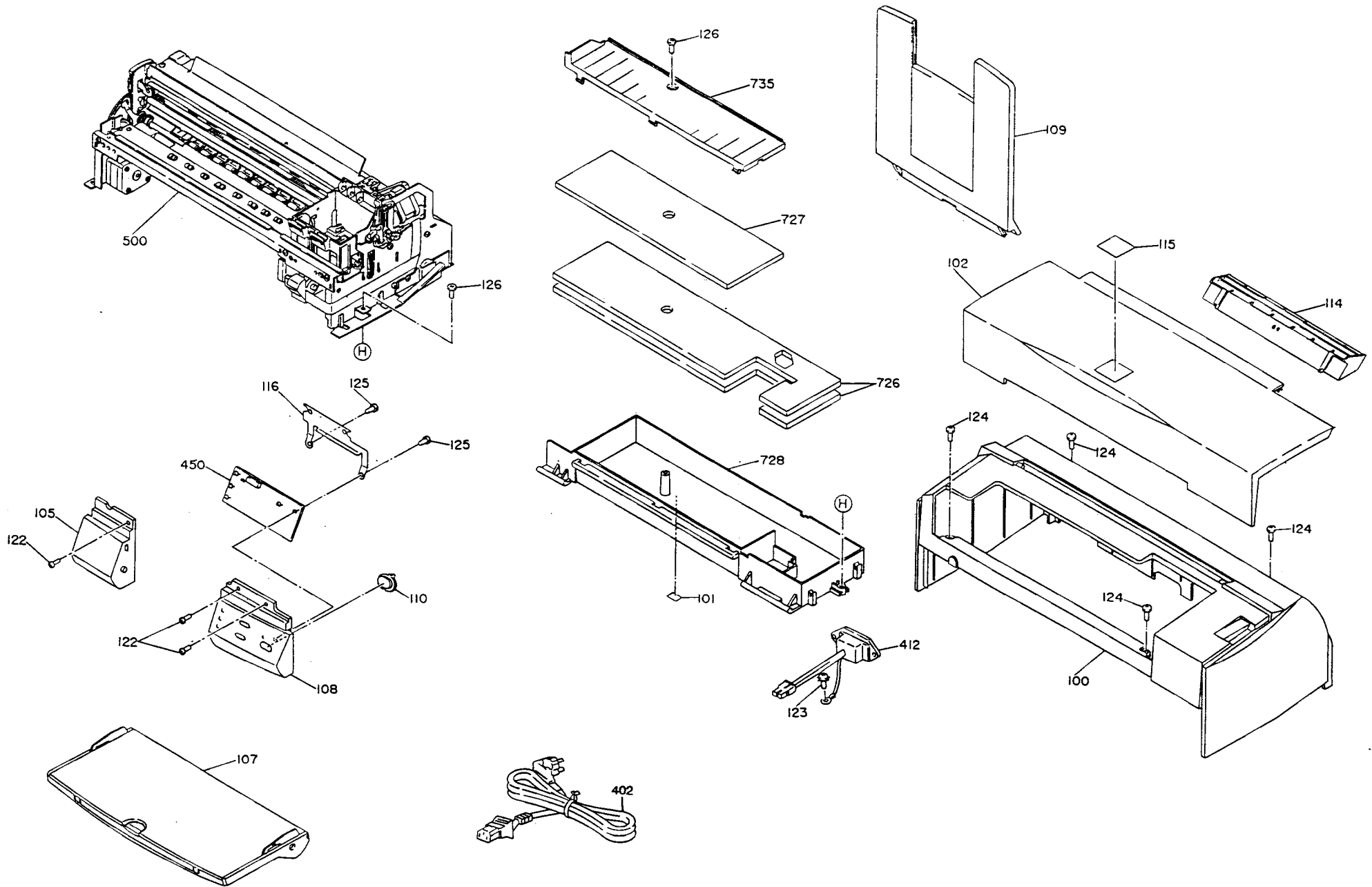
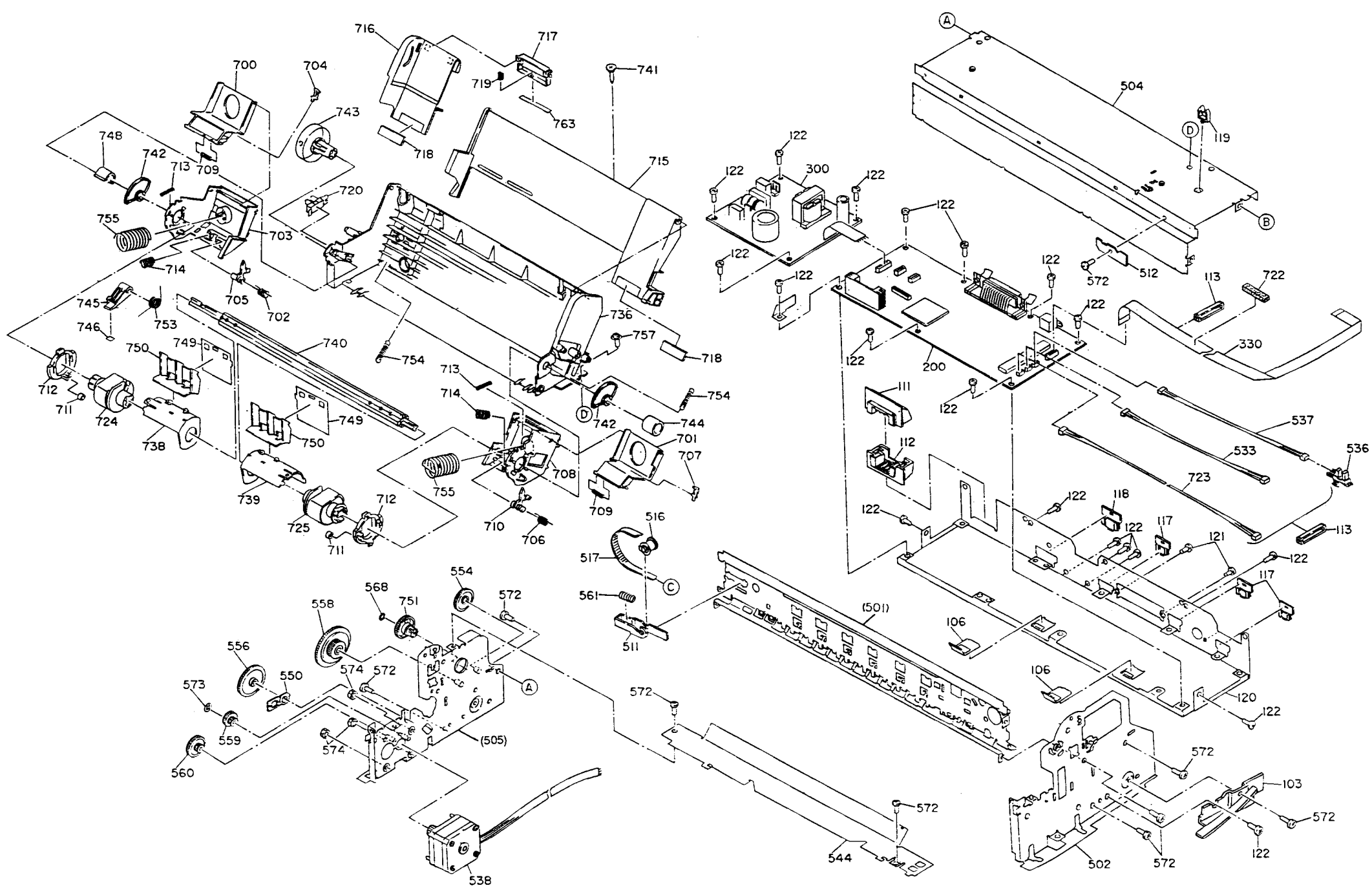

Figure A-5. C206 PNL Component Layout





STYLUS COLOR 600

PARTS PRICE LIST

COUNTRY: USA

Release Date: 5/18/98

EPSON PartFinder Version: 04

EPSON AMERICA, INC.

CONTENTS SUBJECT TO CHANGE WITHOUT NOTICE

Ref. No.	Part No.	Description	Qty	Unit Price	Remarks	Type
100	1030612	HOUSING STYLUS 400	1	22.02		S
101	1033230	FOOT	5	0.25		S
102	1032257	COVER,PRINTER,STYLUS COLOR600	1	14.10		S
103	1030631	HOUSING,SUPPORT,RIGHT	1	2.10		S
104	1030633	HOUSING,SUPPORT LEFT	1	2.10		S
105	1030636		1			
106	1030669	GROUNDING PLATE	2	0.70		S
107	1031311	STACKER ASSEMBLY SC400/600	1	27.78		S
108	1032195	PANEL ASSEMBLY STYLUS 400	1	14.00		S
109	1031312	PAPER SUPPORT ASSEMBLY SC400/600	1	14.00		S
110	1030604	BUTTON,P/S	1	1.10		S
111	1030606	COVER,INLET,UPPER	1	2.10		S
112	1030607	COVER,INLET,LOWER	1	2.10		S
113	1030608	COVER,CABLE	2	0.50		S
114	1033910	ADAPTER,PAPER SUPPORT	1	4.40		S
115	1033121	LOGO PLATE,STYLUS COLOR 600	1	2.10		S
116	1030603		1			
117	1030609	COVER,SHIELD PLATE,M/B,RIGHT	3	0.60		S
118	1030610	COVER,SHIELD PLATE,M/B,LEFT	1	0.70		S
119	1031165	MINI CLAMP	1	0.50		S
120	1032286	SHIELD PLATE,M/B;B	1	11.28		S
121	B010109511	C.P. SCREW (M3X4)	2	0.27		S
122	B300204211	C.B.S.(0) SCREW (M3X6)	23	0.27		S
123	1032538	C.B.(O) SCREW,4X5,F/ZG	1	0.50		S
124	B300204411	C.B.S.SCREW (M3X10)FOR MODEL P82PB	4	0.27		S
125	1005019	C.B.P-TITE SCREW, 3X8,F/ZN	2	0.27		S
126	1012350	C.B.P.-TITE SCREW 3X10,F/ZN	2	0.40		S
450	2023066	BOARD ASSY.,PANEL	1	19.86		S

Ref. No.	Part No.	Description	Qty	Unit Price	Remarks	Type
200	2024195	BOARD ASSY,PHOTO EX	1	225.00	WITHOUT ICI3	S

Ref. No.	Part No.	Description	Qty	Unit Price	Remarks	Type
300	2023062	POWER SPLY,STYLUS400/600/PHOTO	1	132.30		S
300	2023064	POWER SPLY220/240V,STY400/600/PHOTO	1	132.30		S

Ref. No.	Part No.	Description	Qty	Unit Price	Remarks	Type
330	2023343	WIRE HARNESS REF#330	1	6.48		S
400	2002364	POWER CABLE (NON EAI)(VD31303SA-10A	1	24.96		S
401	2006741	POWER CABLE (NON EAI)(BS31303SA-SR-	1	44.51		S
402	2010468	AC CABLE (240V)	1	40.38		S
403	2002365	POWER CABLE VD00303SA-10A 220V	1	42.63		S
403	2008768	POWER CABLE	1	42.63	FOR EHK	S
410	2018054	POWER CABLE ASSY. STANDARD U.S. CAB	1	15.12		S
411	2018055	POWER CABLE ASSY. NON U.S. CABLE	1	15.12		S
412	2018028	HARNESS	1	13.08		S

Ref. No.	Part No.	Description	Qty	Unit Price	Remarks	Type
500	2024052	PRINTER MECH.,STYLUS 400	1	160.00	WITHOUT 515 PRINT HE	S
501	1030341	FRAME TOP	1	7.12		S
502	1030343	FRAME,RIGHT	1	5.28		S
503	1030344	FRAME,FRONT	1	3.80		S
504	1030345	FRAME,BOTTOM	1	8.24		S
505	1031316	FRAME ASSY.,LEFT	1	11.76		S
506	1032426	CARRIAGE ASSY	1	15.42		S
507	1030380	LEVER,ADJUST	1	1.10		S
508	1030381	GROUNDING PLATE,HEAD	1	0.80		S
509	1030382	OIL PAD	1	0.70		S
510	1030387	SLIDER C/R	1	0.70		S
511	1030389	HOLDER,PULLEY DRIVEN	1	1.40		S
512	1032969	SHEET PROTECTION,HEAD	1	1.10		S
513	1030969	SHAFT,ROLLER DRIVEN	6	0.50		S
514	1034351	ROLLER,DRIVEN;B	12	3.10		S
515	F059000	PRINT HEAD,J160-0A0	1	186.98		S
516	1031313	PULLEY ASSY.,DRIVEN	1	3.28		S
517	1030390	TIMING BELT	1	12.32		S
518	1030408	PAPER GUIDE,UPPER	5	1.10		S
519	1030414	PAPER GUIDE,LEFT	1	0.70		S
520	1030417	PAPER GUIDE,REAR	1	7.60		S
521	1032287	PAPER GUIDE,FRONT;B	1	8.80		S
522	1032646	PAPER GUIDE,RIGHT	1	1.10		S
523	1030968	SHAFT,PAPER GUIDE,UPPER	6	0.60		S
524	1030415	STAR WHEEL ASSY.,8	20	0.70		S
525	1032242	HOLDER,STAR WHEEL,RIGHT	1	1.40		S
526	1032243	HOLDER,STAR WHEEL,LEFT	1	1.40		S
527	1032244	ROD SPRING,STAR WHEEL	13	0.40		S
528	1030346	FRAME.,EJ	1	6.48		S
529	1030421	ROLLER ASSY.,EJECT	1	14.00		S
530	1030406	SHAFT,PAPER FEED ROLLER	1	38.34		S
532	2022329	CIRCUIT ASSY.,PE	1	5.44		S
533	2022330	HARNESS,PE	1	3.80		S
534	1030410	LEVER,PE	1	0.70		S
535	1030411	HOLDER,PE	1	0.70		S
536	2021854	DETECTOR,HP	1	6.80		S
537	2022326	HARNESS,HP	1	3.40		S
538	2024054	MOTOR ASSY.,PF	1	47.64		S
539	1031323	MOTOR ASSY.,CR,STYLUS 400	1	53.82		S
540	1030391	SHAFT,CR.GUIDE	1	13.62		S
541	1035882	PUMP ASSY.	1	27.36		S

Ref. No.	Part No.	Description	Qty	Unit Price	Remarks	Type
542	1031315	CAP ASSEMBLY	1	24.30		S
543	1034969	CLEANER,HEAD ASP	1	4.16		S
544	1030347	GUIDE PLATE,CABLE	1	3.80		S
545	1030392	BUSHING,PARALLEL ADJUST	1	1.10		S
546	1030393	BUSHING,PARALLEL ADJUST,RT	1	1.10		S
547	1030394	LEVER,PG	1	1.10		S
548	1030395	LEVER,PG SUPPORT	1	0.60		S
549	1030404	BUSHING 12,LEFT	1	1.10		S
550	1030422	BUSHING, 6	2	0.40		S
551	1030454	LEVER,CHANGE	1	1.80		S
552	1032608	STOPPER,STACKER	2	0.60		S
553	1030353	SPUR GEAR, 11.5	1	0.50		S
554	1030399	SPUR GEAR,23.2	1	0.70		S
555	1030402	SPUR GEAR,67.2	1	5.28		S
556	1030424	SPUR GEAR,36	1	0.70		S
557	1030452	SPUR GEAR,26.4	1	0.70		S
558	1030453	COMBINATION GEAR,16,40.8	1	1.10		S
559	1031001	COMBINATION GEAR,8,14.4	1	3.10		S
560	1031055	COMBINATION GEAR,8,8,21.6	1	1.10		S
561	1030955	COMPRESSION SPRING,19.6	1	0.50		S
562	1030957	COMPRESSION SPRING,5.85	1	0.50		S
563	1030965	COMPRESSION SPRING,0.9	1	0.50		S
564	1030956	TORSION SPRING,117.6	6	0.70		S
565	1030958	TORSION SPRING,0.22	1	0.40		S
566	1032240	TORSION SPRING,63.7	1	0.70		S
567	1030967	WASHER, 12.2X0.5X15	2	0.40		S
568	1030971	WASHER,4.1X0.5X6.5	2	0.25		S
569	1030975	SPACER,C-RING	2	0.25		S
570	B101254590	LEAF SPRING(FOR MODEL P12PB)	1	0.65		S
571	B150300711	RETAINING RING TYPE-E (4)	1	0.27		S
572	B300204211	C.B.S.(0) SCREW (M3X6)	19	0.27		S
573	1023219	BUSHING	1	0.80		S
574	1024505	HEXAGON NUT,NORMAL,M3	3	0.40		S
575	1031164	C-RING	3	0.25		S
576	1032300	SCREW,(P4),3X6,F/ZN	2	0.25		S
577	1032301	SPRING PIN-AW,2X16,F/B	1	0.25		S
580	1034669	POROUS PAD,SLIDER CAP	1	1.10		S
700	1031309	PAD ASSY.,LEFT	1	7.60		S
701	1031308	PAD ASSY.,RIGHT	1	7.60		S
702	1030961	TORSION SPRING,1.22,LEFT	1	0.50		S
703	1030442	HOLDER,EDGE GUIDE,LEFT	1	2.60		S

Ref. No.	Part No.	Description	Qty	Unit Price	Remarks	Type
704	1030449	LEVER,PAD RELEASE,LEFT	1	0.50		S
705	1030434	LEVER,PAPER RETURN,LEFT	1	0.50		S
706	1032245	TORSION SPRING,1.22,RIGHT	1	0.50		S
707	1030450	LEVER,PAD RELEASE,RIGHT	1	0.50		S
708	1030455	HOLDER,EDGE GUIDE,RIGHT	1	2.60		S
709	1030420	ROD SPRING,HOLDER PAD	2	0.50		S
710	1030435	LEVER,PAPER RETURN,RIGHT	1	0.50		S
711	1030436	ROLLER,LD SUPPORT	2	0.25		S
712	1030437	HOLDER,ROLLER LD SUPPORT	2	1.10		S
713	1030962	EXTENSION SPRING,0.36	2	0.25		S
714	1033979		2			
715	1030427	HOPPER	1	7.60		S
716	1030428	EDGE GUIDE	1	3.40		S
717	1030429	SLIDER,EDGE GUIDE	1	1.10		S
718	1030446	CORK	2	1.10		S
719	1030960	COMPRESSION SPRING,3.23	1	0.25		S
720	2021854	DETECTOR,HP	1	6.80		S
721	2023353	CABLE,HEAD	1	12.78		S
722	1033220	SPACER,CABLE HEAD	1	0.70		S
723	2022331	HARNESS,ASF	1	3.52		S
724	1031306	ROLLER ASSY.,LD,LEFT	1	9.92		S
725	1031307	ROLLER ASSY.,LD,RIGHT	1	9.92		S
726	1030372	POROUS PAD,INK EJECT,LARGE	2	9.92		S
727	1030373	POROUS PAD,INK EJECT,SMALL	1	7.60		S
728	1030374	TRAY,POROUS PAD	1	11.28		S
729	1030376	COVER,CARTRIDGE,BLK	1	2.10		S
730	1030377	COVER CARTRIDGE,CLR	1	2.10		S
731	1030378	SEPERATOR,CARTRIDGE,BLK	1	1.10		S
732	1030379	SEPERATOR, CARTRIDGE,CLR	1	1.40		S
733	1030383	FASTENER,HEAD	1	2.10		S
734	1030386	HOLDER,CABLE	1	0.70		S
735	1030419	PAPER GUIDE,,LOWER	1	4.64		S
736	1030426	FRAME,ASF	1	13.20		S
737	1030430	LEVER FASTENER,EDGE GUIDE	2	0.50		S
738	1030438	COVER,ROLLER,LD LEFT	1	1.10		S
739	1030439	COVER,ROLLER,LD RIGHT	1	1.10		S
740	1030440	SHAFT,ROLLER,LD	1	4.40		S
741	1005416	SHAFT, MOUNT, CR	1	0.65		S
742	1030441	LEVER,HOPPER RELEASE	2	0.60		S
743	1030447	WHEEL,DETECT	1	1.40		S
744	1030456	BUSHING,SHAFT FASTENER	1	0.50		S

Ref. No.	Part No.	Description	Qty	Unit Price	Remarks	Type
745	1030951	LEVER,BRAKE	1	0.60		S
746	1030970	PAD,BREAK	1	0.25		S
747	1030973	SPACER,TRAY	1	0.70		S
748	1031178	BUSHING,FASTEN,SHAFT,LEFT	1	0.25		S
749	1032246	SHEET,PAPER FEED	2	0.25		S
750	1032247	HOLDER,SHEET PAPER FED	2	1.10		S
751	1030448	SPUR GEAR,34	1	0.70		S
752	1030954	TORSION SPRING,49	1	0.50		S
753	1030966	TORSION SPRING,41.2	1	0.60		S
754	1030959	EXTENSION SPRING,0.088	2	0.25		S
755	1030964	COMPRESSION SPRING,1.66	2	1.10		S
756	1024130	C.B.P.-TITE SCREW,3X6,F/ZN	1	0.43		S
757	1032300	SCREW,(P4),3X6,F/ZN	1	0.25		S
761	1032719	SHEET CABLE	1	3.10		S
763	1033016	PAD,BREAK,EDGE GUIDE	1	3.10		S
764	1034888	HOLDING SPRING,SPUR GEAR,34	1	0.60		S

Ref. No.	Part No.	Description	Qty	Unit Price	Remarks	Type
01	5006144	STYLUS COLOR 600 CARTON FOR USA	1	5.91		S
01	5006145	STYLUS COLOR 600 CARTON,SPANISH	1	5.91		S
01	5006146	STYLUS COLOR 600 CARTON,EUROPE	1	5.91		S
01	5006147	STYLUS COLOR 600 CARTON, PACIFIC	1	5.91		S
02	5005704	STYLUS CLR400 OUTER CARTON	1	14.80		S
03	5005705	PAD SET,PRINTER	1	8.24		S
04	5005710	PAD,ACCESSORY	1	3.10		S
05	5005889	PAD,STACKER	1	0.25		S
06	X680634010	PLASTIC PROTECTIVE BAG	1	0.27		S

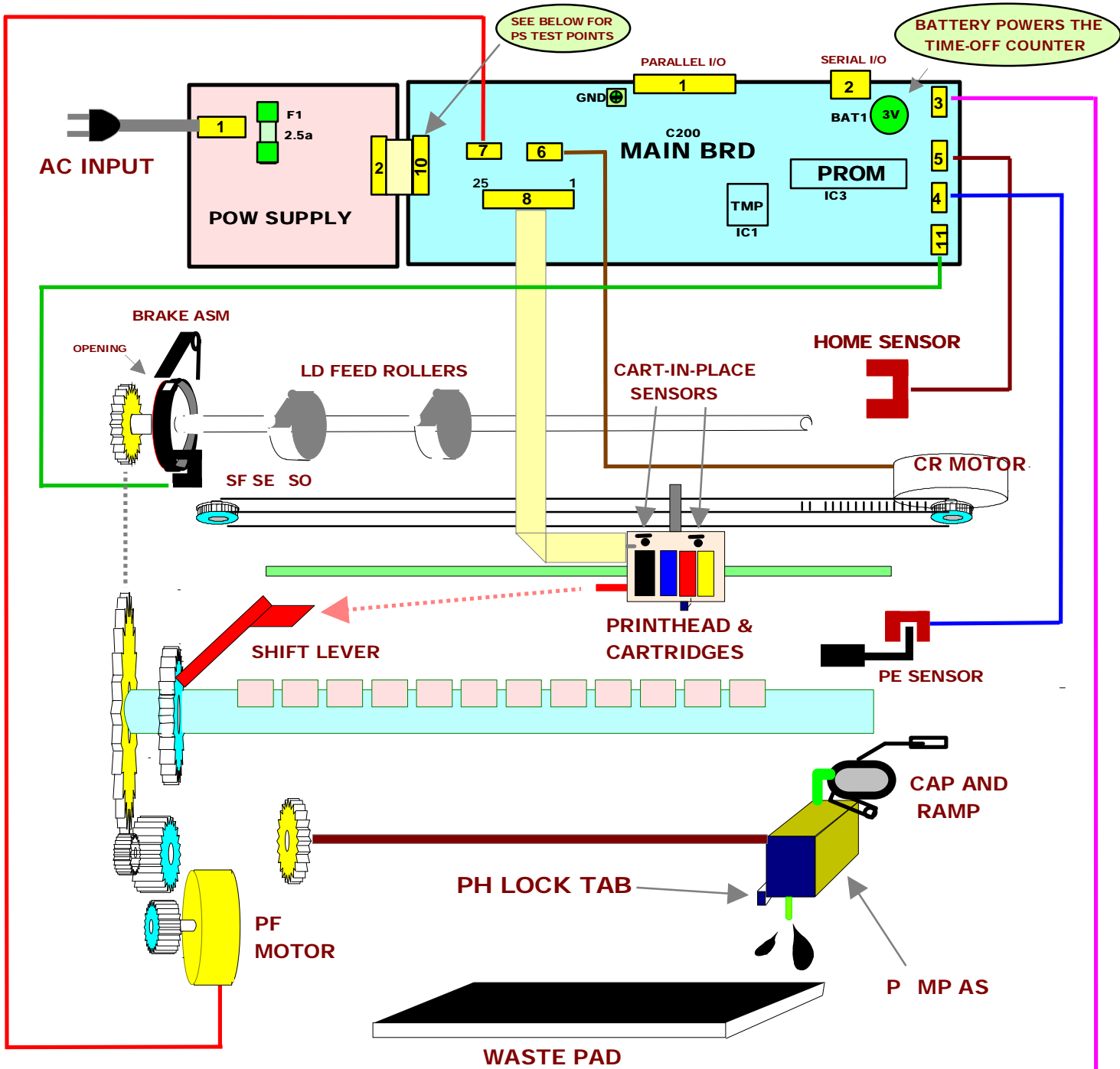

SEE BELOW FOR PS TEST POINTS

BATTERY POWERS THE TIME-OFF COUNTER

POWER SUPPLY TEST POINTS

CN10	
1	+42VDC
2	+42VDC
3	GND
4	GND
5	PSC
6	GND
7	GND
8	+5VDC

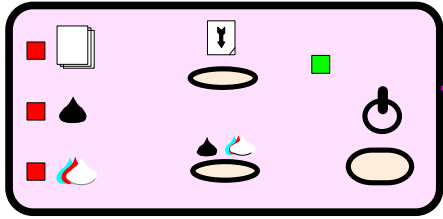

OPERATOR PANEL

EPSON AMERICA, INC.		TRAINING DEPT.	
DRAWING NAME	Stylus Color 600 Functional Diagram	DATE	AUG 98
DRAWN BY	R. Bohn	REV	ISSUE

EPSON OVERSEAS MARKETING LOCATIONS

<p>EPSON AMERICA, Inc.</p> <p>20770 Madrona Avenue, P.O. Box 2842 Torrance, CA 90509-2842 Phone: (800)922-8911 Fax: (310)782-5220</p>	<p>EPSON DEUTCHLAND GmbH</p> <p>Zülpicher Straße 6, 4549 Düsseldorf Germany Phone: (0211)56030 Telex: 8584786</p>
<p>EPSON UK LTD.</p> <p>Campus 100, Maylands Avenue, Hemel Hempstead, Herts, HP2 7TJ U.K. Phone: (+44)01442-61144 Fax: (+44)01442-227227</p>	<p>EPSON FRANCE S.A.</p> <p>68 bis, rue Marjolin 92300, Levallois-Perret France Phone: (1)4087-3737 Telex: 610657</p>
<p>EPSON IBERICA, S.A.</p> <p>Avda. de Roma, 18-26 08290 Cerdanyola del Valles Balcerona, Spain Phone: 582.15.00 Fax: 582.15.55</p>	<p>EPSON ITALIA S.P.A.</p> <p>V. le F. Ili Casiraghi, 427 20099 Sesto S. Giovanni MI Italy Phone: 2-262331 Fax: 2-2440750</p>
<p>EPSON AUSTRALIA PTY. LIMITED</p> <p>1/70 Gibbes Street, Chatswood 2067 NSW Australia Phone: 2-9903-9000 Fax: 2-9903-9177</p>	<p>EPSON SINGAPORE PTE. LTD.</p> <p>No.1 Temasek Avenue #36-00 Millenia Tower Singapore 039192 Phone: (065)3377911 Fax: (065)3341185</p>
<p>EPSON HONG KONG LTD.</p> <p>Rooms 4706-10, 47/F China Resource Bldg. 26 Harbour Road, Wanchai, Hong Kong Phone: 2585-4300 Fax: 2827-7083</p>	<p>EPSON TAIWAN TECHNOLOGY & TRADING LTD.</p> <p>10F, No. 287 Nonking E. Road, Sec. 3, Taipei, Taiwan, R.O.C. Phone: (02)717-7360 Fax: (02)712-9164</p>
<p>EPSON PORTUGAL, S.A.</p> <p>R. do Progresso, 471, 1º Perafita 4460 Matosinhos, Portugal Phone: (02)996 14 02 Fax: (02)996 14 11</p>	
<p>SEIKO EPSON CORPORATION Imaging & Information Products Division</p> <p>80 Harashinden, Hirooka, Shiojiri-Shi, Nagano-Ken 399-07 JAPAN Phone: 0263-52-2552 Fax: 0263-54-4007</p>	

As of September, 1996

EPSON
SEIKO EPSON CORPORATION