

# Pipe Flow Experiments

Group: \_\_\_\_\_ Day: \_\_\_\_\_ Week: \_\_\_\_\_

<b>Library Card Number of Your Group Members</b>

**University of Warwick**

**School of Engineering**

**ES2A7 laboratory Exercises**

## **Section I Theoretical Preparation**

### **1. Introduction**

In this experiment you will investigate the frictional forces inherent in laminar and turbulent pipe flow. By measuring the pressure drop and flow rate through a pipe, an estimate of the coefficient of friction (friction factor) will be obtained. Two different flow situations will be studied, laminar flow and turbulent flow. The experimentally obtained values of the coefficient of friction will then be compared with established results by plotting them on the Moody chart provided.

### **2. Preparation for laboratory class**

It is essential that you have a qualitative understanding of the structure of the flow through a circular pipe. Below is a list of references to pages in the lecture notes of ES2A7 (Technological Science 2) as well as references to appropriate chapters in text books which you should consult before attending today's laboratory. The key topics to recall or to familiarise yourself with are:

- Laminar pipe flow
- Turbulent pipe flow
- Velocity profile
- Volumetric flow rate and mean flow speed
- Coefficient of friction
- Poiseuille flow
- Effect of surface roughness
- Moody Chart

Essential reading for your laboratory course is provided in the computer program, appropriate handouts, the recommended course textbook and your lecture notes. The topics are covered in the following text book in the chapter indicated.

Suggested reading

- White, F. M. 2003, *Fluid Mechanics*, 5th Edition, McGraw-Hill, Chapter 6;
- Roberson J. A., Crowe, C. T., *Engineering Fluid Mechanics*, 6th Edition, John Wiley&Sons, Chapter 10;
- Shames, I. H., *Mechanics of Fluids*, 3rd Edition, McGraw-Hill, Chapter 9;

- Munson B. R., Young D. F., Okiishi, T. H., **Fundamentals of Fluid Mechanics**, 4th Edition, John Wiley&Sons, Chapter 8;
- Tritton, D. J. 1988, **Physical Fluid Dynamics**, 2nd Edition, Oxford Publications, Clarendon Press, Chapter 6.
- Books on fluid mechanics in the library – look for sections on ‘pipe flow’ in any fluid dynamics text book.

### 3. Background

#### 3.1 Turbulent flow and laminar flow, Reynolds number

Figure 1 shows the three regimes of viscous flow. The changeover from laminar flow to turbulent flow is called **transition**. Transition depends upon many effects, e.g., wall roughness or fluctuations in the inlet stream, but the primary parameter is the Reynolds number.

Reynolds number is the ratio of inertial forces ( $\rho U$ ) to viscous forces ( $\mu/L$ ) and is used for determining whether a flow will be laminar or turbulent:

$$Re = \frac{\rho UL}{\mu} \quad (1)$$

Where  $\rho$  is the density of the fluid,  $U$  is the nominal velocity,  $L$  is the characteristic length, and  $\mu$  is the dynamic viscosity of the fluid.

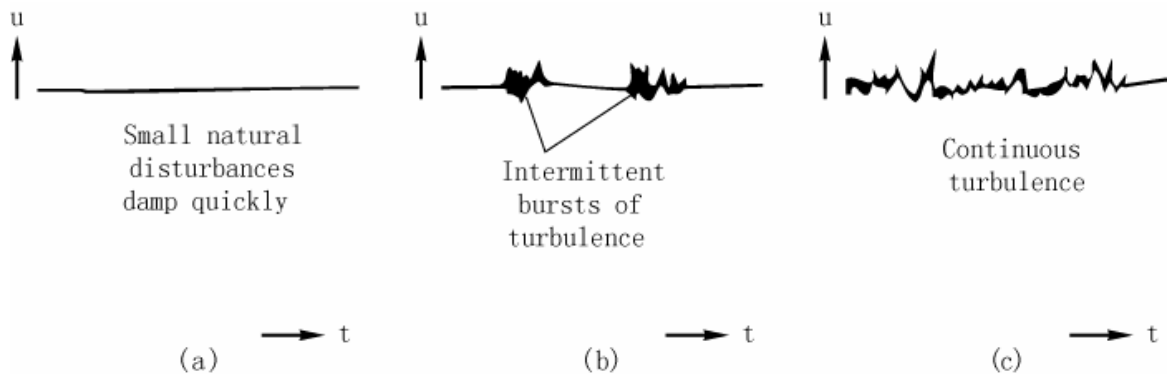

Figure 1. The three regimes of viscous flow: (a) laminar flow at low Re; (b) transition at intermediate Re; (c) turbulent flow at high Re.

Since the velocity profiles of laminar flow and turbulent flow are different (see Figure 2), the nominal velocities used here are the mean velocities of the flows:

$$U = \frac{\nabla}{A \cdot t} = \frac{\nabla}{\pi \left(\frac{d}{2}\right)^2 t} \quad (2)$$

where  $\nabla$  is the measured flowing fluid volume over a period of time  $t$ , and  $A$  is the area of the cross section. Alternatively, given fluid mass  $\mathbb{M}$ :

$$U = \frac{M}{\rho A \cdot t} = \frac{M}{\rho \pi \left(\frac{d}{2}\right)^2 t} \quad (3)$$

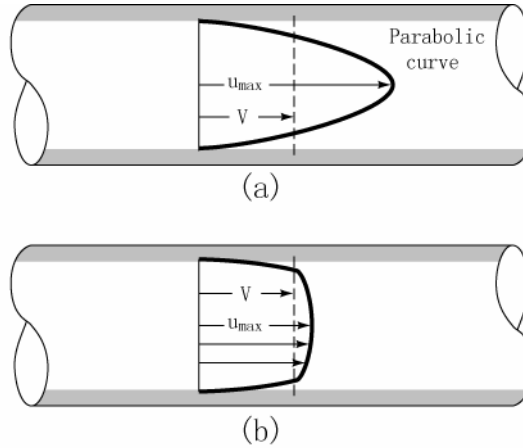

Comparison of laminar and turbulent pipe-flow velocity profiles for the same volume flow:

(a) laminar flow                      (b) turbulent flow

**Figure 2. Velocity Profiles**

### Example 1

The accepted transition Reynolds number for flow in a circular pipe is

$Re_{d,c} = \frac{\rho U d}{\mu} \approx 2,300$ . For flow through a pipe, at what velocity will this occur

at  $20^\circ C$  for:

- (a) oil flow ( $\rho_{oil} = 861 \text{ kg/m}^3$ ,  $\mu_{oil} = 0.01743 \text{ Ns/m}^2$ ) with diameter of  $19 \text{ mm}$ ;
- (b) water flow ( $\rho_{water} = 998 \text{ kg/m}^3$ ,  $\mu_{water} = 0.001003 \text{ Ns/m}^2$ ) with diameter of  $17 \text{ mm}$ ?

### Solution

$$(a) \quad U = \frac{Re_{d,c} \mu_{oil}}{\rho_{oil} d} = \frac{2300 \times 0.01743}{861 \times 0.019} = \underline{\hspace{2cm}}$$

$$(b) \quad U = \frac{Re_{d,c} \mu_{water}}{\rho_{water} d} = \frac{2300 \times 0.001003}{998 \times 0.017} = \underline{\hspace{2cm}}$$

### 3.2 Friction coefficients of pipe flow

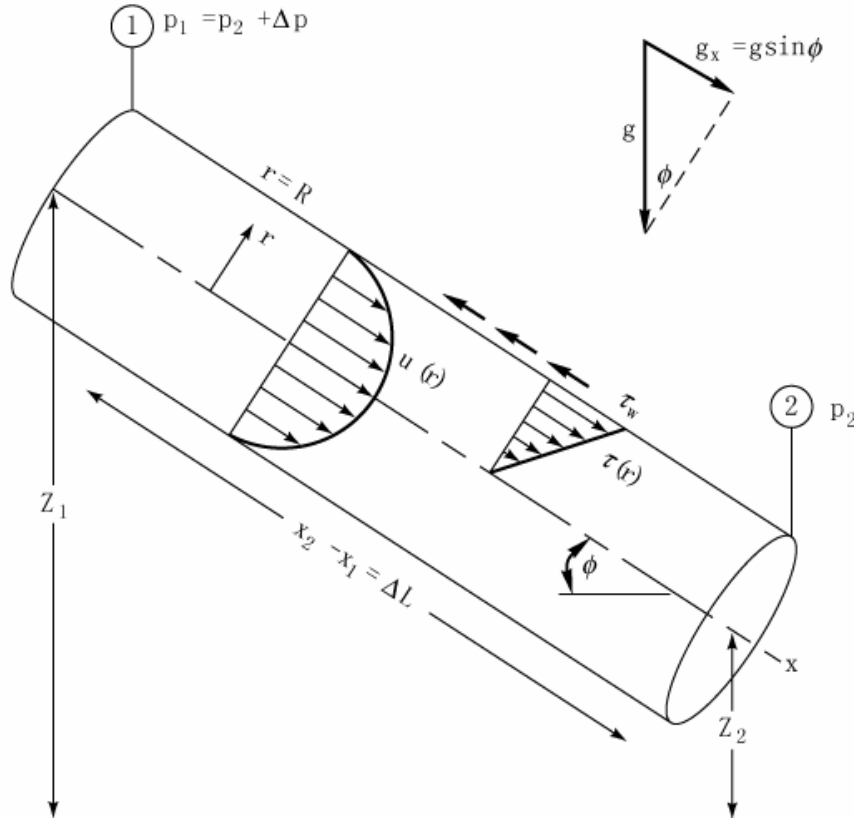

Figure 3. Control volume of a steady, fully developed flow between two sections in an inclined pipe.

Consider fully developed flow through a constant-area pipe between section 1 and 2 in Figure 3. The incompressible steady flow energy equation, including friction loss, would generalise to

$$\left( \frac{p_1}{\rho g} + \frac{U_{m,1}^2}{2g} + z_1 \right) = \left( \frac{p_2}{\rho g} + \frac{U_{m,2}^2}{2g} + z_2 \right) + h_f \quad (4)$$

Where  $h_f$  is the head loss. All terms in equation (4) have dimensions of length  $\{L\}$ . Where  $U_{m,1}$  and  $U_{m,2}$  are the mean flow speeds defined by  $U_{m,1} = Q_1/A$  and  $U_{m,2} = Q_2/A$  (where  $Q_1$ ,  $Q_2$  are the flow rates at position 1, 2 respectively, and  $A$  is the cross-sectional area of the pipe). Since  $U_{m,1} = U_{m,2} = U_m$ , equation (4) reduces to

$$h_f = (z_1 - z_2) + \left( \frac{p_1}{\rho g} - \frac{p_2}{\rho g} \right) = \Delta z + \frac{\Delta p}{\rho g} \quad (5)$$

Where  $\Delta p$  is the pressure drop over length  $L$  of pipe. Applying the momentum relation to the control volume in Figure 3, including forces due to pressure, gravity, and shear gives

$$\Delta p \pi R^2 + \rho g \Delta z \pi R^2 = \tau_w 2\pi RL \quad (6)$$

Where  $R$  is the radius of the pipe, and we have substituted  $\Delta z = L \sin \phi$  from the geometry of Figure 3. We can see that there is a simple relationship between the shear stress,  $\tau_w$  at the wall and the pressure gradient down the pipe. Rearranging the above equation gives

$$\Delta z + \frac{\Delta p}{\rho g} = \frac{4\tau_w L}{\rho g d} \quad (7)$$

Note that this relationship applies equally well to laminar and turbulent flow. By Equations (5) and (7), we find that the head loss is

$$h_f = \frac{4\tau_w L}{\rho g d} \quad (8)$$

Dimensional analysis shows that the head loss can be represented by

$$h_f = f \frac{L U_m^2}{d 2g} \quad (9)$$

The parameter  $f$  is called the **Darcy friction factor**. The friction factor or coefficient of resistance is a non-dimensional measure of the resistance offered by the wall to flow through the pipe. Finally, the Darcy friction factor can be found using Equations (8) and (9)

$$f = \frac{8\tau_w}{\rho U_m^2} \quad (10)$$

For horizontal pipe flow ( $\Delta z = 0$ )

$$\tau_w 2\pi RL = \Delta p \pi R^2 \quad (11)$$

$$\tau_w = \frac{\Delta p R}{2L} \quad (12)$$

From Equation (10) the friction factor  $f$  is defined by

$$f = \frac{4\tau_w}{\frac{1}{2}\rho U_m^2} \quad (13)$$

Thus combining Equations (12) and (13) gives

$$f = \frac{\Delta p}{\frac{1}{2} \rho U_m^2} \frac{d}{L} \quad (14)$$

Alternatively, the **skin friction coefficient** can be defined by

$$C_f = \frac{\tau_w}{\frac{1}{2} \rho U_m^2} \quad (15)$$

### Example 2

An oil with  $\rho = 900 \text{ kg/m}^3$  and  $\mu = 0.18 \text{ Ns/m}^2$  flows through a pipe as shown in Figure 4. The pressures are known at sections 1 and 2, 10m apart. Given the flow rate by  $\nabla = 0.456 \text{ m}^3$  collected in  $t = 1 \text{ min}$ , (a) compute the Reynolds number and tell whether the flow is laminar or turbulent, (b) compute the friction coefficient by Equation (14).

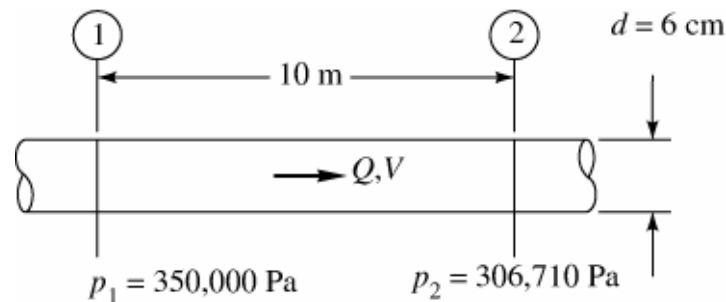

Figure 4

### Solution

$$(a) U = \frac{\nabla}{\pi \left(\frac{d}{2}\right)^2 t} = \frac{0.456}{\pi \left(\frac{0.06}{2}\right)^2 \times 60} = \underline{\hspace{2cm}}$$

$$\text{Re} = \frac{\rho U d}{\mu} = \frac{900 \times \underline{\hspace{1cm}} \times 0.06}{0.18} = \underline{\hspace{2cm}}$$

$$(b) f = \frac{\Delta p}{\frac{1}{2} \rho U^2} \frac{d}{L} = \frac{(350000 - 306710)}{\frac{1}{2} \times 900 \times \underline{\hspace{1cm}}^2} \times \frac{0.06}{10} = \underline{\hspace{2cm}}$$

### 3.3 Effect of Rough Walls, the Moody Chart

Surface roughness also has an effect on friction resistance. It turns out that the effect is negligible for laminar pipe flow, but turbulent flow is strongly affected by roughness. The relations between friction factor, Reynolds number and wall roughness are shown in Moody Chart in Append III.

## Section II Oil Pipe Experiment Calculation

### 1. Theory

Oil pipe: ( $d = 19\text{mm}$ )

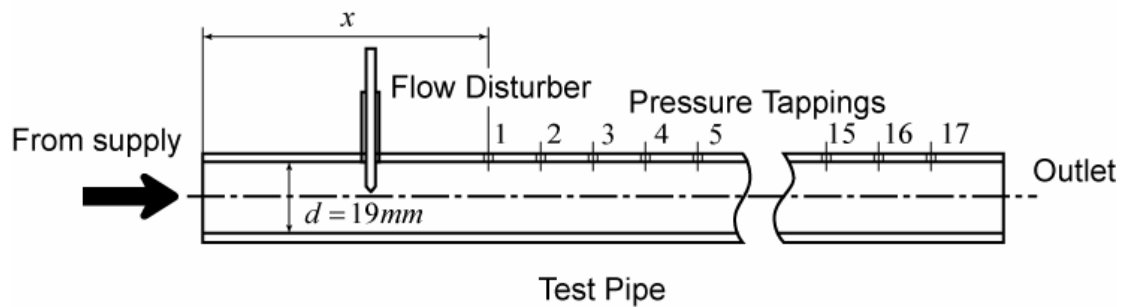

Figure 5. Schematic of oil pipe rig.

Static pressure hole locations:

No.	Inches	mm
1	6	152.4
2	12	304.8
3	18	457.2
4	24	609.6
5	30	726.0
6	36	914.4
7	42	1066.8
8	48	1219.2
9	54	1371.6
10	60	1524.0
11	72	1828.8
12	84	2133.6
13	96	2438.4
14	138	3505.2
15	168	4267.2
16	198	5029.2
17	228	5791.2

Evaluation of  $h_s$

Applying the hydrostatic pressure formula to evaluate pressures at points 1 and 2,



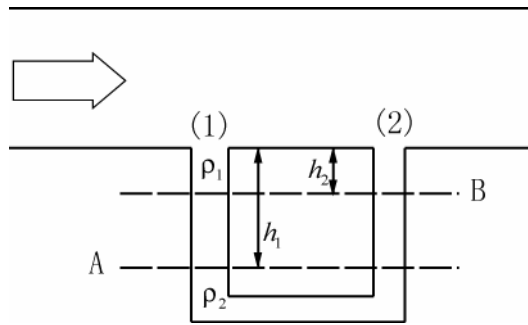

$$p_1 + \rho_1 g h_1 = p_2 + \rho_1 g h_2 + \rho_2 g (h_1 - h_2),$$

$$p_1 - p_2 = -\rho_1 g (h_1 - h_2) + \rho_2 g (h_1 - h_2),$$

$$p_1 - p_2 = (\rho_2 - \rho_1) g (h_1 - h_2),$$

$$p_1 - p_2 = \rho_1 g h_s$$

Where

$$\rho_1 g h_s = (\rho_2 - \rho_1) g (h_1 - h_2),$$

$$h_s = \left( \frac{\rho_2}{\rho_1} - 1 \right) (h_1 - h_2).$$

If  $\rho_1$  is oil (or water) and  $\rho_2$  is mercury (Hg), then

$$p_1 - p_2 = \rho_{oil} g h_s \quad (16)$$

Where

$$h_s = \left( \frac{\rho_{Hg}}{\rho_{oil}} - 1 \right) (h_1 - h_2) \quad (17)$$

### Roughness Values, $\epsilon$ in mm

1. Smooth pipes*	
Drawn brass, copper, aluminum, etc.	0.0025
Glass, Plastic, Perspex, Fiber glass, etc.	0.0025
2. Steel pipes	
New smooth pipes	0.025
Centrifugally applied enamels	0.025
Light rust	0.25
Heavy brush asphalts, enamels and tars	0.5
Water mains with general tuberculations	1.2
3. Concrete pipes	
New, unusually smooth concrete with smooth joints	0.025
Steel forms first class workmanship with smooth joints	0.025
New, or fairly new, smooth concrete and joints	0.1
Steel forms average workmanship smooth joints	0.1
Wood floated or brushed surface in good condition with good joints	0.25
Eroded by sharp material in transit, marks visible from wooden forms	0.5
Precast pipes good surface finish average joints	0.25
4. Other pipes	

\* extruded, cast and pipes formed on mandrels may have imperfections that can increase roughness by a factor of 10.

Sheet metal ducts with smooth joints	0.0025
Galvanized metals normal finish	0.15
Galvanized metals smooth finish	0.025
Cast iron uncoated and coated	0.15
Asbestos cement	0.025
Flexible straight rubber pipe with a smooth bore	0.025
Corrugated plastic pipes <sup>†</sup> (apparent roughness)	3.5
Mature foul sewers	3.0

<sup>†</sup> commercial corrugated plastic pipes in the 40 or 100mm diameter size range have corrugation crest length to depth ratios of about 1.5. Increasing the crest length to depth ratio from 1.5 to 5 may double the friction coefficient.

## 2. Calculation

Two sets of data will be given: one for **LAMINAR** flow and one for **TURBULENT** flow:

1. Mass flow  $\mathbb{M}(kg)$  over time  $t(s)$ , mass flow rate  $\dot{m}$  in  $kg/s$  is to be determined;
2. The pressure at various points along the pipe is given. Plot the manometer reading versus  $x$ . Determine the slope of the plot for the fully developed pipe flow;
3. Noting from the previous page on manometer reading that pressure difference at a point in the pipe is given by equation (derived by Equations (16) and (17))

$$\begin{aligned} p_1 - p_2 &= \rho_{oil} g h_s \\ &= (\rho_{Hg} - \rho_{oil}) g (h_1 - h_2) \end{aligned} \quad (18)$$

Determine  $\Delta p/L$  in  $N/m^3$  from the slope of your graph.

4. Hence determine the value of  $f$  from Equation (14). This is the value corresponding to the given data;
5. Calculate the Reynolds number  $Re_d = \rho U d / \mu$ ;
6. Compare your calculated values of  $f$  with established values by plotting on the Moody chart supplied;
7. Comments on your results.

**Laminar Flow:**

Cross Section Area:  $A = \pi \left( \frac{d}{2} \right)^2 = \pi \left( \frac{0.019}{2} \right)^2 = \text{_____} m^2$

Dynamic viscosity of oil  $\mu = 0.01743 \text{Ns/m}^2$  at a temperature of 300K

Density of oil  $\rho_{oil} = 861 \text{kg/m}^3$  at a temperature of 300K

Density of mercury  $\rho_{Hg} = 13,530 \text{kg/m}^3$  at a temperature of 300K

Note:  $1lb = 0.45359237kg$

**Mass Flow Rate Measurement:**

No.	1	2	3	4	5
Mass: $M(kg)$					
Time: $t(s)$					
Mass Flow Rate: $\dot{m} = \frac{M}{t} (kg/s)$					

Mean Mass Flow Rate:  $\bar{\dot{m}} = \text{_____} kg/s$

Mean Velocity:  $U = \frac{\bar{\dot{m}}}{\rho_{oil}A} = \text{_____} = \text{_____} m/s$

**Manometer Reading**

No.	Location (mm)	Manometer Reading $h(m)$
1	152.4	
2	304.8	
3	457.2	
4	609.6	
5	726.0	
6	914.4	
7	1066.8	
8	1219.2	
9	1371.6	
10	1524.0	

11	1828.8	
12	2133.6	
13	2438.4	
14	3505.2	
15	4267.2	
16	5029.2	
17	5791.2	

Determine Slope from Your Plot:

$$\frac{\Delta h}{L} = \underline{\hspace{10em}}$$

Then

$$\begin{aligned} \frac{\Delta p}{L} &= (\rho_{Hg} - \rho_{oil}) g \frac{\Delta h}{L} = (13,530 - 861) \times 9.81 \times \underline{\hspace{10em}} \\ &= \underline{\hspace{10em}} N/m^3 \end{aligned}$$

Friction Coefficient by Equation (14):

$$\begin{aligned} f &= \frac{\Delta p}{\frac{1}{2} \rho U^2} \frac{d}{L} = \frac{\Delta p}{L} \frac{d}{\frac{1}{2} \rho U^2} \\ &= \underline{\hspace{10em}} \times \frac{0.019}{\frac{1}{2} \times 861 \times \underline{\hspace{10em}}} \\ &= \underline{\hspace{10em}} \end{aligned}$$

Reynolds Number:

$$\begin{aligned} Re_d &= \frac{\rho U d}{\mu} \\ &= \frac{861 \times \underline{\hspace{10em}} \times 0.019}{0.01743} \\ &= \underline{\hspace{10em}} \end{aligned}$$

**Turbulent Flow:**

Cross Section Area:  $A = \pi \left( \frac{d}{2} \right)^2 = \pi \left( \frac{0.019}{2} \right)^2 = \text{_____} m^2$

Dyanmic viscosity of oil  $\mu = 0.01743 \text{Ns/m}^2$  at a temperature of 300K

Density of oil  $\rho_{oil} = 861 \text{kg/m}^3$  at a temperature of 300K

Density of mercury  $\rho_{Hg} = 13,530 \text{kg/m}^3$  at a temperature of 300K

Note:  $1lb = 0.45359237kg$

**Mass Flow Rate Measurement:**

No.	1	2	3	4	5
Mass: $M(kg)$					
Time: $t(s)$					
Mass Flow Rate: $\dot{m} = \frac{M}{t} (kg/s)$					

Mean Mass Flow Rate:  $\bar{m} = \text{_____} kg/s$

Mean Velocity:  $U = \frac{\bar{m}}{\rho_{oil}A} = \text{_____} = \text{_____} m/s$

**Manometer Reading**

No.	Location (mm)	Manometer Reading $h(m)$
1	152.4	
2	304.8	
3	457.2	
4	609.6	
5	726.0	
6	914.4	
7	1066.8	
8	1219.2	
9	1371.6	

10	1524.0	
11	1828.8	
12	2133.6	
13	2438.4	
14	3505.2	
15	4267.2	
16	5029.2	
17	5791.2	

Determine Slope from Your Plot:

$$\frac{\Delta h}{L} = \underline{\hspace{4cm}}$$

Then

$$\begin{aligned} \frac{\Delta p}{L} &= (\rho_{Hg} - \rho_{oil}) g \frac{\Delta h}{L} = (13,530 - 861) \times 9.81 \times \underline{\hspace{2cm}} \\ &= \underline{\hspace{2cm}} N/m^3 \end{aligned}$$

Friction Coefficient by Equation (14):

$$\begin{aligned} f &= \frac{\Delta p}{\frac{1}{2} \rho U^2} \frac{d}{L} = \frac{\Delta p}{L} \frac{d}{\frac{1}{2} \rho U^2} \\ &= \underline{\hspace{2cm}} \times \frac{0.019}{\frac{1}{2} \times 861 \times \underline{\hspace{2cm}}} \\ &= \underline{\hspace{2cm}} \end{aligned}$$

Reynolds Number:

$$\begin{aligned} Re_d &= \frac{\rho U d}{\mu} \\ &= \frac{861 \times \underline{\hspace{2cm}} \times 0.019}{0.01743} \\ &= \underline{\hspace{2cm}} \end{aligned}$$

## Section III Water Pipe Experimental Measurements

Carry out measurements for the water pipe

1. 17mm smooth pipe
2. 15mm rough pipe<sup>1</sup>

1. For each pipe, collect 5 sets of readings. Record your data on the data sheets provided;
2. Work out the Reynolds number, frictional head loss and average fluid velocity.
3. Work out friction coefficients for each pipe;
4. Also, for each pipe produce graphs of  $\log(\Delta p)$  against  $\log(U)$  and also  $\log(f)$  against  $\log(\text{Re})$ ;
5. The gradients and intercepts for each of these straight line graphs should be established;
6. Compare your experimental values of  $f$  with established values by plot (Appendix III);
7. Comment on your results.

**Note:**  $1\text{mmHg} \approx 133.322\text{Pa}$

Find out water properties according to Appendix II.

---

<sup>1</sup> This is the 17mm smooth pipe that has been roughened by a coating of sand grain.



17mm smooth pipe

Cross Section Area:  $A = \pi \left(\frac{d}{2}\right)^2 = \pi \left(\frac{0.017}{2}\right)^2 = \text{_____} m^2$

$L = \text{_____} m$

Reading No.	1	2	3	4	5
Water Temp $T (^{\circ}C)$					
Density $\rho (kg/m^3)$					
Viscosity $\mu (Ns/m^2)$					
Volume $\nabla (m^3)$					
Times $t (s)$					
Volume Flow Rate $Q = \frac{\nabla}{t} (m^3/s)$					
Velocity $U = \frac{Q}{A}$ $(m/s)$					
$\log(U)$					
$\Delta p (kPa)$					
$\log(\Delta p)$					
$Re = \frac{\rho U d}{\mu}$					
$\log(Re)$					
$f = \frac{\Delta p}{\frac{1}{2} \rho U^2} \frac{d}{L}$					
$\log(f)$					

15mm rough pipe

Cross Section Area:  $A = \pi \left(\frac{d}{2}\right)^2 = \pi \left(\frac{0.015}{2}\right)^2 = \text{_____} m^2$

$L = \text{_____} m$

Reading No.	1	2	3	4	5
Water Temp $T (^{\circ}C)$					
Density $\rho (kg/m^3)$					
Viscosity $\mu (Ns/m^2)$					
Volume $\nabla (m^3)$					
Times $t (s)$					
Volume Flow Rate $Q = \frac{\nabla}{t} (m^3/s)$					
Velocity $U = \frac{Q}{A}$ $(m/s)$					
$\log(U)$					
$\Delta p (kPa)$					
$\log(\Delta p)$					
$Re = \frac{\rho U d}{\mu}$					
$\log(Re)$					
$f = \frac{\Delta p}{\frac{1}{2} \rho U^2} \frac{d}{L}$					
$\log(f)$					

## Theory for Pipe Friction Experiment:

Because of friction, when fluid flows along a pipe there must be an energy loss. Firstly in this experiment, we are going to show that the faster the fluid flows, the greater this energy loss.

Fluid can have kinetic energy ( $\frac{1}{2}mv^2$ ) due to its velocity, potential energy ( $mgh$ ) due to its height and also energy associated with its pressure ( $p$ ) times volume. Since water cannot compress if  $10\text{kg/s}$  goes into the pipe,  $10\text{kg/s}$  must come out. It follows that since the pipe we are using has a constant cross-section, the fluid velocity must be constant along the pipe and so the fluid kinetic energy cannot change. Also, since the pipe is horizontal, the fluids potential energy cannot change, and so the energy loss as our fluid flows along the pipe must appear as a pressure loss. First, we are going to produce plot of static pressure drop (or energy per unit volume) against velocity for flow in a smooth pipe. It is advantageous, as will be seen later, to use a '**log-log**' plot. In class we have, or will show, that if two tubes are placed in a pipe as shown below, then

$$p_1 = h_1 g \quad (19)$$

And

$$p_2 = h_2 g \quad (20)$$

We can then write

$$\Delta p = hg \quad (21)$$

where  $\Delta p$  is the pressure drop between the two points in the pipe. Therefore, pressure difference is proportional to the fluid height difference. Since, rather than plot the pressure drop against velocity, we will plot  $\Delta h$  against velocity. This is more convenient, since we will directly measure  $\Delta h$  in our experiment. Our graph should be look like this with, effectively 2 different straight lines. The steeper line is where the flow is laminar and the shallower for turbulent flow. Taking logs has conveniently produced straight lines and so using the equation for a straight line ( $y = mx + c$ ) we can say

$$\log(h) = m \log(U) + \log(c) \quad (22)$$

Which can be rewritten as

$$h = cU^m \quad (23)$$

Your results should show:  $m=1$  for laminar flow;  $m=1.75$  for turbulent flow; and  $m=2$  for fully turbulent flow in a rough pipe.

Darcy showed that the energy loss resulting from fluid flowing through a pipe can be given by this equation:

$$\Delta p = \frac{4fL}{d} \left( \frac{1}{2} \rho U^2 \right) \quad (24)$$

Where  $L$  = length of the pipe being considered,  $d$  = pipe diameter,  $\rho$  = fluid density,  $U$  = mean fluid velocity, and  $f$  = friction factor.

Darcy's equation is useful if we need to choose a suitable pump for a piping system. The bigger the energy loss through our pipe system the 'bigger' the pump we require.

The friction factor  $f$  in Equation (24) is a function of Reynolds number and pipe roughness. We are going to use our experimental data to find the exact form of the function/relationship between  $f$ , Reynolds number ( $Re$ ) and pipe roughness.

Rearranging Darcy's equation, we can write

$$f = \frac{\Delta p}{\frac{L}{d} \left( \frac{1}{2} \rho U^2 \right)} \quad (25)$$

Which since  $\Delta p = \Delta h \rho g$ , can be more conveniently written for our experimental analysis as

$$f = \frac{\Delta h g}{\frac{L}{d} \left( \frac{1}{2} U^2 \right)} \quad (26)$$

If we plot  $\log(f)$  against  $\log(Re)$  we should, again, get straight lines. Note, if we had not taken logs our lines would not have been straight, but curved, which would have been inconvenient.

Again, from the equation for a straight line ( $y = nx + c$ ) we can say  $\log(f) = n \log(Re) + \log c$ , which can be more neatly rearranged to

$$f = c Re^n \quad (27)$$

Where for laminar flow  $c = 16$  and  $n = -1$ , for turbulent flow in the smooth pipe  $c = 0.79$  and  $n = -0.25$ , and for fully turbulent flow in the rough pipe  $f$  depends on roughness only and  $n = 0$ .

## Section IV Requirements For Reports

Your report should consists of

1. Cover sheet provided in handout (with the information on your **group number**, (for example, '**Group 2, Wednesday, Week 16**'), and **library card number** of your group members)
2. A summary of your entire report in not more than two-thirds of a page
3. A brief section on the apparatus and method
4. A brief theory section about laminar/turbulent transition (**Do not just copy the materials in handout, try to find information in Library!**)
5. Sample computations by yourself for one set of measurements
6. Results sections (this should include the readings and the graphs, graphs by hand are not acceptable)
7. Discussion of results including sources of error
8. Conclusions

**This assignment is an individual project. All reports must be written independently. Copying or reproducing the work of other people without acknowledgement will be considered a violation of University Regulations. Any evidence of collusion will be promptly reported to the School of Engineering for action.**

## Appendix I

Answers to the examples:

1. (a)  $2.451\text{m/s}$ ; (b)  $0.136\text{m/s}$ .
2. (a)  $U = 2.69\text{m/s}$ ,  $\text{Re} = 806 < 2300$ , laminar flow; (b)  $f = 0.0798$

# Appendix II

## Physical Properties of Fluids

Table 1 Viscosity and Density of Water at 1 atm

$T, ^\circ C$	$\rho, \text{kg/m}^3$	$\mu, \text{N} \cdot \text{s/m}^2$	$\nu, \text{m}^2/\text{s}$	$T, ^\circ F$	$\rho, \text{slug/ft}^3$	$\mu, \text{lb} \cdot \text{s/ft}^2$	$\nu, \text{ft}^2/\text{s}$
0	1000	1.788 E-3	1.788 E-6	32	1.940	3.73 E-5	1.925 E-5
10	1000	1.307 E-3	1.307 E-6	50	1.940	2.73 E-5	1.407 E-5
20	998	1.003 E-3	1.005 E-6	68	1.937	2.09 E-5	1.082 E-5
30	996	0.799 E-3	0.802 E-6	86	1.932	1.67 E-5	0.864 E-5
40	992	0.657 E-3	0.662 E-6	104	1.925	1.37 E-5	0.713 E-5
50	988	0.548 E-3	0.555 E-6	122	1.917	1.14 E-5	0.597 E-5
60	983	0.467 E-3	0.475 E-6	140	1.908	0.975 E-5	0.511 E-5
70	978	0.405 E-3	0.414 E-6	158	1.897	0.846 E-5	0.446 E-5
80	972	0.355 E-3	0.365 E-6	176	1.886	0.741 E-5	0.393 E-5
90	965	0.316 E-3	0.327 E-6	194	1.873	0.660 E-5	0.352 E-5
100	958	0.283 E-3	0.295 E-6	212	1.859	0.591 E-5	0.318 E-5

Suggested curve fits for water in the range  $0 \leq T \leq 100 ^\circ C$  ;

$$\rho(\text{kg/m}^3) \approx 1000 - 0.0178 |T ^\circ C - 4 ^\circ C|^{1.7} \pm 0.2\%$$

$$\ln \frac{\mu}{\mu_0} \approx -1.704 - 5.306z + 7.003z^2$$

$$z = \frac{273 \text{ K}}{T \text{ K}} \quad \mu_0 = 1.788 \text{ E-3 kg/(m} \cdot \text{s)}$$

Table 2 Viscosity and Density of Air at 1 atm

$T, ^\circ C$	$\rho, \text{kg/m}^3$	$\mu, \text{N} \cdot \text{s/m}^2$	$\nu, \text{m}^2/\text{s}$	$T, ^\circ F$	$\rho, \text{slug/ft}^3$	$\mu, \text{lb} \cdot \text{s/ft}^2$	$\nu, \text{ft}^2/\text{s}$
-40	1.52	1.51 E-5	0.99 E-5	-40	2.94 E-3	3.16 E-7	1.07 E-4
0	1.29	1.71 E-5	1.33 E-5	32	2.51 E-3	3.58 E-7	1.43 E-4
20	1.20	1.80 E-5	1.50 E-5	68	2.34 E-3	3.76 E-7	1.61 E-4
50	1.09	1.95 E-5	1.79 E-5	122	2.12 E-3	4.08 E-7	1.93 E-4
100	0.946	2.17 E-5	2.30 E-5	212	1.84 E-3	4.54 E-7	2.47 E-4
150	0.835	2.38 E-5	2.85 E-5	302	1.62 E-3	4.97 E-7	3.07 E-4
200	0.746	2.57 E-5	3.45 E-5	392	1.45 E-3	5.37 E-7	3.71 E-4
250	0.675	2.75 E-5	4.08 E-5	482	1.31 E-3	5.75 E-7	4.39 E-4
300	0.616	2.93 E-5	4.75 E-5	572	1.20 E-3	6.11 E-7	5.12 E-4
400	0.525	3.25 E-5	6.20 E-5	752	1.02 E-3	6.79 E-7	6.67 E-4
500	0.457	3.55 E-5	7.77 E-5	932	0.89 E-3	7.41 E-7	8.37 E-4

Suggested curve fits for air:

$$\rho = \frac{P}{RT} \quad R_{\text{air}} \approx 287 \text{ J/(kg} \cdot \text{K)}$$

Power law:  $\frac{\mu}{\mu_0} \approx \left(\frac{T}{T_0}\right)^{0.7}$

Sutherland law:  $\frac{\mu}{\mu_0} \approx \left(\frac{T}{T_0}\right)^{3/2} \left(\frac{T_0 + S}{T + S}\right) \quad S_{\text{air}} \approx 110.4 \text{ K}$

with  $T_0 = 273 \text{ K}$ ,  $\mu_0 = 1.71 \text{ E-5 kg/(m} \cdot \text{s)}$ , and  $T$  in kelvins.

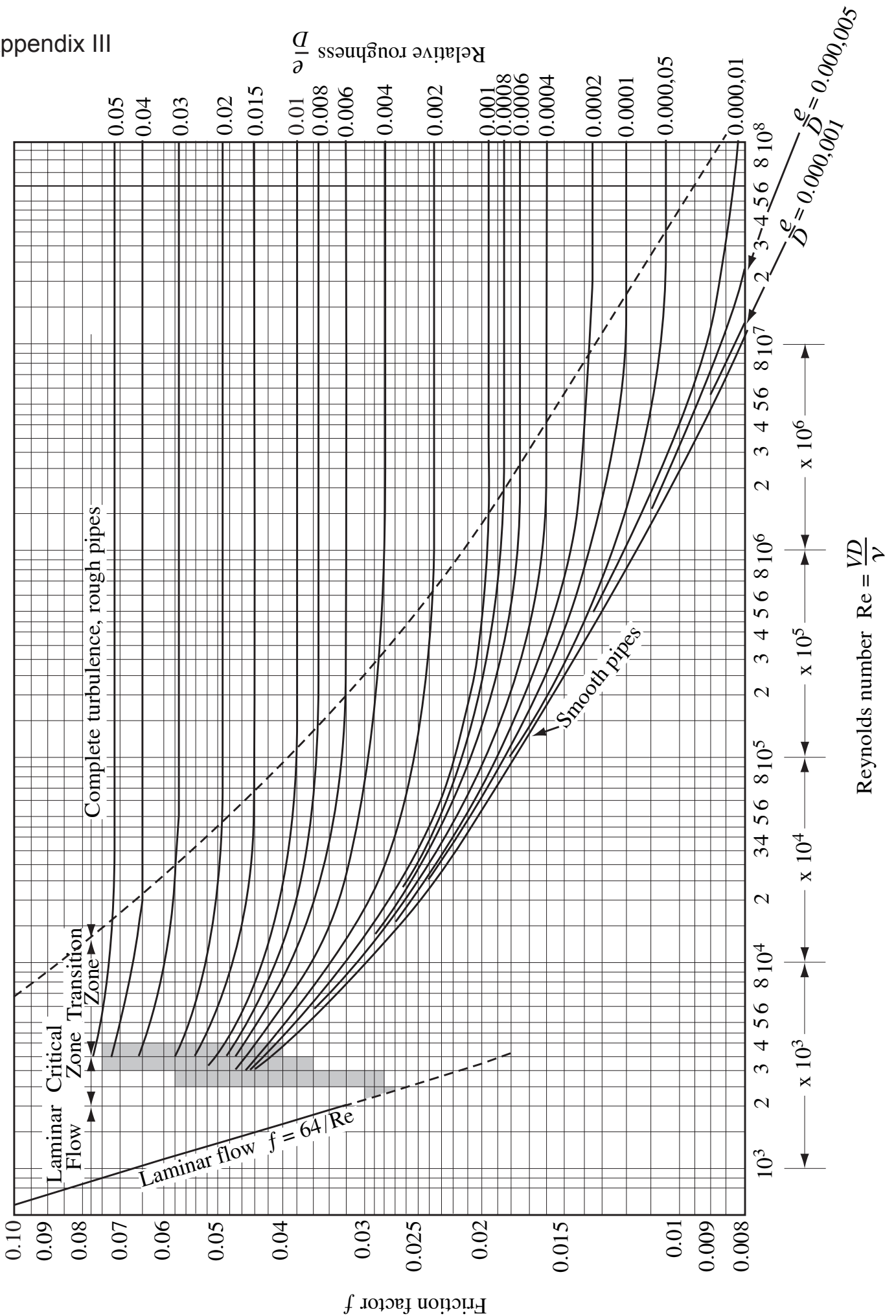

From L. F. Moody, "Friction factors for Pipe Flow," *Trans. A.S.M.E.*, Vol. 66, 1944

The Moody diagram for the Darcy-Weisbach friction factor  $f$ .